

RADIO — ELECTRONICS

SEPTEMBER 1952

LATEST IN TELEVISION • SERVICING • AUDIO

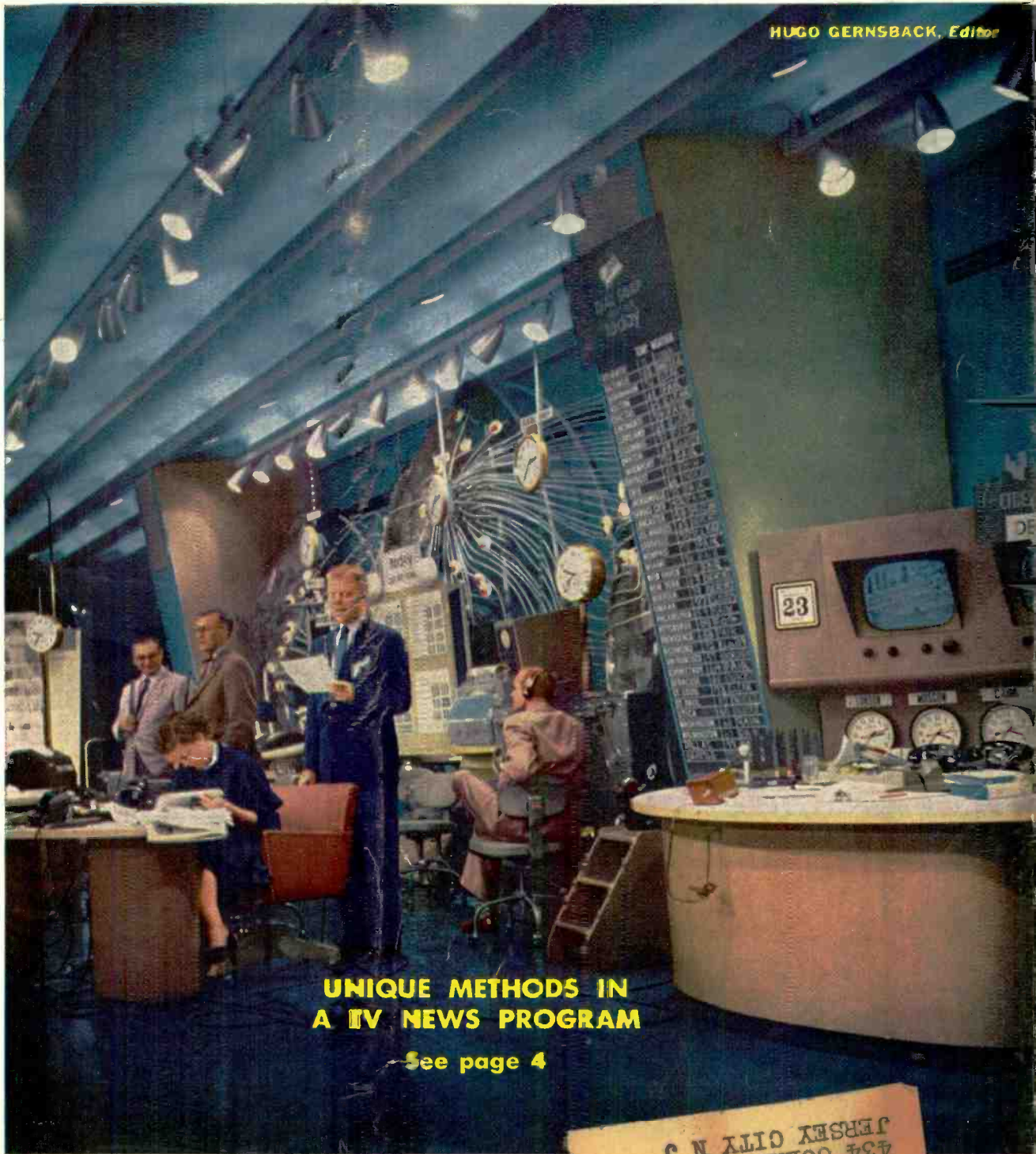

HUGO GERNSBACK, Editor

UNIQUE METHODS IN
A TV NEWS PROGRAM

See page 4

30¢

U. S. and
CANADA

In this issue: Frequency Stabilize
Picture Tube Rejuvenation

EDM O BERGER 11-54
434 OCEAN AVE
JERSEY CITY N J

FREE TELE-MIRROR

... an amazing
one-two offer
with your next purchase
of three Teletrons

two

one

You give *better service* at no extra cost because Teletrons *actually improve* your customer's set performance. That's the bonus Du Mont's acknowledged leadership gives you every time you install a Teletron.

You get the TELE-MIRROR FREE... as an *added bonus* for better service. It's the service tool you've wanted most... needed most... and haven't been able to buy anywhere!

A self-clamping, 8" x 10" BLACK MAGIC mirror, target-lined for accurate picture alignment.

This offer is limited, so act fast! See your Du Mont Jobber today!

ANOTHER

*Teletron**

SERVICE AID

*TRADE MARK



DU MONT

TRAIN

for Security! Good-Paying Jobs!

MAKE THE MONEY YOU'VE ALWAYS DREAMED OF!



LEARN RADIO -TELEVISION

AND ELECTRONICS BY EASY SHOP METHOD TRAINING AT HOME!

**You get
all the parts—even tubes!—**
for this modern Superhetrodyne Receiver. You learn to build it step by step. And you keep it! Get all the facts. Mail coupon now.

Let **NATIONAL SCHOOLS**—a resident-training school for nearly 50 years—train you at home for today's unlimited opportunities in Radio-Television-Electronics. National Schools is one of the largest schools of its kind. It is located in Los Angeles—the center of Radio and TV world! It has four large buildings of modern shops and labs. Its faculty is considered tops in the business.



You learn from lessons prepared by experienced instructors and engineers. Men who are successful Radio and Television technicians. Men who have trained 1000's of men like YOU!

**RADIO-TELEVISION
AND ALLIED ELECTRONICS**



FREE BOOK TELLS YOU HOW!

Page after page—in color—tells you everything you want to know. Mail the coupon. Get this valuable book today. And if you hurry—YOU GET A FREE SAMPLE LESSON, TOO! Shows how easy National Schools Home Training is. Mail the coupon today.

Today's Shortage of Trained Technicians Creates Chance of a Lifetime For You!

Think of it! With guided missiles, radar, and other electronic devices so important to national defense! With big, new developments in TV. With over 90,000,000 home and auto radios, over 12,000,000 TV sets. With more than 3100 radio stations...over 100 TV stations—and more building every day...yes, imagine the great opportunity you have today! YOU are wanted in Radio-Television-Electronics! America's fastest-growing field. High-pay jobs—the kind you've always wanted—are waiting for YOU!

Job Security! Big Money! For YOU! in Today's Expanding Industries!

Trained Radio and Television technicians really make important money these days. Thousands of National Schools graduates—men just like you—are earning good money all over the country. Why not you? And—National Schools graduates get the personal satisfaction of being highly-skilled technicians. Men people respect. Men who enjoy their work—rather than having to drag along in just any old job.

National Schools Has Trained 1000's of Successful Men! Why Not YOU?

In almost every state—and many foreign countries—National Schools graduates are filling big jobs with famous companies. Or running their own successful businesses. What are YOU waiting for? National Schools training is complete training. So when you graduate you can take advantage of today's big opportunities in Radio-Television-Electronics—fast.

You Train At Home—In Your Spare Time

National Schools Shop Method Home Training gives you basic and advanced instruction in all phases of Radio-TV-Electronics. And remember—your training is based on resident school training principles. You learn fast from hundreds of diagrams and pictures. All instructions are written by experienced technicians who work in Radio and TV every day. All instructions have been developed and tested in National Schools' own labs and studios, which are equipped with the latest RCA equipment. No wonder this National Schools course is so up-to-date, practical, interesting. And so easy to learn! And no wonder it is held in such high regard by leaders of American industry! Approved for eligible Veterans.

We Teach You How To Make Welcome Extra Money—While You Learn!

Many National Schools students—men like you—make plenty of extra dollars each week in spare time! Fixing neighbors' radios, appliances—and other ways we teach you. You start learning and earning from the day you enroll. From the very first lesson!

WE SEND YOU LOTS OF PARTS LIKE THIS!

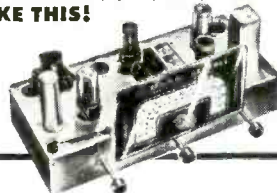

With National Schools Shop Method Home Training, you get basic principles and plenty of practical training. You learn by doing. No wonder you learn so fast! We send you many parts—all of professional, modern quality. You do lots of practical experiments. You advance day by day, step by step. Until you can even build the modern Superhetrodyne Receiver you see above—plus other important testing units. The free book tells you all about it. The free sample lesson shows how easy the training is. Use the coupon. Send today—without fail!

**DON'T PUT
IT OFF!
GET THE
BIG SALARY
YOU HAVE
ALWAYS
WANTED!**



Only National Schools Gives You This Professional Multi-Tester!

You get this amazing, new testing instrument—factory-made and tested—complete—ready to use! Simple to operate. Accurate and dependable. An instrument every Radio-TV man needs. Light enough to carry around—so you can use it at home or on service calls. You'll be proud to own this valuable equipment.

Here are only a few of the Good-Paying Jobs You Can Choose

Radio Station Engineer, District Service Manager, Aircraft Radio Inspector, Own Your Own Repair Shop, Inspector Technician, Service Specialist, Special Government Jobs, Complete TV Service, Sound Truck Operator. Many more! National Schools graduates have secure, good-paying jobs like these! So don't wait—mail the coupon today. Now—while you're thinking about it!

Attention! Men Going into Service Soon!

National Schools' course quickly prepares you for many important jobs in the Armed Services. With National Schools Training you have an opportunity to get into special service classifications—with higher pay and grade—immediately!

FREE SERVICE FOR GRADUATES

National Schools uses its great influence and prestige to help you find your place in the field of your choice. Don't put it off! Start yourself toward a skilled trade! Get the big pay you've always wanted!

NATIONAL SCHOOLS
LOS ANGELES 37, CALIFORNIA • ESTABLISHED 1905
In Canada: 193 E. Hastings St., Vancouver, B. C.

MAIL THIS COUPON TODAY—WITHOUT FAIL!

NATIONAL SCHOOLS, Dept. RG-92
4000 South Figueroa Street
Los Angeles 37, California

Mail in envelope
or paste on
penny post card.

Mail me FREE the book mentioned in this ad. Also a free sample lesson. I understand no salesman will call on me.

NAME _____ AGE _____

ADDRESS _____

CITY _____ ZONE _____ STATE _____

Check here if you were released from the Service less than 4 years ago.

RADIO-ELECTRONICS is published monthly by Radercraft Publications, Inc., at Erie Ave. F to G Streets, Philadelphia 32, Pa. Entered as second class matter September 27, 1948 at the Post Office at Philadelphia, Pa., under the Act of March 3, 1879. Copyright 1952 by Radercraft Publications, Inc. Text and Illustrations must not be reproduced without permission of copyright owners.

SUBSCRIPTION RATES: In U. S. and Canada, in U. S. Possessions, Mexico, South and Central American countries, \$3.50 for one year; \$6.00 for two years; \$8.00 for three years; single copies 30¢. All other foreign countries \$4.50 a year, \$8.00 for two years; \$11.00 for three years.

POSTMASTER: If undeliverable send form 3578 to: RADIO-ELECTRONICS, 25 West Broadway, New York 7, N. Y.

RADIO - ELECTRONICS

Formerly RADIO-CRAFT • Incorporating SHORT WAVE CRAFT • TELEVISION NEWS • RADIO & TELEVISION*

CONTENTS Vol. XXIII, No. 12 SEPTEMBER 1952

Hugo Gernsback
Editor-in-Chief

M. Harvey Gernsback
Editorial Director

Fred Shunaman
Managing Editor

Robert F. Scott
W2PWW, Technical Editor

Mortimer Bernstein
Associate Editor

I. Queen
Editorial Associate

Angie Pascale
Production Manager

Wm. Lyon McLaughlin
Tech. Illustration Director

Sol Ehrlich
Art Director

Lee Robinson
General Manager

John J. Lamson
Sales Manager

G. Aliquo
Circulation Manager

Robert Fallath
Promotion Manager

ON THE COVER

An action photograph (taken during the actual broadcast) of the *Taday* broadcast from the studio in the RCA Exhibition Hall, New York City. Garroway is the middle one of the three standing men. Color original by Avery Slack

Editorial (Page 27)

Status of European Televisionby Hugo Gernsback 27

Television (Pages 28-42)

Picture Tube Testers, Reactivators and Rejuvenators ...by Matthew Mandl 28
Eyestrain from TVby George E. Row 32
The Last Word on Conversion, Part IIby M. H. Gernsback 34
TV DX in September 37
Retrace Blanking in TV Receiversby Gail W. Woodward 38
TV Service ClinicConducted by Matthew Mandl 40
Transmission Line Tunerby Ed Noll and Matt Mandl 42

Servicing—Test Instruments (Pages 43-47)

The Tuning Wand as a Service Toolby Gerald J. Macheak 43
Short Circuitsby Robert F. Scott 44
A Few Simple Cures for Superhet Squealsby Charles E. Cahn 46
Radio Servicing is a Businessby J. W. Essex 47

Audio (Pages 48-53)

Electronics & Music, Part XXVIIby Richard H. Dorf 48
Tape Recording, Part IIby I. Queen 51

Construction (Pages 54-56)

TV Antenna Couplerby Edwin T. Bahr 54
Bandswitching Regenerative Receiverby C. Tierney 56

Electronics (Pages 57-60)

Electronic Multimeters 57
Supersensitive Pilot Relayby Dr. Harry Peach and Edward Spierer 57
Frequency Stabilized Diathermyby Irving Gottlieb 58

Broadcasting & Communications (Pages 61-64)

Unique Methods in a TV News Program (Cover Feature) 61
Mobile Interferenceby Captain William H. Minor, USAF 62

Theory and Engineering (Pages 66-82)

Ultra Q-Teeby Douglas H. Carpenter 66
Cathode Follower Applications Range from Hi-Fi Audio Circuits to VHFby I. Queen 72
Battery Operated Thyatrans 80

New Design (Pages 84-86)

Automatic Voltage Regulation for R.F. High-Voltage Suppliesby Alfred Haas 84
New Tubes 86

Departments

The Radio Manth	10	New Patents ...	99	Technotes	117
Radio Business	16	Try This One ..	105	Miscellany	120
With the		Radio-Electronic		People	123
Technician ..	88	Circuits	108	Communications	127
New Devices ...	94	Question Box ..	113	Book Reviews ..	128



MEMBER Audit Bureau of Circulations

EXECUTIVE, EDITORIAL and ADVERTISING OFFICES: 25 West Broadway, New York 7, N. Y. Telephone REctor 2-8630. Hugo Gernsback, President; M. Harvey Gernsback, Vice-President; G. Aliquo, Secretary.
SUBSCRIPTIONS: Address Correspondence to Radio-Electronics, Subscription Dept. Erie Avenue, F to G Sts., Philadelphia 32, Pa., or 25 West Broadway, New York 7, N. Y. When ordering a change please furnish an address stencil impression from a recent wrapper. Allow one month for change of address.
BRANCH ADVERTISING OFFICES: Chicago: 100 E. Ohio St., Tel. Superior 7-1796. Los Angeles: Ralph W. Harker, 1127 Wilshire Blvd., Tel. Madison 6-1271. San Francisco: Ralph W. Harker, 582 Market St., Tel. GARfield 1-2481. FOREIGN AGENTS: Great Britain: Atlas Publishing and Distributing Co., Ltd., London E.C.4. Australia: McGill's Agency, Melbourne. France: Brentano's, Paris 2^e. Holland: Trietron, Heemstede. Greece: International Book & News Agency, Athens. So. Africa: Central News Agency, Ltd., Johannesburg. Capetown; Durban, Natal. Universal Book Agency, Johannesburg. Middle East: Stelmatsky Middle East Agency, Jerusalem. India: Broadway News Centre, Dadar, Bombay #14. K. L. Kannappa Mudaliar, Madras 2. Pakistan: Paradise Book Stall, Karachi 3. *Trademark registered U.S. Patent Office.

RADIO-ELECTRONICS



Many a well-paid man
is grateful for this FREE
fact-packed booklet, which details

HOW YOU CAN BE SUCCESSFUL IN RADIO-TV-ELECTRONICS

← Send for it today

Every success in Electronics has a story behind it. Sometimes you hear it's "luck." Other times, "contacts." What do the successful men themselves say? *They give credit to training.* In addition, many men on the way up thank the day they sent for a booklet titled "Your Future in the New World of Electronics."

This is the eye-opening survey of the fast-growing world of Electronics. Many eager, ambitious men started their technical careers with a study of this booklet.

Expansion is phenomenal in this dynamic industry. There are over 100,000,000 radios in use! Experts predicted that by 1954 there would be 13,000,000 TV sets. That mark was passed a year ago. Today there are 16,184,000. 109 television stations are now in operation, and the lifting of the freeze will send 1500 to 2500 new stations scrambling for trained personnel—so urgently needed in every phase of electronics. That isn't the whole picture. Consider the tremendous defense orders for electronic installations—consider the fire and police departments, the railroads, the cabs, the aircraft—all using radio. Consider radar. Consider the maritime world with its navigational aids, fathometers, ship-to-shore and ship-to-ship communications. Think of electronic heating, fax and ultra-fax, of electronic medicine, and all the other applications of electronic know-how. Countless positions must be filled—in development, research, design, production, testing, inspection, manufacture, broadcasting, telecasting and servicing. Who can get those positions? You—if you prepare today—if you are alert and have the ambition to advance your knowledge. You—if you take 2 minutes to send for a free copy of "Your Future in the New World of Electronics." This helpful booklet shows you how CREI Home Study leads to greater earnings through the inviting opportunities described above.

CREI, an accredited technical school, does not promise you a "bed-of-roses." You have to translate your willingness to learn into salable technical knowledge—via *study*. Since its founding in 1927, CREI has provided thou-

sands of professional radiomen with technical educations. During World War II, CREI trained thousands for the Armed Services. Leading firms choose CREI courses for group training in electronics at company expense, among them United Air Lines, Canadian Broadcasting Corporation, Trans Canada Airlines, Sears Roebuck & Co., Bendix Products Division, All-American Cables and Radio, Inc., and RCA-Victor Division.

CREI courses are prepared by recognized experts. Assignments are practical and easily-understood. You benefit from the individual supervision of CREI's Staff

of Instructors. This complete training is the reason why CREI graduates find their diplomas keys-to-success in Radio, TV and Electronics. CREI alumni hold top positions in many of America's leading firms.

At your service is the CREI Placement Bureau, which finds positions for students and graduates. Although CREI does not

guarantee jobs, requests for personnel currently exceed supply by far.

Talk to men in the field and check upon CREI's high standing in electronics instruction. Determine for yourself right now that your earnings are going to rise with your knowledge—and that you can get your rightful place in the Age of Electronics. All this CREI can promise you, provided you sincerely want to learn. Fill out the coupon and mail it today. We'll promptly send you your free copy of "Your Future in the New World of Electronics." The rest—your future—is up to you.

CREI resident instruction (day or night) is offered in Washington, D. C. New classes start once a month. Check coupon for residence school catalog. **VETERANS:** If discharged since June 27, 1950—you are eligible for G.I. benefits. For details, place additional check-mark in coupon.

MAIL COUPON FOR FREE BOOKLET

CAPITOL RADIO ENGINEERING INSTITUTE
Dept. 149D, 16th & Park Rd., N.W., Washington 10, D. C.

Send booklet "Your Future in the New World of Electronics" and course outline.
 LHMCK } TV, FM & Advanced AM Servicing Aeronautical Radio Engineering
 FIELD OF } Practical Television Engineering
 GREATEST } Broadcast Radio Engineering (AM, FM, TV)
 INTEREST } Practical Radio Engineering

Name.....

Street.....

City.....Zone.....State.....

Check Residence School Catalog G.I. Information

Telephone Science Shares Its Knowledge

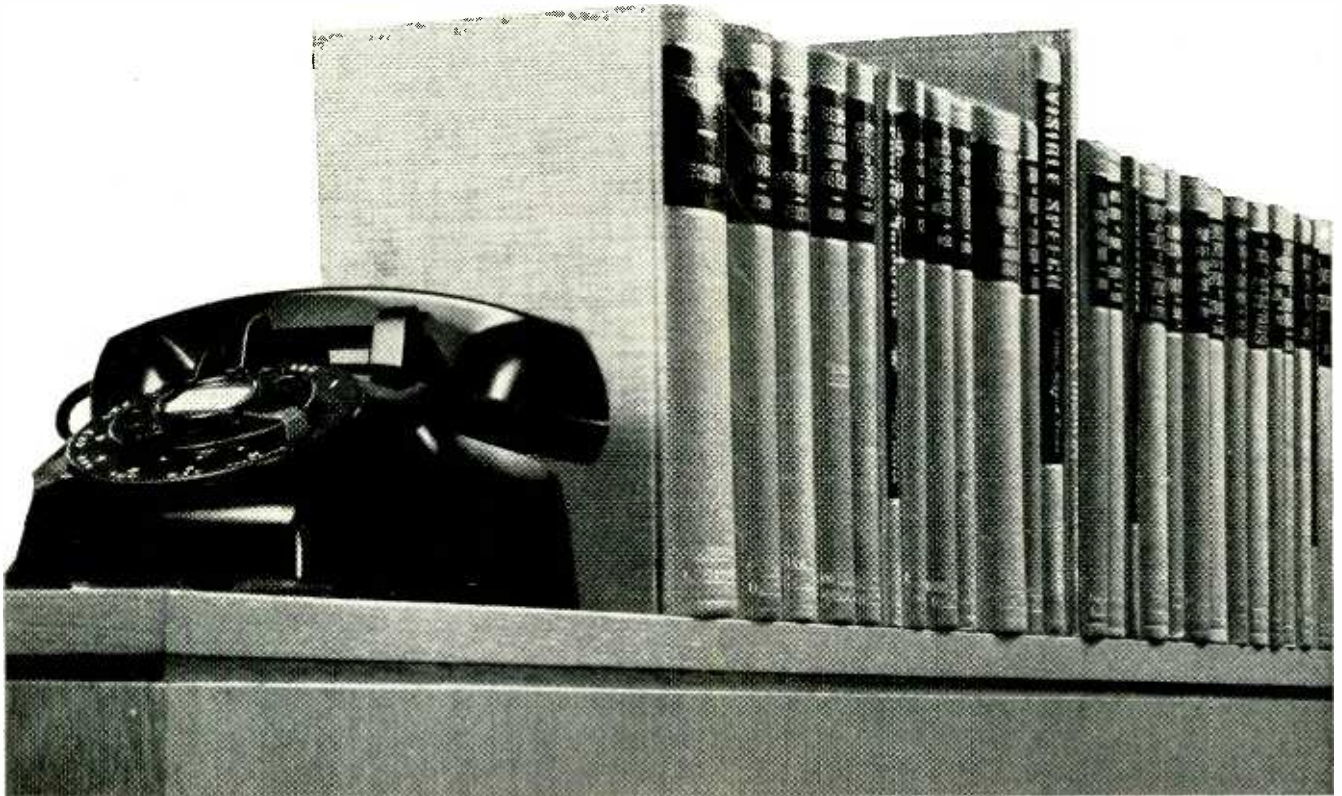

The Bell Telephone Laboratories Series of books is published by D. Van Nostrand Company. Other technical books by Laboratories authors have been published by John Wiley & Sons. Complete list of titles, authors and publishers may be obtained from Publication Dept., Bell Telephone Laboratories, New York 14.

List of Subjects: Speech and hearing, mathematics, transmission and switching circuits, networks and wave filters, quality control, transducers, servomechanisms, quartz crystals, capacitors, visible speech, earth conduction, radar, electron beams, microwaves, waveguides, traveling wave tubes, semiconductors, ferromagnetism.

In their work to improve your telephone service, Bell Laboratories make discoveries in many sciences. Much of this new knowledge is so basic that it contributes naturally to other fields. So Bell scientists and engineers publish their findings in professional magazines, and frequently they write books.

Most of these books are in the *Bell Telephone Laboratories Series*. Since the first volume was brought out in 1926, many of the books have be-

come standards... classics in their fields. Twenty-eight have been published and several more are in the making. They embody the discoveries and experience of one of the world's great research institutions.

Bell scientists and engineers benefit greatly from the published findings of workers elsewhere; in return they make their own knowledge available to scientists and engineers all over the world.



BELL TELEPHONE LABORATORIES

Improving telephone service for America provides challenging opportunities for individual achievement and recognition in scientific and technical fields.

RADIO-ELECTRONICS

NOW... GET EVERYTHING YOU NEED TO LEARN AND MASTER

TELEVISION

RADIO-ELECTRONICS ...AT HOME!

Use REAL commercial-type equipment to get practical experience

Your future deserves and needs every advantage you can give it! That's why you owe it to yourself to find out about one of the most COMPLETE, practical and effective ways now available to prepare AT HOME for America's billion dollar opportunity field of TELEVISION-RADIO-ELECTRONICS. See how you may get and keep the same type of basic training equipment used in one of the nation's finest training laboratories... how you may get real STARTING HELP toward a good job or your own business in Television-Radio-Electronics. Mail the coupon today for complete facts — including 89 ways to earn money in this thrilling, newer field.

D.T.I., ALONE, INCLUDES BOTH MOVIES and HOME LABORATORY
In addition to easy-to-read lessons, you get the use of HOME MOVIES — an outstanding training advantage — plus 16 big shipments of Electronic parts. Perform over 300 fascinating experiments for practical experience. Build and keep real commercial-type test equipment shown at right

Get BOTH of these information packed publications FREE!

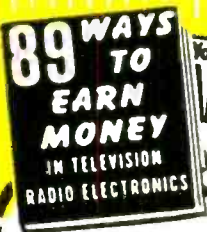

MODERN LABORATORIES

If you prefer, get all your preparation in our new Chicago Training Laboratories—one of the finest of its kind. Ample instructors, modern equipment. Write for details!

MILITARY SERVICE!

If you're subject to military service, the information we have for you should prove very helpful. Mail coupon today.

ACT NOW! MAIL COUPON TODAY!

DE FOREST'S TRAINING, INC., Dept. RE-9-1
2533 N. Ashland Ave., Chicago 14, Ill.

Without obligation, I would like your Opportunity News Bulletin showing "89 Ways to Earn Money in Television-Radio-Electronics"; also, the folder showing how I may prepare to get started in this thrilling field.

Name.....Age.....
Address.....Apt.....
City.....Zone.....State.....



17 INCH TUBE

Here's the REAL THING!
SET UP YOUR OWN HOME LABORATORY

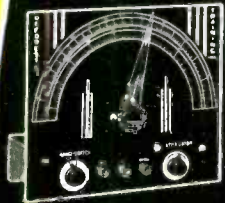

R-F Signal Generator



Oscilloscope

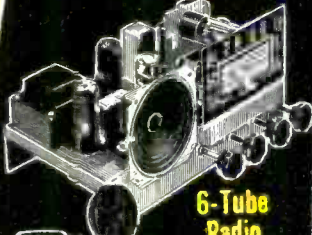

6-Tube Radio
Home Movies

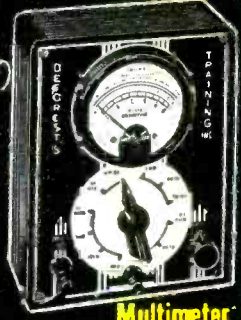

Multimeter

"ONE OF AMERICA'S FOREMOST TELEVISION TRAINING CENTERS"

De FOREST'S TRAINING, INC.
CHICAGO 14, ILLINOIS
A De VRY INSTITUTION

*Long Life—Low Maintenance
No Comebacks with the*

New **300 OHM
TRANSMISSION CABLE**

by BELDEN



To You,
Belden's Golden Anniversary
Means

—product performance that can come only from a "know-how" that has grown through actual service since the inception of Radio.

—an ability to co-operate in pioneering new wires to meet or anticipate industry's growing needs.

In the years that follow

This Belden Program Is—

— TO BE CONTINUED

No. 8230



**COPPER-SHEATHED
20-GAUGE**

STRANDED STEEL WIRE

Brown Polyethylene—Resists Weather and Oxidation

The new Belden Weldohm, 300-ohm Transmission Cable is the greatest advancement in television installation since television began.

Reducing TV lead-in conductor breakage to a minimum is easy. The new Belden Weldohm Cable has overcome the breakage point by 162%, that's 1½ times the strength of pure copper wire.

In actual test, Belden Weldohm Cable will withstand 254% more whipping or severe flexing than the average installation of 300-ohm copper lead-in wire.

There is no difference in the electrical characteristics between an all-copper conductor and the Belden Weldohm copper-coated steel wire. The web is 72 mils of 100% virgin polyethylene.

Replace with Belden Weldohm or make your next new installation with Weldohm and avoid expensive loss of time and labor.

Specify Belden—Weldohm Transmission Cable.

Belden Manufacturing Co., 4623 W. Van Buren St.
Chicago 44, Illinois



Belden
Radio **WIRE**

Which Do You Want?



Better Pay



A Nice Home

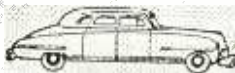

A New Car



Greater Security



Happy Vacations and Travel

Get Your FCC Ticket Then Use Our Amazingly Effective Job-Finding Service To Get a Better Job

Add Technical Training to Your Practical Experience and

Get Your FCC COMMERCIAL RADIO OPERATOR LICENSE

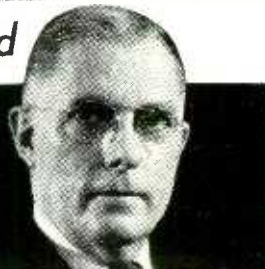

I can train you to pass your FCC License Exams in a minimum of time. If you've had any practical radio experience—amateur, Army, Navy, radio servicing or other, My time-proven plan can help put you, too, on the road to success.

Let me send you FREE the entire story. Just fill out the coupon and mail it. I will send you, free of charge, a copy of "How to pass FCC License Exams," plus a sample FCC-type Exam, and the amazing new booklet, "Money Making FCC License Information." Edw. H. Guilford, Vice-President

in a Minimum of Time

Get this Amazing Booklet FREE

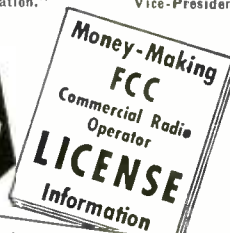

TELLS HOW — WE GUARANTEE

TO TRAIN AND COACH YOU AT HOME IN SPARE TIME UNTIL YOU GET

YOUR FCC LICENSE

If you have had any practical experience—Amateur, Army, Navy, radio repair, or experimenting.

TELLS HOW — Employers Make

JOB OFFERS Like These to Our Graduates Every Month

Letter from Chief Engineer, Broadcast Station, North Carolina, "Need men with radiotelephone 1st class license, no experience necessary. Will learn more than at average station for we are equipped with Diesel Electric power, transmitting and studio equipment."

Telegram from Chief Engineer, Broadcast Station, Wyoming, "Please send latest list available first class operators. Have November 10th opening for two combo men."

Letter from Chief Engineer, Broadcast Station, Texas, "Please send list of latest licensed graduates."

HERE'S PROOF FCC LICENSES ARE OFTEN SECURED IN A FEW HOURS OF STUDY WITH OUR Coaching AT HOME in Spare Time

Name and Address	License	Lessons
Lee Worthy 2210 1/2 Wilshire St., Bakersfield, Calif.	2nd Phone	16
Clifford E. Voigt Box 1018, Dania, Fla.	1st Phone	20
Francis X Forch 38 Beucler Pl., Bergenfield, N. J.	1st Phone	38

Carl E. Smith, E.E., Consulting Engineer, President

CLEVELAND INSTITUTE OF RADIO ELECTRONICS
Desk RE-45, 4900 Euclid Bldg., Cleveland 3, Ohio

TELLS HOW —

Our Amazingly Effective JOB-FINDING SERVICE

Helps CIRE'S Students Get Better Jobs

Here are a few recent examples of Job-Finding Results

OURS IS THE ONLY HOME STUDY COURSE WHICH SUPPLIES FCC-TYPE EXAMINATIONS WITH ALL LESSONS AND FINAL TESTS.

GETS BROADCAST JOB
"I wish to thank your Job-Finding Service for the help in securing for me the position of transmitter operator here at WCAB, in Pittsburgh."
Walter Koschik, 1442 Ridge Ave., N. Braddock, Pa.

GETS AIRLINES JOB
"Due to your Job-Finding Service, I have been getting many offers from all over the country, and I have taken a job with Capital Airlines in Chicago as a Radio Mechanic."
Harry Clare, 4537 S. Drexel Blvd., Chicago III.

Your FCC Ticket is recognized in all radio fields as proof of your technical ability.



Get All 3 FREE MAIL COUPON NOW

CLEVELAND INSTITUTE OF RADIO ELECTRONICS
Desk RE-45—4900 Euclid Bldg., Cleveland 3, Ohio

(Address to Desk No. to avoid delay)
I want to know how I can get my FCC ticket in a minimum of time. Send me your FREE booklet, "How to Pass FCC License Examinations" (does not cover exams for Amateur License), as well as a sample FCC-type exam and the amazing new booklet, "Money-Making FCC License Information."

Tell me about your Television Engineering Course.

Name

Address

City..... Zone..... State.....

Paste on 2-cent postcard or send air mail.

The staff of MORT FARR

of Philadelphia—one of America's leading TV Service dealers—shows

How to use



to cut down service calls

Krylon is a tough, quick-drying Acrylic coating with many important TV applications. To apply, just push the button on the aerosol can and spray—that's all you do!



Because of its high dielectric strength, Krylon helps prevent corona. Here technician Bernard Vanella "Krylon-izes" high voltage coil and insulation, the socket of the high voltage rectifier, component parts of the rectifier circuit.



Edward Weigand, Farr service man, sprays Krylon on entire antenna. Krylon shuts out moisture, rain, salt spray—prevents corrosion and pitting—keeps picture quality at peak.

"Krylon-izing" increases your customer's satisfaction and jumps your own profits! Nationally advertised to your customers!

See your jobber, or write direct.

KRYLON, Inc., Dept. 319
2601 N. Broad St., Phila. 32, Pa.

FRANCE-BRITAIN SHARE TV in first international hookup. Paris programs were carried by microwave relay link to London and rebroadcast over BBC network. Special converters adapted French 819-line pictures to British 405-line transmission standards.

A five-nation network, adding Italy, Switzerland, and West Germany (all using 625-line transmission), is expected to be in operation by 1954.

NEW FCC APPROPRIATION of \$6,408,480 carries \$300,000 earmarked for new hearing examiners to handle the huge backlog of TV-channel applications. Cut by House-Senate action from \$8,075,000 the new budget provides only half the number of examiners sought by the Commission.

IRE COMMUNICATIONS CONFERENCE in Cedar Rapids, Iowa, September 19 and 20, will feature five technical papers by outstanding authorities in addition to the exhibits, tours, and the University of Illinois, this president of Crosby Laboratories, will speak on Long-Range Communication Trends, and Dr. R. M. Page, associate director of research for Electronics, Naval Research Laboratory, will present a Comparative Study of Modulation Methods.

8TH NATIONAL ELECTRONICS CONFERENCE will be held September 29, 30, and October 1 at the Sherman Hotel in Chicago. Sponsored by the AIEE, IRE, Illinois Institute of Technology, Northwestern University, and the University of Illinois, this year's conference will include participation by other universities and the Society of Motion Picture and Television Engineers. Dr. J. A. M. Lyon of Northwestern Technological Institute has been named president.

PROFESSOR A. C. B. LOVELL'S article on the Jodrell Bank radio telescope, referred to on page 10 of the July, 1952, **RADIO-ELECTRONICS**, appeared in July, 1951, not in May, 1951, as stated in this department in July.

NEW DIVERSITY TRANSMISSION helps mobile communications receivers overcome static and fading where utmost dependability is vital. Developed by RCA, the system is the outgrowth of long experience with space-diversity reception, where fading at one location is generally accompanied by an increase in signal strength some distance away. Combining the outputs of two or more receivers fed by widely separated antennas and controlled by a common a.g.c. system gives a highly uniform output.

Similar results are now obtained with spaced transmitters and a single receiving antenna. Recent tests between Bolinas, California, and New York showed signals 4 to 30 times stronger with the new system.

FRENCH-LANGUAGE RADIO NETWORK for central and western Canada was approved by CBC. Six stations will be added: two each in Ontario and Saskatchewan, one each in Manitoba and Alberta. A 15-station network now serves Quebec, Canada's largest French-speaking province.

EIDOPHOR COLOR-TV SYSTEM for theater use (first reported here in the October, 1946, issue of this magazine) was demonstrated recently in New York City by Twentieth Century-Fox Film Corporation. Still under development, the Swiss-invented system projects an electronically-formed image by familiar film-projection technique on a standard theater-size motion-picture screen.

Instead of depending on the light generated by the electron beam of the picture tube, the Eidophor system uses an arc-lamp as a source of illumination. Its light is modulated by the television signal.

The system was described completely in this magazine in October 1946, but at that time the equipment was very cumbersome, occupying three stories of the building in which it was installed.

The photograph shows the complete Eidophor installation in its present form.

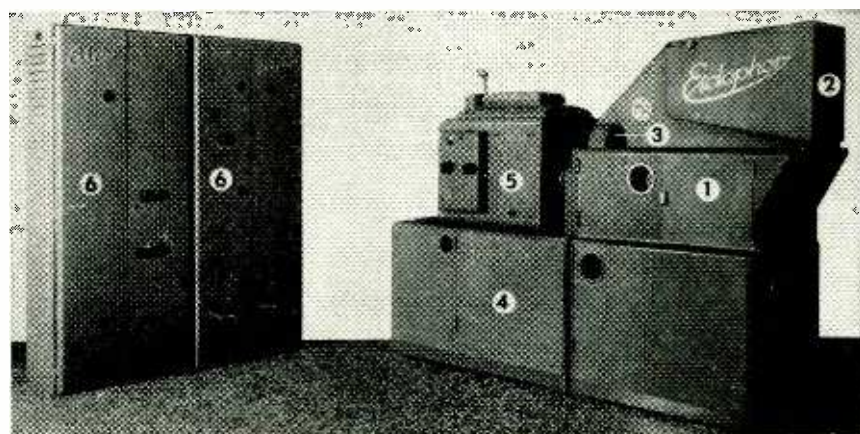

Eidophor installation. 1—Projector. 2—Projection light-beam hood. 3—Color wheel. 4—Auxiliary units (vacuum pump, thermostat, and cooling system). 5—Projection lamp (Ventarc type). 6—Television receivers and power-supply units.

THE ONLY COMPLETE CATALOG FOR EVERYTHING IN TELEVISION, RADIO AND INDUSTRIAL ELECTRONICS

your 1953
ALLIED **free!**
236-PAGE CATALOG
complete...value-packed



Send for it Today!

Here's the *one* authoritative, complete Buying Guide to *Everything in Electronics*—packed with the world's largest selections of quality equipment at lowest, money-saving prices. See the latest in TV, AM and FM receivers; High-Fidelity Custom Sound components; latest P.A. Systems and accessories; recorders; Amateur receivers, transmitters and station gear; specialized industrial electronic equipment; test instruments; builders' kits; huge listings of parts, tubes, tools, books—the world's *most complete stocks* of quality equipment.

ALLIED gives you every buying advantage: speedy delivery, expert personal help, lowest prices, liberal time payment terms, assured satisfaction. Get the latest 1953 ALLIED Catalog. Keep it handy—and save time and money. Send for your **FREE** copy today!

the world's largest stocks

- TV and Radio Parts
- Test Instruments
- Hi-Fi and P.A. Equipment
- Television & Home Radios
- Recorders and Supplies
- Amateur Station Gear
- Builders' Supplies
- Equipment for Industry

quick, expert service

EVERYTHING IN ELECTRONICS

ALLIED RADIO
 World's Largest Radio Supply House



free

Send Today for Radio's Leading Buying Guide

EASY-PAY TERMS

Take advantage of ALLIED'S liberal Easy Payment Plan—Radio's best terms—only 10% down, 12 months to pay—no interest if you pay in 60 days. Available on Hi-Fi and P.A. units, recorders, TV chassis, test instruments, Amateur gear, etc.

TV & HI-FI SPECIALISTS

To keep up with developments in TV and High-Fidelity, look to ALLIED! Count on us for all the latest releases and largest stocks of equipment in these important fields. If it's *anything* in Television or High-Fidelity equipment—we have it in stock!

ALLIED RADIO CORP., Dept. 2-J-2
 833 W. Jackson Blvd., Chicago 7, Illinois

Send FREE 236-Page 1953 ALLIED Catalog

Name _____

Address _____

City _____ Zone _____ State _____

CHANNEL MASTER

proudly introduces

the world's first Broad Band Yagi

the

f·u·t·u·r·a·m·i·c

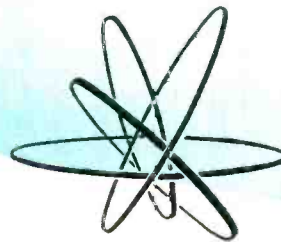

**A great new type of antenna
that combines:**



Broad Band coverage *with the*



high gain and directivity of the Yagi

Spectacular high gain! Razor-sharp directivity! In fact, all the brilliant performance that only a Yagi can deliver, is now yours with the FUTUFAMIC — not on just one channel, but CLEAR ACROSS THE BAND!

For the first time in television history, here is an antenna that not only solves today's installation problems — but also provides for the new VHF channels of the future. This is the antenna you have been waiting for — the 10 Element FUTUFAMIC is a true Broad Band Yagi!

the antenna designed for today and tomorrow!

The same FUTURAMIC that . . .

- ✧ Solves **today's** reception problems
- ✧ Will also receive **tomorrow's** new VHF channels

THE FUTURAMIC MEANS BIG BUSINESS FOR YOU IF YOU SERVE ANY OF THESE 3 BOOMING VHF MARKETS!

1. Areas in which the FCC has ordered VHF stations to change channels (on the same band).

When a channel-shift takes place, the thousands of single-channel Yagis in use will become obsolete overnight. The set owner will face a dilemma: If he changes his antenna before the channel-shift, he will be without reception until the shift occurs. If he waits until the station changes channels, he will be without reception until his new antenna is installed. You can install the Futuramic now — before the rush starts! It will provide better reception than conventional Yagis on the present channels—and when the shift occurs, this superior reception will continue on the new channel without interruption!

2. Areas in which a new VHF station is being added to the present one.

The hundreds of thousands of single-channel Yagis now in use will not bring in the new channel. This means that an additional Yagi will have to be installed and tied into the present installation with a separate lead, through an annoying switching system. However, one Futuramic will do the job of both antennas — at lower cost — with better results on each channel. Install the Futuramic now to improve your present picture. And at the same time be ready for future channels on the same band.

3. Areas served at present by two or more VHF stations (on the same band).

In such areas, the installation man must choose between conventional broad band antennas and separate Yagis for each channel. Each approach has important advantages. Only the Futuramic will give you the advantages of BOTH, combining highest gain, and sharpest directivity on each channel with simple, economical installation.

Model No.	Channels Covered	List Price
1173	7, 8, 9, 10, 11, 12, and 13	\$2083
1124	2, 3, and 4	\$4097
1125	2, 3, 4, and 5	
1136	3, 4, 5, and 6	
1146	4, 5, and 6	

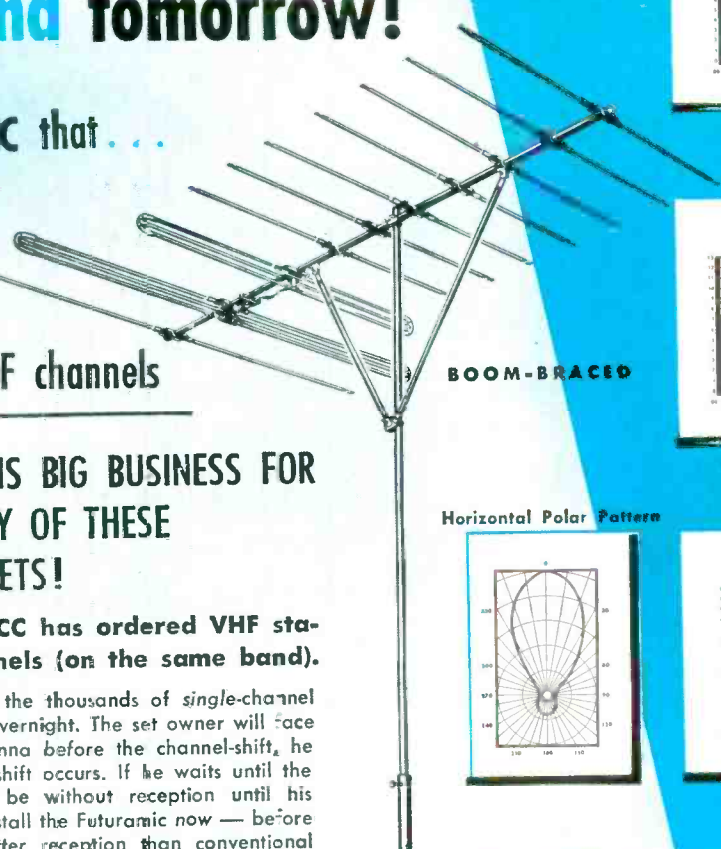

BOOM-BRACED

Horizontal Polar Pattern

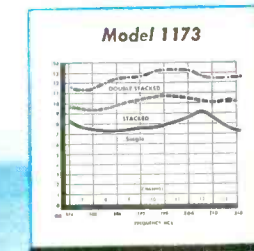
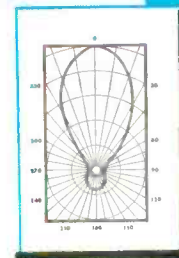

Covers Ch. 7, 8, 9, 10, 11, 12, 13

GAIN CURVES

Model 1124

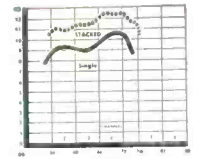

Covers Ch. 2, 3, 4

Model 1125

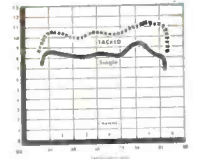

Covers Ch. 2, 3, 4, 5

Model 1146

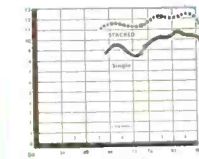

Covers Ch. 4, 5, 6

Model 1136

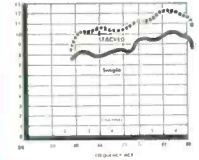

Covers Ch. 3, 4, 5, 6

ALL THIS AND Z-MATCH TOO!

The Futuramic uses Channel Master's famous Z-Match system which eliminates mismatch, gives maximum stacking gain, and provides stacking bars at no extra cost.

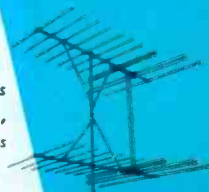

SHATTERS all performance records!

- Channel for channel, the Broad Band Futuramic will outperform any conventional SINGLE-CHANNEL Yagi!
- On each of its specified channels, one single Low Band Futuramic will outperform any 4-bay conical or fan array!
- A single High Band Futuramic will outperform any 2-bay conical or fan array on every channel from 7 to 13!
- A high-low Futuramic combination is the most sensitive array ever devised for all-channel VHF reception!

Write for complete technical literature.



CHANNEL MASTER CORP. ELLENVILLE, N.Y.



USE PHOTOFAC

the world's best Radio and TV Service Data...

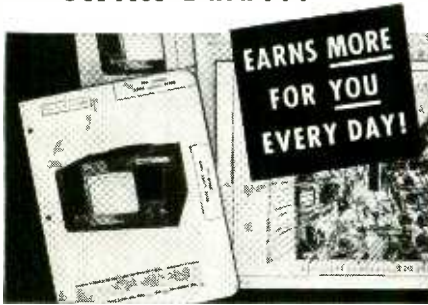

WE'LL PROVE YOU'LL SAVE TIME and EARN MORE WITH PHOTOFAC

FREE Service Technicians: We'll send you any Photofact Folder listed in the "PF INDEX and Technical Digest." If you

haven't an Index, get a free copy from your local Photofact distributor or write for it today. To obtain Free Folder, be sure to state Photofact Set and Folder Number as shown in the Index.

NOW—learn for yourself how PHOTOFAC makes your Radio and TV work quicker, easier, more profitable! Just get and use an actual PHOTOFAC Folder. Discover why over 35,000 successful service technicians count on this invaluable data daily. No other service gives you PHOTOFAC's completeness, accuracy, uniformity and lowest cost. PHOTOFAC is the only Radio-TV service data prepared from laboratory analysis on the actual equipment. Get your FREE Folder now. Examine, use, compare. See why you can't afford to be without PHOTOFAC!

NOTE: Our FREE Folder offer is limited to Service Technicians only. Attach coupon below to your letterhead and mention your jobber's name. Experimenters and others may obtain the Photofact Folder by remitting amount shown below.

HOWARD W. SAMS & CO., INC.

HOWARD W. SAMS & CO., INC.
2201 E. 46th St., Indianapolis 5, Ind.

I am a Service Technician. Send me Free Folder No. which appears in Photofact Set No. (as listed in the PF Index).

I am an Experimenter. Enclosed \$ Send me Folder No. which appears in Photofact Set No. (TV—\$1.00. AM/FM—50c. Record Changer. or Communication Receiver—75c)

Name.....

Address.....

City.....Zone.....State.....

EASY PAY PLAN!

PAY AS YOU EARN! Ask your distributor about this amazing plan. Only \$18.39 puts the entire profit-boosting Photofact library in your shop now!

NAVY'S NEW BISMANOL MAGNETS have the highest coercive force known, use no critical nickel or cobalt. Developed in the Naval Ordnance Laboratory, Bismanol is an alloy of bismuth and manganese, both non-magnetic elements. Equal to Alnico in maximum energy product (3×10^6

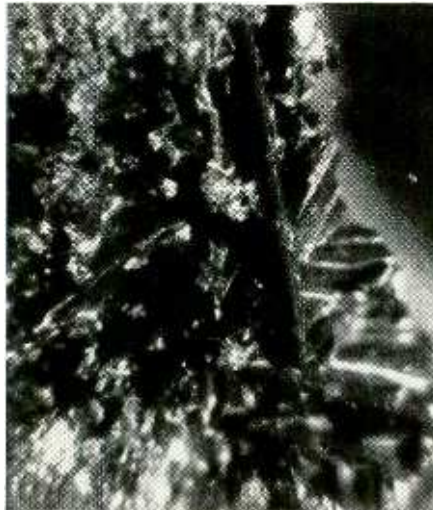

Photomicrograph of Bismanol crystals.

gauss-oersteds), Bismanol has the further advantage that it can be pressed at relatively low temperatures into complicated shapes. The photograph shows microscopic crystals of the new magnetic material before separation from the basic alloy.

ADHESIVE-TAPE RESISTORS, developed some time ago by the National Bureau of Standards for printed circuits, now are pre-cured for immediate use without further treatment. In the new form, wire or metal-ribbon leads

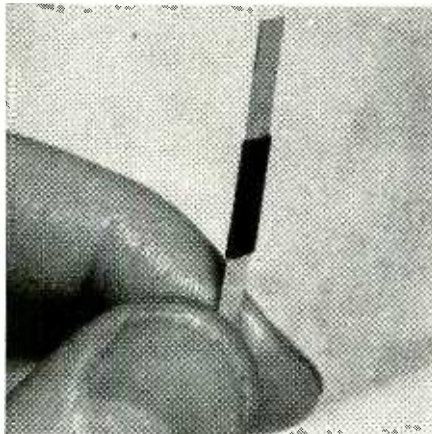

New pre-cured adhesive-tape resistor.

are sandwiched between two resistor tapes. The assembly is then heat treated to stabilize the resistance and seal the lead contacts. The cured unit may be soldered or spot-welded directly in the circuit. The photograph shows the appearance of the new resistors.

END OF COLOR-TV BAN, reported in June by National Production Authority means little to set owners and manufacturers, say industry spokesmen. Continued restrictions on use of

materials and personnel for nondefense production block any immediate resumption of color-set manufacture.

EMERSON RADIO GIVES \$100,000 in grants of \$10,000 each to the first 10 educational-TV licensees to begin regular programs. In announcing the gift, Emerson president Benjamin Abrams called on industry to establish a \$5 million fund which would help set up noncommercial stations as quickly as possible throughout the country. Mr. Abrams also proposed a national council of outstanding educators, artists, scientists, and public leaders to develop the cultural potentialities of educational TV.

BRIGADIER GENERAL SARNOFF—chairman of the board of directors of RCA—was awarded RTMA's first Medal of Honor at the association's recent annual convention. RTMA chairman Robert C. Sprague presented the award as a tribute from General Sarnoff's colleagues, "in recognition of many notable achievements toward the development and progress of the radio-television industry."

PRESIDENTIAL COMMUNICATIONS CAR, designed by the Army Transportation Corps and Signal Corps, is now in service. Through its advanced facilities the Chief Executive



The President's new communications car.

can communicate with Washington by radio or wire from any part of the country. The photograph of the control console shows only part of the receiving and transmitting equipment. Multiple antennas, some demountable, provide dependable communications even while the President's train is in motion.

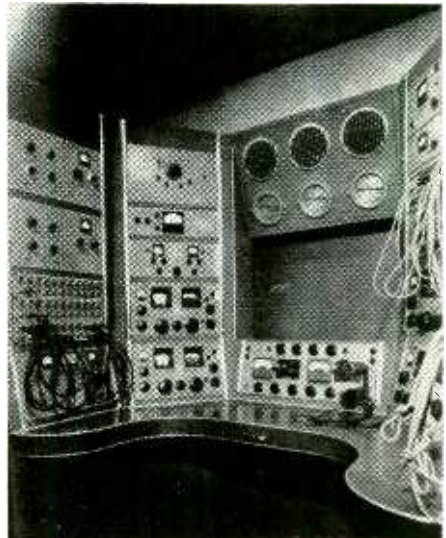

Photos courtesy Hammarlund Mfg. Co.
Radio section of the control console.

the greatest Yagi of them all

JFD 10-ELEMENT "Baline" YAGI

***12 db** (gain of stacked JFD BALINE over a tuned folded dipole)

***9½ db** (gain of single JFD BALINE over a tuned folded dipole)

*These figures have been verified by the Hazeltine Corporation, world famous research laboratory. All JFD gain figures are based on a reference tuned folded dipole. Beware of exorbitant gain figures which are not based on any reference level.

ACTUAL FIELD TESTS PROVE IT

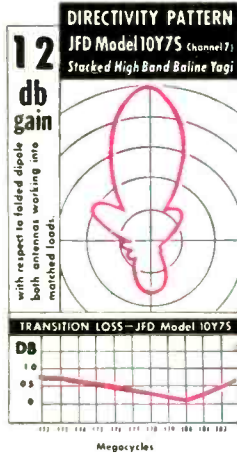
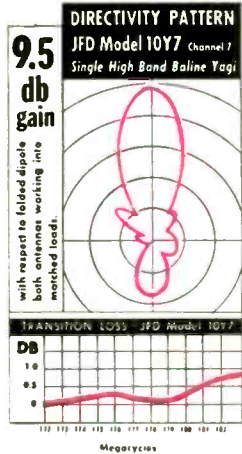

Single JFD High Band BALINE Yagis

Channels	Models	List Price
7-13	10Y7-10Y13	\$13.85

Stacked JFD BALINE Yagis

Channels	Models	List Price
2	10Y2S	\$63.70
3	10Y3S	63.70
4	10Y4S	56.90
4-5	10Y45S	67.80
5	10Y5S	56.90
6	10Y6S	51.40
7-13	10Y7S-10Y13S	27.70

Include JFD Baline matching transformers at no extra charge

Single JFD Low Band BALINE Yagis

Channels	Models	List Price
2	10Y2	\$31.85
3	10Y3	31.85
4	10Y4	28.45
4-5	10Y45	33.90
5	10Y5	28.45
6	10Y6	25.70



illustrated: JFD No. 10Y2S-10Y6S Low Band Stacked Baline Yagi



The antenna sensations of the Nation!

JETENNA... the conical with jet-action assembly
...no other fan conical assembles so fast, performs so well!



1. Pre-assembled JFD JeTenna as packaged. Note its compactness of construction and craftsmanship of design.

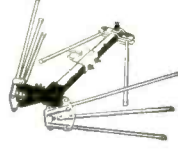

2. As the JeTenna swings open, dipole elements fan instantly into exact position by riding along unique fulcrum indices.



3. JeTenna elements lock into position effecting 35° forward inception angle and 40° dipole angulation for greater signal pickup. Reflectors snap into place for quick tightening by wing nuts.

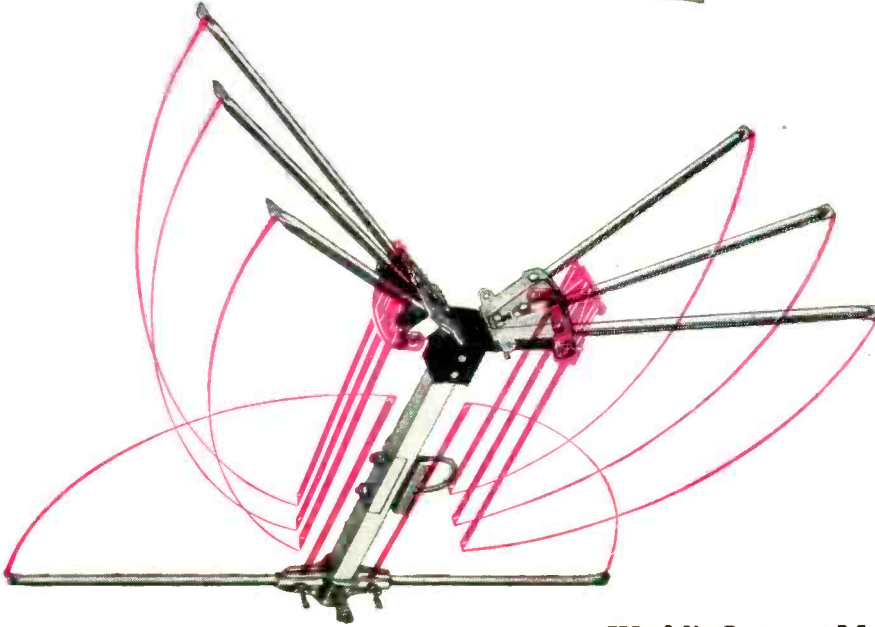

Series with 1" seamless aluminum square crossarm and seamless aluminum elements reinforced with Fibreglas dowels.

No. JET160	Single Bay	Up to 8.8 db*	\$12.50 list
No. JET161	2 Bay	Up to 12.5 db*	\$26.40 list
No. JET164	4 Bay	Up to 15.5 db*	\$56.80 list

Series with 1" seamless square aluminum crossarm and wood-doweled butt-seam aluminum elements.

No. JET660	Single Bay	Up to 8.8 db*	\$ 9.75 list
No. JET661	2 Bay	Up to 12.5 db*	\$20.70 list
No. JET664	4 Bay	Up to 15.5 db*	\$45.40 list

*Performance tested and figures verified by the Hazeltine Corporation, Little Neck, N.Y. World Famous Research Laboratory.

JFD MFG. CO.
BROOKLYN 4, N. Y.
BENSONHURST 6-9200





Tung-Sol "Quality Control" recognizes but one standard. All Tung-Sol Tubes meet the highest original equipment requirements of leading radio and tv set manufacturers! Use Reliable Tung-Sol Tubes.

TUNG-SOL ELECTRIC INC.
Newark 4, N. J.

Sales Offices: Atlanta • Chicago • Culver City
Dallas • Denver • Detroit • Newark

TUNG-SOL MAKES:

All-Glass Sealed Beam Lamps, Miniature Lamps, Signal Flashers, Picture Tubes, Radio, TV and Special Purpose Electron Tubes.



TUNG-SOL
RADIO, TV TUBES, DIAL LAMPS



Here's a real lively "stopper" to attract attention to your place of business and emphasize the quality of your service. Colorful—bright red and two shades of blue. 15 inches high. Your jobber salesman will tell you how to get one.



BAROMETER of the PARTS INDUSTRY

During July, 51 of the leading 400 manufacturers of radio-television-electronic parts and equipment made changes in their lines. Actually there was a decrease in "change activity" as compared to June. In price revisions by the number of manufacturers and products affected, the following summary illustrates the comparative trend for the months of June and July.

	No. of Manufacturers		No. of Products	
	June	July	June	July
Increased prices	10	4	67	7
Decreased prices	16	17	315	88

For a summary of the most active product categories, see the following table:

Product Group	Increased Prices		Decreased Prices		New Products		Discontinued Products	
	No. of Mfrs.	No. of Products	No. of Mfrs.	No. of Products	No. of Mfrs.	No. of Products	No. of Mfrs.	No. of Products
Antennas & Access.	0	0**	1	0**	11	106**	4	20**
Capacitors	0	0	1	2*	2	42*	0	0
Controls & Resistors	0	0	0	0	1	2**	1	235*
Power Supplies	0	0	0	0	1	19	1	2
Sound & Audio	0	0	3	8**	16	173*	0	0**
Test Equipment	0	0**	0	0	6	37*	1	2**
Transformers	0	0	0	0	1	117*	0	0
Tubes	2	5**	7	44**	7	41*	2	5**

* Increase over June
** Decrease from June

* Increase over June
** Decrease from June

Comment: Activity in the electronic industry continues to center upon the introduction of new products with antenna and audio manufacturers being the most active. Price increases and decreases remain quite minor with revisions occurring among tube manufacturers.

This data is prepared by the staff of United Catalog Publishers, Inc., 110 Lafayette Street, New York City, publishers of RADIO'S MASTER, the Official Buying Guide of the Parts Industry.

Merchandising and Promotion

RCA Victor embarked on the largest and most comprehensive advertising campaign for its TV and radio receivers and phonographs in company history. The third-quarter drive made prolific use of consumer magazines and newspapers, backed up by trade-press and direct-mail advertising, radio and television commercials and point-of-purchase displays.

Simpson Electric Co., Chicago, released a new two-color envelope stuffer giving illustrations, specifications, and other pertinent data on its instruments for TV and FM servicing. Data on the new Simpson model 485 synchronized cross-hatch pattern generator is included.

Insuline Corp. of America, Long Is-



land City, N. Y., is offering its distributors a new counter display card to promote the sale of its concealable indoor antennas for FM and television reception.

RCA's Tube Department devised a special "Converkit" containing the company's first "universal" horizontal-deflection-output and high-voltage transformer and a ferrite-core deflecting yoke, for converting small-screen television receivers to use picture tubes up to 21 inches. The kit was designed as an attractive display and to simplify the service technician's stock problems.

New Plants and Expansions

Allen B. Du Mont Laboratories established a new replacement sales department of its Cathode-Ray Tube Division. Edwin B. Hinck, previously manager of electronics parts sales, heads the new department, with headquarters in Clifton, N. J.

General Electric opened a new \$6,000,000 electronic tube plant near Anniston, Ala. At the dedication ceremonies Ralph J. Cordiner, president of G-E, announced that within the next two years the Southeastern area of the United States will become a major center in the company's operations.

RMS, New York City, acquired a new plant at 2016 Bronxdale Ave., which provides approximately 45,000 square feet of space. The company's Antenna Division will remain at its West Farms Road plant. The former plant and

Here's your Opportunity

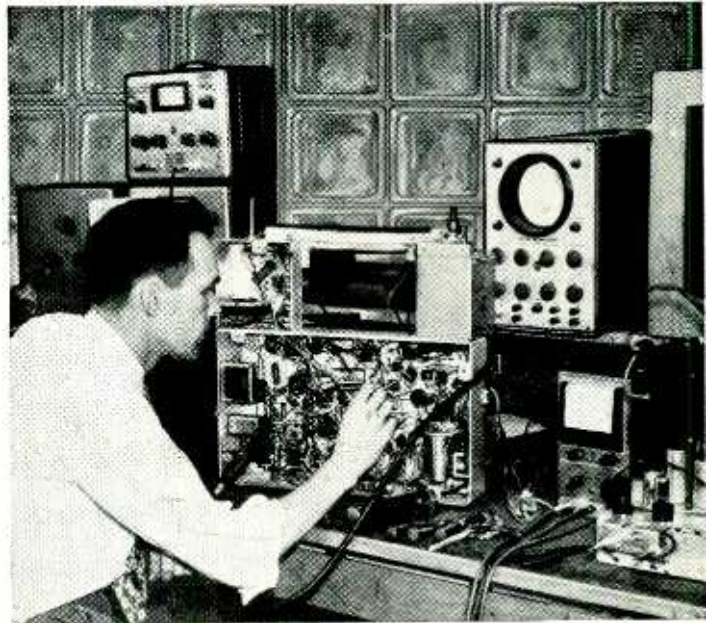

to prepare for a good job or a business of your own in TV SERVICING

There are today more good jobs open in TV Servicing than there are trained and experienced men to fill them. Yes, thousands of opportunities exist now for good-pay jobs offering employment security for years and years to come. Thousands of TV Servicing jobs are going begging. Do you want one of them?

Experts agree, that because of the critical shortage of trained and experienced TV Servicemen, and the tremendous future growth of the industry, no vocational field today offers more opportunities than TV Servicing.

The Big New Industry with a Great Future

Television is just in the beginning stages of its big industrial boom. Look at these amazing facts:

- Lifting the freeze on new TV stations will open many new TV areas and will improve the coverage of existing areas. The result will be an enormous demand for TV receivers.

- Within a few years over 1000 TV stations will be telecasting compared with 108 TV stations now on the air.
- Nearly one-half of all families living within the present TV areas do not yet own TV receivers.
- The new trans-continental video network plus better and more interesting programs plus larger viewing screens and color TV will increase the installation of new receivers, will induce present owners of 12-inch and smaller size viewing screens to buy newer model receivers.
- The power increases of many existing stations and improved reception range of current receivers will result in receivers being installed and serviced in the fringe areas of present stations.
- Under the FCC proposal, over 70 per cent of all communities will be served by UHF channels exclusively. This means TV servicemen must know UHF receivers before the new UHF stations in their area are opened.

- No one yet knows how great the industrial TV market will be.

RCA Institutes Home Study Course prepares you for a Career in TV Servicing

The addition of the RCA Institutes TV Service Training to your present radio-electronics experience will qualify you to step out and grasp the golden opportunities that now exist in television—America's fastest growing industry.

Learn at home—in your spare time—while you study the practical *how-to-do-it* techniques with *how-it-works* information. Easy-to-read and easy-to-understand lessons under the supervision of RCA engineers and experienced instructors quickly train you to qualify for the many good jobs now waiting for trained TV servicemen. Don't pass up this lifetime opportunity for financial security and a bright future in TV. Learn TV Servicing from RCA—pioneers and leaders in radio, television and electronic developments.

RCA Institutes conducts a resident school in New York City offering day and evening courses in Radio and TV Servicing, Radio Code and Radio Operating, Radio Broadcasting, Advanced Technology. Write for free catalog on resident courses.

Send for FREE BOOKLET

Mail the coupon—today. Get complete information on the RCA INSTITUTES Home Study Course in Television Servicing. Booklet gives you a general outline of the course by units. See how this practical home study course trains you quickly, easily. Mail coupon in envelope or paste on postal card.



MAIL COUPON NOW!

RCA INSTITUTES, INC., Home Study Department RE-952
350 West Fourth Street, New York 14, N. Y.

Without obligation on my part, please send me copy of booklet "RCA INSTITUTES Home Study Course in TELEVISION SERVICING." (No salesman will call.)

Name _____ (please print)
 Address _____
 City _____ Zone _____ State _____



RCA INSTITUTES, INC.
 A SERVICE OF RADIO CORPORATION OF AMERICA
 350 WEST FOURTH STREET, NEW YORK 14, N. Y.

NEW GENERAL ELECTRIC

"Golden Treasure"

CARTRIDGE



First wide range diamond-and-sapphire combination delivers frequency response from 30 to 15,000 cycles. Tracks all 3 speeds at 6 to 8 grams

High fidelity performance of custom quality—at the lowest price in G-E history—that sums up what audio engineers at Electronics Park have achieved with this latest de luxe addition to the General Electric cartridge line.

The replaceable stylus is of the famous double-twist design. A total of six damping blocks filter out harmonic distortion, needle talk and needle scratch. There are no moving parts in

this cartridge—nothing to wear out. Remember—when you replace a stylus assembly in a G-E pickup, you replace every component that is affected by age. A new stylus assembly means, in effect, a new pickup.

Ask your G-E dealer about the Golden Treasure cartridge, or write us for the nearest source of supply. *General Electric Company, Electronics Park, Syracuse, N. Y.*

You can put your confidence in—

GENERAL  ELECTRIC

SEND FOR THESE NEW CATALOGS!

General Electric Company
(Section 382)
Electronics Park,
Syracuse, N. Y.



Please send me the items checked:

- Phono Accessory Catalog Loudspeaker Catalog
 Wide Range Stylus Folder

NAME.....

ADDRESS.....

CITY.....STATE.....

J. E. SMITH
President
National Radio
Institute
Washington, D. C.



I Will Train You at Home

for Good Pay Jobs, Success in

RADIO-TELEVISION



YOU LEARN SERVICING
by practicing with equipment I furnish

You build valuable Multitester (at left) as part of my Servicing Course. You use it to make many tests, get practical experience, make EXTRA money fixing neighbors' radios in spare time. Many of my students earn \$5, \$10 a week extra while learning. I send you many other kits too. You build a modern Radio. You build many circuits common to Radio and Television. All equipment is yours to keep. Read about and see other equipment in my free book. Mail card below.



YOU LEARN COMMUNICATIONS
by practicing with equipment I furnish

As part of my Communications Course I send you kits of parts to build the low power broadcasting transmitter shown at right and many other circuits common to Radio and Television. You use this equipment to get practical experience putting a station "on the air," performing procedures demanded of Broadcast Station operators. I train you for FCC Commercial Operator's License. Mail Card for Sample Lesson and 64-Page Book. FREE!



TELEVISION is Today's
Good Job Maker

In 1951 over 15,000,000 homes had Television sets, more are being sold every day. 108 TV stations are already operating, over 1800 are now authorized and many hundreds are expected to be on the air in 1953. This means new jobs, more jobs and better pay for trained men. The time to act is NOW! Start learning Radio-Television servicing or communications. Want to get ahead? America's fast growing industry offers good pay, a bright future and security. Cut out and mail card now. J. E. Smith, President, National Radio Institute, Washington, D.C.

There are Good Jobs, Good Pay, Success in Radio-TV! SEE OTHER SIDE

CUT OUT AND MAIL THIS CARD NOW

Sample Lesson & 64-Page Book

Both FREE

This card entitles you to Actual Lesson on Servicing, shows how you learn Radio-Television at home. You'll also receive my 64-Page Book, "How to Be a Success in Radio-Television." Mail card now!

NO STAMP NEEDED! WE PAY POSTAGE

Mr. J. E. SMITH, President,
National Radio Institute, Washington 9, D.C.

Mail me Lesson and Book, "How to Be a Success in Radio-Television." (No Salesman will call. Please write plainly.)

NAME AGE

ADDRESS

CITY ZONE ... STATE

The ABC's of
SERVICING

How to Be a
Success
in RADIO-
TELEVISION

Train at Home to Jump Your Pay as a RADIO-TV Technician



**J. E. Smith, President
National Radio Institute**

The men whose letters are published below were not born successful. At one time they were doing exactly as you are doing now... reading my ad! But they acted. They decided they would know more... so they could earn more! They acted! Mail the card now for my 2 books FREE.

There's a Bright Future for You in America's Fast Growing Industry

Do you want good pay, a job with a bright future, security? Would you like to have a profitable business of your own? If so, find out how you can realize your ambition in the fast growing RADIO-TELEVISION industry. Even without Television, the industry is bigger than ever before. 105 million home and auto radios, 2900 Radio Broadcasting Stations, 108 TV Stations with 1800 more now authorized. Expanding use of Aviation and Police Radio, Micro-Wave Relay, Two-Way

Radio for buses, taxis, etc., are making opportunities for Servicing and Communications Technicians and FCC Licensed Operators.

You Learn by Practicing with Kits I Furnish

With both my Servicing Course and my NEW Communications Course I send you many Valuable Kits of Parts. They "bring to life" theory you learn in my illustrated texts. Mail card for my big 64-page book. It shows photos of equipment you build from kits I send.

My Training Includes Television

Both my Servicing and Communications Courses include lessons on TV principles. You get practical experience by working on circuits common to both Radio and Television. My graduates are filling jobs, making good money in both Radio and Television. Remember, the way to a successful career in Television is through experience in Radio.

Send NOW for 2 Books FREE

Mail the Postage-Free Card NOW!

What will YOU be doing one year from today... will you be on your way toward a good job of your own in a Radio and Television service shop or business? Decide now that you are going to know more and earn more! ACT NOW! Take the important first step to a career and security. Send the postage-free card now for my FREE DOUBLE OFFER. You get Actual Servicing Lesson. Also my 64-page book, "How to Be a Success in Radio-Television." Read what my graduates are doing, earning; see equipment you practice with at home. Mail card now. J. E. SMITH, President, National Radio Institute, Washington 9, D.C. Our 39th year.

NRI Training Can Lead to Jobs Like These in RADIO-TELEVISION

BROADCASTING

Chief Technician
Chief Operator
Power Monitor
Recording Operator
Remote Control Operator

SERVICING

Home and Auto Radios
P. A. Systems
Television Receivers
Electronic Controls
FM Radios

IN RADIO PLANTS

Design Assistant
Transmitter Design Technician
Service Manager
Tester
Serviceman
Research Assistant

SHIP AND HARBOR RADIO

Chief Operator
Assistant Operator
Radiotelephone Operator

GOVERNMENT RADIO

Operator in Army, Navy, Marine Corps, Coast Guard
Forestry Service
Dispatcher
Airways Radio Operator

AVIATION RADIO

Plane Radio Operator
Transmitter Technician
Receiver Technician
Airport Transmitter Operator

TELEVISION

Pick-up Operator
Voice Transmitter Operator
Television Technician
Remote Control Operator
Service and Maintenance Technician

POLICE RADIO

Transmitter Operator
Receiver Serviceman

I TRAINED THESE MEN



Handicapped but Successful

"I am now Chief Engineer at WHAW. My left hand is off at the wrist. A man can do... if he wants to." R. J. Bailey, Weston, W. Va.



\$10 a Week In Spare Time

"Before finishing, I earned as much as \$10 a week in Radio servicing, in my spare time. I recommend NRI." S. J. Petrucci, Miami, Fla.



Control Operator, Station WEAN

"I received my license and worked on ships. Now with WEAN as control operator, NRI course is complete." R. Arnold, Rumford, R. I.



Trained Men Make Money In TV

"I am now servicing Television. Your course enabled me to repair TV receivers without any trouble." R. Currier, Fair Haven, Vt.



Has Growing Business

"Am becoming expert Electrician as well as Radiotician. Without your course this would be impossible." P. Brogan, Louisville, Ky.



Got First Job Thru NRI

"My first job was with KDLR. Now Chief Engr. of Radio Equipment for Police and Fire Dept." T. Norton, Hamilton, Ohio.

Find Out What RADIO-TV Offers You

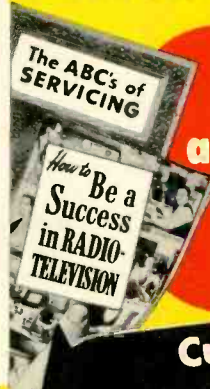

SAMPLE LESSON and 64-PAGE BOOK Both FREE

Cut out and mail postage-free card today!

Make Extra Money While Learning

Keep your job while training. Many NRI students make \$5, \$10 and more a week extra fixing neighbors' Radios in spare time while learning. I start sending you special booklets that show you how to service sets the day you enroll. Multi-tester you build with parts I furnish helps discover and correct Radio troubles.



Want Your Own Business?

Many N.R.I. trained men start their own business with capital earned in spare time. Let me show you how you can be your own boss... Robert Dohmen, New Prague, Minn., (whose store is shown at right) says, "Am now tied in with two television outfits and do warranty work for dealers. Often fall back to N.R.I. textbooks for information on installing Television sets."



FIRST CLASS

Permit No. 20-R

(Sec. 34.9, P.L. & R.)

Washington, D.C.

BUSINESS REPLY CARD

No Postage Stamp Necessary If Mailed In The United States

4c POSTAGE WILL BE PAID BY
NATIONAL RADIO INSTITUTE

16th and U Sts., N.W.

Washington 9, D. C.

general offices will be retained as a warehouse.

Kaiser Manufacturing Corp., Willow Run, Mich., a subsidiary of Kaiser-Frazer Corp., took its first step into the electronics field with the establishment of the Kaiser-Sanders Electronics Division, Nashua, N. H. Sanders Associates, Inc., Waltham, Mass., subleased space from Kaiser and moved its research and development laboratories to the new facility.

Raytheon Manufacturing Co., Waltham, Mass., gave the public an opportunity to inspect its South Quincy, Mass., receiving tube plant at an "open



Mayor Henry A. Turner of Waltham, Mass., flanked by Raytheon officials, formally opens company's new building.

house" marking the Raytheon Tube Division's 30th year of operation. The company also dedicated its Seyon Street plant in Waltham which will be used by the Research Division in carrying on the company's \$2,000,000 transistor program.

Galvanic Products Corp., New York City, established a new plant at Valley Stream, N. Y., for the manufacture of selenium rectifiers, complete rectifier equipment, and allied components.

Sarkes Tarzian Rectifier Division added approximately 3,000 square feet to its facilities in Bloomington, Ind., for research and engineering work.

The Gabriel Laboratories has been established as a separate division of The Gabriel Co. The Laboratories, formerly the Engineering Department of Workshop Associates, will serve as the research and development center for all Gabriel divisions.

Parkside Wire Co., Chicago, recently formed wire and wire products manufacturing firm, expanded its facilities to include industrial and jobber sales.

Mercury Electronic Co., Red Bank, N. J., was recently founded by Andrew Munchak, Jr., formerly with Electronic Measurements Co. The new firm will manufacture static converters, regulated power supplies, specialized electronic equipment and other items.

Allied Radio Corp., broke ground for its new \$2,000,000 building in central Chicago, which will provide 150,000

Now the one definitely better television booster

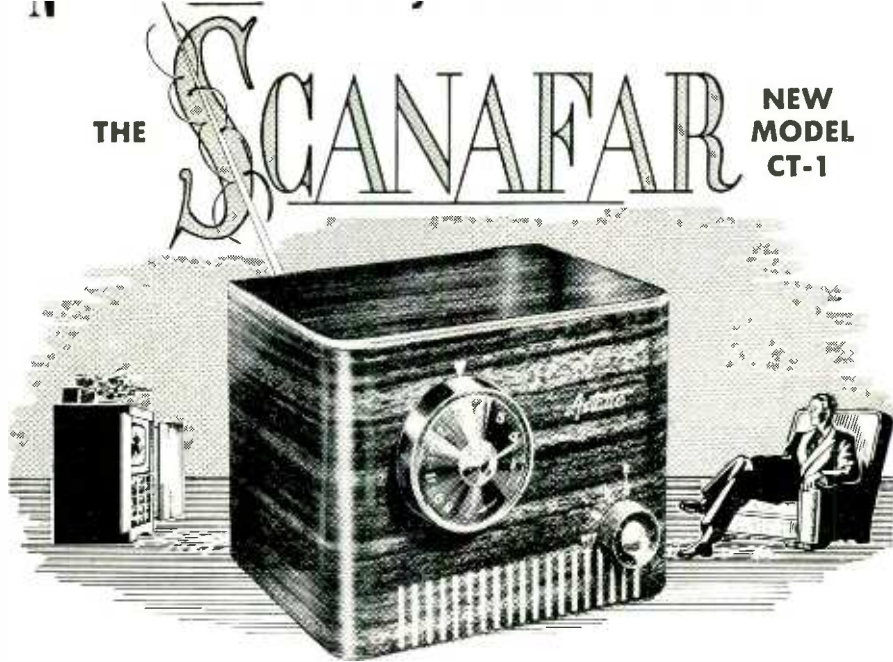

by Astatic Great, major improvements in new television receivers have left ordinary boosters wanting. Where such boosters had been able to effect some slight improvement in the reception obtained with older model sets, the new sets have actually been found to suffer, in picture clarity and definition, when oldstyle boosters are cut into the circuit. That's why Astatic's new Scanafar TV Booster, model CT-1, is causing such a stir in trade circles. Here is a booster of brand-new design that more than meets the tougher requirements of today . . . works to the advantage of the best new receiver front-ends . . . makes fine reception finer and poor reception fine . . . imposes no loss of picture definition nor suppression of sound. The Scanafar is truly the one definitely better TV Booster. Your first trial hook-up will show the real difference.

LIST PRICE \$32.50

FEATURES

The Scanafar employs a balanced, cascaded circuit, with a neutralized 6J6 tube driving a 6BQ7 (the highly touted "quiet tube"). Both tubes are used over the entire TV frequency range. Band width is over seven megacycles on all channels. Provision is made for either 72 ohm or 300 ohm impedance input and output. For other descriptive and technical information, write for illustrated literature.

THE **Astatic** CORPORATION
 CONNEAUT, OHIO
IN CANADA: CANADIAN ASTATIC LTD., TORONTO, ONTARIO

EXPORT DEPARTMENT

401 Broadway, New York 13, N. Y. Cable Address: ASTATIC, New York

★★★★★★★★★
 ★ Get window-size
 ★ reprints of this ad
 ★ free from your
 ★ Sprague distribu-
 ★ tor, or send 10c to
 ★ Sprague to cover
 ★ handling costs.
 ★★★★★★★★★★



HERE'S YOUR ANSWER, MR. AND MRS. SETOWNER!

999 times out of a thousand, when this happens . . . *don't blame your service technician!*

The repair to your television receiver made several days ago or even several months ago probably had no relation to the new trouble that developed today.

Actually, there are more than 300 electrical parts in even a small table model television receiver. Trouble in any one of them might cause the picture or sound to disappear or to be received poorly.

Take your automobile for instance. Tuning up the motor today is no guarantee against a tire blowout tomorrow!

Such a thing is easier to understand because most of us are more familiar with automobiles than with today's highly complicated TV and radio sets. But such unconnected troubles occur in TV and radio nevertheless—and because they are so

hard to explain in non-technical terms, it is always embarrassing to your service technician when they do.

His continued business existence is based on gaining the full confidence of you and other set owners like you. He isn't in business to "gyp" you or to overcharge you. His success is based on doing each and every job to the level best of his ability, at a fair price for his skilled labor. It's only when you patronize the shops that feature "bargains" at ridiculously low prices that you need worry. Good radio and TV service can't be bought on the bargain counter! Set owners who recognize this aren't likely to get "gypped."

Sincerely yours,

(HARRY KALKER, President)

SPRAGUE PRODUCTS COMPANY

(Distributors' Division of the Sprague Electric Company)

81 Marshall Street
 North Adams, Massachusetts



WORLD'S LARGEST MANUFACTURER OF ELECTRIC CONDENSERS

square feet of space. It is expected that the building will be completed by the middle of 1953.

LaPointe-Plascomold Corp., in another expansion move, transferred all facilities for the manufacture of Vee-D-X antennas and accessories from Windsor Locks to Rockville, Conn.

Amperex Electronic Corp. is now in full operation in its Hicksville, N. Y. plant according to an announcement by S. E. Norris, president. The new plant, which houses executive, clerical, research, engineering, and production facilities for electronic tubes, is part of the company's long range expansion program.

Telrex, Inc., Asbury Park, N. J., established a new Commercial and Amateur Array Department which is in full production on the company's 2-meter "Fishbone" and conical Ham Beams. 6-, 10-, 15-, and 20-meter arrays are scheduled for delivery at an early date.

National Video Corp. is consolidating operations of its four former plants under one roof in a new 115,000 square-foot plant in Chicago, according to an announcement by Asher J. Cole, president of the company. This move will permit the company to double its output of TV picture tubes.

Zenith Radio Corp., opened a new \$5,000,000 manufacturing plant in Chicago for the production of speakers, coils, transformers, and other radio and TV components, in addition to Zenith hearing aids and government defense materials.

Vaco Products Co., Chicago, manufacturers of "Amberyl" plastic-handle screwdrivers, opened a new branch in Dallas, Texas.

Snyder Manufacturing Co., Philadelphia, designed a new display board for its line of auto-radio antennas. Mounted on a heavy wood base and finished in red, blue, and green Day-Glo colors, the display is intended for counter use.

Production and Sales

The RTMA announced that 2,318,236 TV sets and 4,838,343 radios had been produced during the first six months of 1952. A breakdown of the radio production figure showed that 1,831,877 were home sets, 1,543,877 auto radios, 777,504 clock radios, and 685,085 portables.

The RTMA reported the sale of 247,724 TV picture tubes during May, 1952, compared with 229,250 for May, 1951. The Association further reported 23,636,484 receiving tubes sold during May compared with the May, 1951, figure of 34,074,356. Of the May, 1952, figure, 15,807,449 were sold for new equipment, 4,178,292 for renewals, and the balance for export and Government use.

The report pointed out that the present production of military and electronic communications equipment combined with the civilian output of radio and TV receivers exceeds the peak output of the industry during World War



TUBE AND TOOL CARRYING CASE
Holds 137 tubes — plus all regular tools.

FLASHING SERVICE DISPLAY
A 6-color display featuring your ability to "Clear Up The Picture."



PLEXIGLO ILLUMINATED SIGN
A bright and colorful service selling sign.

To help you increase your profits...
To help you work more efficiently...

RAYTHEON

has made these useful
NEW SALES AND SHOP AIDS
AVAILABLE TO YOU!



SHOP JACKETS and COATS
Expertly designed, sturdy, long wearing, comfortable garments. Full length or jacket style.

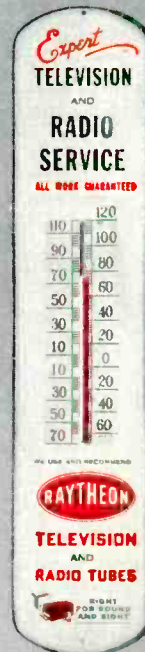

OUTDOOR THERMOMETER
A heavy gauge, jumbo size (8" x 39") outdoor unit.



SCOTCH TAPE AND DISPENSER
3/4" Scotch Acetate Tape bearing your name. Handy Dispenser.



POLITICAL WINDOW STREAMER
You can use this effectively from now 'til November.



ILLUMINATED TEST PATTERN CLOCK
A Telechron motored beauty.



Write for FREE BOOKLET!

It's chock full of these and many other useful shop aids and sales promotion items that are musts for every service dealer — imprinted stationery, job tags and record cards, ad mats, post cards, shipping labels, decals, etc. Some are free, others available at less than cost. Ask your Raytheon Tube Distributor for them or write for booklet to Department F



DISPLAYS
Colorful displays that sell your service.



RAYTHEON MANUFACTURING COMPANY

Receiving Tube Division
Newton, Mass., Chicago, Ill., Atlanta, Ga., Los Angeles, Calif.

Excellence in Electronics

RAYTHEON MAKES ALL THESE:
RECEIVING AND PICTURE TUBES • RELIABLE SUBMINIATURE AND MINIATURE TUBES • GERMANIUM DIODES AND TRANSISTORS • NUCLEONIC TUBES • MICROWAVE TUBES

MERIT

tv full-line*
components give
universal coverage

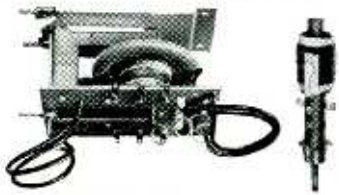

NEW IMPROVED HVO-7 FOR GREATER COVERAGE
Tapped AFC Winding. Covers Admiral Chassis 21-24 Series.

MWC-1 UNIVERSAL WIDTH COIL
(3-27 MH) A Tapped Secondary For AGC or AFC.



IF-RF COILS
Only complete line of TV replacements.



"COSINE" YOKES
Complete with leads & network.



MATCHED FOR DIRECT DRIVE
MDF-30 HVO-8
A-3080 Vert. Mtg.
A-3081 Horiz. Mtg.
Autoformer



KIT NO. 1000
MATCHED SET FOR SPEEDY PROFITABLE SERVICE!

MERIT . . . HQ for PRACTICAL TV Service Aids
MERIT'S 1952 Catalog No. 5211 with new MERIT IF-RF Coils.
Other MERIT service aids:
TV Repl Guide No. 404, 3500 models & chassis.
Cross Ref Data, IF-RF Coils, Form No. 14.
See your Jobber or write: Merit Coil and Transformer Corp., 4425 Clark Street, Chicago 40.



These three MERIT extras help you:
Exclusive: Tapemarked with specs and hook-up data.
Full technical data packed with every item.
Listed in Howard Sams Photo-facts.



*Merit is meeting the TV improvement, replacement and conversion demand with a line as complete as our advance information warrants!

II. The association noted that only 12 manufacturers of electronic equipment and parts failed during the past year, compared with 15 for the previous year. The general outlook for radio and TV was reported as most encouraging, and a rise in TV sales was predicted for 1953.

Business Briefs
... Allen B. Du Mont Laboratories Cathode-Ray Tube Division established a new warranty policy on replacement picture tubes which extends the coverage from six to twelve months from the date of installation in the consumer's set.

... Radio Craftmen, Inc., Chicago, has appointed authorized service centers in key cities under the direction of Bernard A. Menarik, field engineer. Those already established include: Winters' Radio Lab., New York City; Holbert Electronics, Seattle; Jack P. Plasmier, San Francisco; Los Angeles Radio & TV Maintenance, Los Angeles; and Western Communications, San Diego.

... CBS-Hytron Radio & Electronics, Danvers, Mass., has begun large-scale operations on semiconductor products. Germanium diodes are already in production. Point-contact type transistors are in the development stage, with production scheduled to begin this year, and will be followed later by junction transistors. The CBS-Hytron laboratory is doing research work on special semiconductor materials.

... The West Coast Electronic Manufacturers' Association has issued the fourth edition of its Directory which includes a complete alphabetical listing of corporate members with officers and a product index.

... Bulova Watch Co., New York City, made a licensing arrangement with Western Electric Co. for the development and production of transistors.

... NEDA will hold its Third Annual Convention and Manufacturers' Conference in Atlantic City, N. J. September 22 through 25. Hal F. Bersche, manager of renewal sales of the RCA Tube Department, will be one of the principal speakers in the educational program on u.h.f.

... Carbonneau Industries, Grand Rapids, Mich., manufacturer of radio and TV loudspeakers, celebrated its sixth anniversary at a party sponsored by employees and friends.

... The RTMA admitted six new members to the association bringing total membership to 340 member-companies. The new members are:— DeJur-Amsco Corp., New York City; Ellar Woodcraft Corp., New York City; Laidman Krispin Co., Chicago; Rego Electric Co., Hoboken, N. J.; Spencer-Kennedy Laboratories, Cambridge, Mass.; and Vacuum Tube Products, Oceanside, California.

—end—

INDISPENSABLE! PHOTOFACT BOOKS



Photofact Television Course. Covers TV principles, operation and practice. 216 pages; profusely illustrated; 8½ x 11". Order **TV-1** Only **\$3.00**

Television Antennas. New 2nd edition. Describes all TV antenna types; tells how to select, install, solve troubles. Saves time; helps you earn more. 200 pages; illustrated. Order **TAG-1** Only **\$2.00**

Television Tube Location Guide. Volume 2. Accurate diagrams show position and function of all tubes in hundreds of TV sets; helps you diagnose trouble without removing chassis. 224 pages; pocket-size. Order **TGL-2**. Only **\$2.00**

Television Tube Location Guide. Vol. 1. Over 200 pages of TV receiver tube position diagrams on hundreds of models. Order **TGL-1** Only **\$1.50**

Making Money in TV Servicing. Tested proved methods of operating a profitable TV service business. Covers all important phases. Authoritative, valuable guide to success. Over 130 pages. Order **MM-1** Only **\$1.25**

Servicing TV in the Customer's Home. Shows how to diagnose trouble using capacitor probe and VTVM. Short-cut methods help save time, earn more on outside service calls. Order **TC-1** Only **\$1.50**

1949-1950 Record Changer Manual. Vol. 3. Covers 44 models made in 1949, including multi-speed changers and wire and tape recorders. Original data based on actual analysis of equipment. 286 pages; 8½ x 11"; paper-bound. Order **CM-3** Only **\$3.00**

1948-1949 Changer Manual. Vol. 2. Covers 45 models made in 1948-49. Paper bound. Order **CM-2**. Only **\$4.95**

1947-1948 Changer Manual. Vol. 1. Covers 40 post-war models up to 1948. Order **CM-1** Only **\$3.95**

Recording & Reproduction of Sound. 2nd Edition. New, completely revised and vastly enlarged edition of the outstanding original volume. The most authoritative treatment of all phases of recording and amplification ever written. Over 800 pages. 6 x 9". Order **RR-2**. Only **\$7.95**



Audio Amplifiers. Vol. 3. Clear, uniform, accurate data on 50 important audio amplifiers, plus full coverage of 22 FM and AM tuners, produced during 1950. 362 pages, 8½ x 11". Order **AA-3** Only **\$3.95**

Audio Amplifiers. Vol. 2. A complete analysis of 104 well-known audio amplifiers and 12 tuners made 1949-50. 368 pages, 8½ x 11". Order **AA-2** Only **\$3.95**

Audio Amplifiers. Vol. 1. 102 amplifiers and FM tuners made through 1948. 352 p. Order **AA-1** Only **\$3.95**

Auto Radio Manual. Complete service data on more than 100 post-war auto radio models. Covers over 24 mfrs. 350 pages, 8½ x 11". Order **AR-1** Only **\$4.95**

Communications Receiver Manual. Complete analysis of 50 popular communications models. 246 pages, 8½ x 11". Order **CR-1** Only **\$3.00**

Radio Receiver Tube Placement Guide. Accurate diagrams show where to replace each tube in 5500 radio models, covering 1938-1947 receivers. 192 pages, pocket-size. Order **TP-1** Only **\$1.25**

Dial Card Stringing Guide. Vol. 2. Covers receivers made from 1947 through 1949. Shows you the one right way to string a dial card in thousands of models. Pocket-size. Order **DC-2** Only **\$1.00**

Dial Card Guide. Vol. 1. Covers sets produced 1938 through 1946. Order **DC-1** Only **\$1.00**

Order from your Parts Jobber or write direct to
HOWARD W. SAMS & CO., INC., 2201 E. 46th St., Indianapolis 5, Indiana
HOWARD W. SAMS & CO., INC.



Leonard C. Lane, B.S., M.A.
President of Radio-Television
Training Association,
Exec. Dir. of Pierce School
of Radio and Television

AMAZING NEW 2-FOR-1 OFFER

BE A LICENSED* TV TECHNICIAN

LICENSED TV MEN MAKE MORE MONEY

COMPARE RTTA'S EXTRA FEATURES

1. I furnish you ALL parts and equipment to build 15 big units, including your own COMPLETE TV RECEIVER. At the same time, I give you the training that will qualify YOU as a TV TECHNICIAN in America's booming TELEVISION & Electronics industries... *within months*, studying at home. Many of my students pay for their entire training from spare time earnings installing and servicing Radio-TV sets... start their own business.
2. Then—after you finish your training for a position as a full-fledged TV Technician... I help you qualify for the *better pay* BETTER JOBS that demand an FCC license, with my...

FREE*FCC COACHING COURSE

- Prepares you for your FCC License
- Included at NO EXTRA COST

The Best Jobs in TV & Radio Require an FCC License

ROUND TRIP TO NEW YORK CITY—FARE FREE!

Yes, I pay your way to New York and return from wherever you live in the U. S. or Canada, after you finish your home study course. I give you two free weeks—50 hours of advanced instruction and shop training at the *Pierce School of Radio & Television*. You use modern electronics equipment, including student-operated TV and Radio stations. You go behind the scenes of New York's big Radio-TV centers—to study first hand. And I give you all this AT NO EXTRA COST! (Applies to complete Radio-TV course only.)

GOING INTO UNIFORM?
Learn how you can qualify for military specialist ratings, and higher pay!

VETERANS!

Eligible under new G.I. Bill? Be sure to check coupon below!

MY GRADUATES HOLD GOOD PAYING JOBS

"Thanks to your training, I qualified for a good job as a Receiver Tester at Federal Telephone and Radio"
—Paul Frank Seier

"Your excellent instruction helped me get my present job as an airport radio mechanic for American Airlines."
—Eugene E. Basko

"I'm making good money in my own business, repairing and installing radio and TV sets — thanks to your training."
—Irwin Polansky

"I'll always be grateful to your training which helped me get my present fine position as Assistant Parts Manager"
—Norman Weston

RADIO-TELEVISION TRAINING ASSOCIATION

Approved as a Correspondence School under the laws of the State of New York
1629 Broadway, Radio City Station, New York City 19, N. Y.

YOU BUILD AND KEEP THIS LARGE SCREEN TV RECEIVER . . . included with my 15 big Radio-TV kits. Everything Furnished At No Extra Cost



NOW! Advanced FM-TV Training For Men Who Know Radio
Prepares You For Higher Pay Jobs In A Few Months
COMPLETE theory and practical training course . . . complete with kits including large screen TV receiver.
FCC License Coaching Course Included FREE.

MY SIMPLE METHODS MAKE SUCCESS EASY!

I have helped hundreds of men—most of them with NO PREVIOUS TRAINING—get ahead in TV. Even with a grammar school education, you can master my practical methods where you use actual parts and equipment and "learn by doing"

BIG MONEY IN TELEVISION FOR YOU

PREPARE NOW for the thousands of new job opportunities that will be available for you right in your home state, with lifting of government restrictions on new TV stations. As a well-trained technician, you can write your own ticket . . . get more success and happiness out of life. Don't delay. Mail the coupon today, and let my FREE BOOKS show you how easy it is.

NO SALESMAN WILL CALL!

Mr. Leonard C. Lane, President
RADIO-TELEVISION TRAINING ASS'N
1629 Broadway, Radio City Station
New York 19, N. Y. Dept. R-9

Dear Mr. Lane: Mail me your two new books about your amazing 2 for 1 offer with no obligation to me. I UNDERSTAND NO SALESMAN WILL CALL.

BOTH FREE! SEND NO MONEY! MAIL NOW FOR MY NEW FREE BOOKS!

NAME _____ Age _____

ADDRESS _____

CITY _____ ZONE _____ STATE _____

I am Interested In:
 Radio-TV Advanced FM-TV

VETERANS! If qualified under G.I. Bill, check here

EICO
TEST INSTRUMENTS

Guard

CBS-Columbia Inc.
HIGH STANDARDS OF
TELEVISION PRODUCTION QUALITY

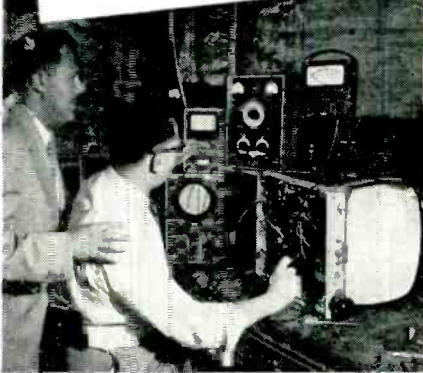

In the CBS-Columbia design laboratories, Al Goldberg takes some important readings with the EICO Model 221 Vacuum Tube Voltmeter and Model 555 Multimeter, as Harry R. Ashley looks on.



Mr. Al Goldberg, Assistant Chief Engineer of CBS-Columbia and Harry R. Ashley, President of EICO, inspecting the use of the EICO Model 221 Vacuum Tube Voltmeter and Model HVP-1 High Voltage Probe at the Sweep Frequency Troubleshooting Position on the CBS-Columbia Television production lines.



221K VTVM KIT \$25.95
WIRED \$49.95



HIGH VOLTAGE
PROBE \$6.95

KITS
WIRED INSTRUMENTS



NEW 565K MULTIMETER
KIT \$24.95 WIRED \$29.95
20,000 ohms/volt



320K SIG. GEN. KIT \$19.95 WIRED \$27.95

322K SIG. GEN. KIT \$23.95 WIRED \$34.95

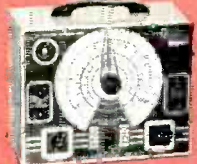

950K R-C BRIDGE & R-C COMP. KIT \$19.95
WIRED \$29.95



1040K BATTERY ELIM. KIT \$25.95, WIRED \$34.95

©1958 Electronic Instrument Co., Inc.
Prices 5% higher on West Coast. Due to unstable conditions, prices and specifications are subject to change without notice.

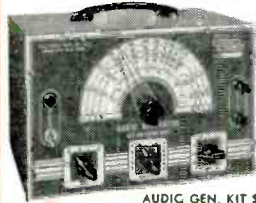

NEW 377K Sine & Square Wave
AUDIG. GEN. KIT \$31.95 WIRED \$49.95

For Laboratory Precision at Lowest Cost - the Leaders Look to EICO!

WHY does CBS-Columbia, Inc., one of America's great headline-makers in Television set production, use **EICO** Test Instruments on both its new Television production lines and in its design laboratories?

BECAUSE — like Emerson, Tele-King, Teletone, Majestic, and many another famous TV manufacturer coast to coast, CBS-Columbia knows that . . .

Only EICO Test Equipment delivers All 10 EICO nomical Features!

1. Laboratory Precision
2. Lowest Cost
3. Lifetime Dependability
4. Speedy Operation
5. Rugged Construction
6. Quality Components
7. Latest Engineering
8. Super-Simplified Assembly and Use Instructions
9. Laboratory-Styled Appearance
10. Exclusive EICO Make-Good Guarantee

Before You buy any higher-priced equipment, look at the EICO line—in *Wired and Kit form!* Each EICO product is jam-packed with unbelievable value. Compare, see **EICO instruments today**—in stock at your local jobber—and **SAVE!** Write **NOW** for **FREE** newest Catalog 9-C.

FOLLOW THE LEADERS
... INSIST ON EICO!

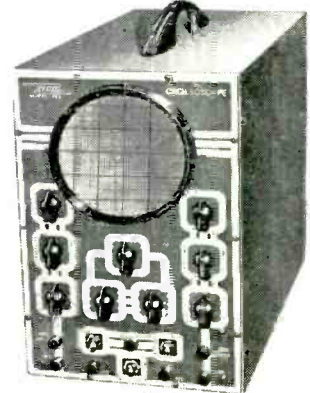

425K 5" PUSH-PULL SCOPE KIT \$44.95. WIRED \$79.95



NEW 21-K
VTVM KIT \$34.95
WIRED \$54.95
7 1/2" MEAS.



NEW 126K MULTI-METER KIT \$12.90
WIRED \$14.90
1000 ohms/volt

117K RES. DECADE BOX KIT \$7.95
WIRED \$24.95



315K DELUXE SIG. GEN. KIT \$39.95
WIRED \$59.95



145K SIG. TRACER KIT \$19.95
WIRED \$28.95



625K TUBE TESTER KIT \$34.95
WIRED \$49.95



360K SWEEP GEN. KIT \$34.95
WIRED \$49.95

NEW CRA PIX TUBE ADAPTOR for above \$4.50

EICO Reg. U. S. Pat. Off.

ELECTRONIC INSTRUMENT CO., Inc.
84 WITHERS STREET, BROOKLYN 11, NEW YORK

Status Of European Television

. . . *Why European Television lags behind* . . .

By HUGO GERNSBACH

SEVERAL months ago the writer visited France, Belgium, Switzerland and England for a five-week study of European radio, electronic and television conditions.

During our stay, we conferred with a number of radio-electronic leaders of the respective countries in order to gain a first-hand impression, particularly of television conditions.

In Paris we had been invited as the sole speaker before the *Syndicat National des Industries Radioelectriques*, the equivalent of our own RTMA—Radio-Television Manufacturers Association.

During our talk—and the subsequent period when the assembly of French engineers questioned us on various American TV and radio-electronic aspects—it was ascertained that in order to buy a TV set, the American skilled radio worker requires 3 weeks' labor to pay for a modern, medium-range price TV receiver (this was calculated at an average hourly rate of \$1.83 per hour, and a 40-hour week). The French engineers immediately pointed out that a parallel French worker requires a period of some 30 weeks' labor to pay for a comparative set. We noted later in England that British radio workers require about 10 to 13 weeks' labor to pay for a comparative TV receiver.

Without trying to oversimplify American versus European economics, we believe that our study points to the reason why in the U.S. we have today 18,000,000 TV receivers against England's 1,500,000, France's 18,000, and Switzerland's only a few thousand.

While inspecting several representative European TV and radio factories, and talking with a number of manufacturers, it soon became plain that:

(1) The European radio worker is first, and foremost an artisan. Hand work still leads—fast, machine mass-production in many instances is frowned upon by manufacturers who (a) can't afford to fully mechanize their plants, (b) are afraid of mass strikes by the workers who think that mechanization would throw too many out of work. Therefore, while the European worker's wages are from 2 to 5 times less than those of the comparative American worker, the time to turn out a European TV set, due to slow hand work, nevertheless is many times that of an equivalent American set.

(2) Post-war European taxes are so high and so involved that even with full mechanization, it is doubtful that, even in the foreseeable future, the European worker could ever buy a TV set with 3-weeks' wages, or even 6.

Hence TV progress in continental Europe, as far as mass penetration of TV sets into the population is concerned, seems very remote.

As to the technical picture quality, European TV in general is not far behind our own. With no commercials on European TV, the program quality is often better than ours—programs are usually much better and longer rehearsed, unhurried, and consequently the finished product on the screen is often more relaxing to the viewer.

Yet—TV being mostly government-owned—the European

programs are often overlong and frequently lag badly. Furthermore, each country broadcasts on a single frequency so there is naturally no choice of programs at a given moment—either you like what is presented at the time, or tune in later to view a program you think will be more to your liking.

In Europe, the television standards are different from our own. Where we have 525 lines and 60 fields per second, in France they have 441/819 lines and 50 fields, while in England the standard is 405 lines and 50 fields. In France, the French government—which owns all radio and TV transmitters—has so far not been able to allot sufficient funds, and in consequence the progress has been slow. While the quality of the French TV emissions are not much behind our own, hardly any money at all has been spent on studio equipment or programs. These conditions are now about 10 years behind the times, while at the main studio, if such it can be called, there are no modern facilities whatsoever for the performers. This probably will be remedied as the French economic conditions improve.

On the other hand, the quality of the British film broadcasts far exceeds our own today. The technicians of the corporation which operates all radio and TV transmitters, have evolved excellent means of high-fidelity film propagation, so much so that *their film broadcasts now far exceed in quality their live ones!* As one of the chief technicians of the BBC (British Broadcasting Corporation) put it to us, "We are now trying very hard to make our live broadcasts as good as our filmed ones."

This to an American technician sounds incredible, for in the U.S. exactly the opposite conditions prevail. The reason for this progress is that the English technicians have evolved a very high standard of technical perfection and know-how in all their film transmissions. American TV broadcasters would do well to inform themselves of the English progress in this sphere, because as everyone knows, most of our film broadcasts are exceedingly poor.

July 8th also marked the first historical exchange of European two-way international TV broadcasts. France and Britain now exchange daily TV programs routinely. At the point of origin, announcers who must speak both English and French perfectly, explain the features presented so that listeners in both countries can follow the various programs without difficulty. As television standards in France and England differ greatly, it would not be feasible to broadcast and receive the two countries' programs *directly*. A French TV set could not *directly* receive a British program, or *vice versa*—the result would be a blur on the screen.

The problem was solved as follows: When the French picture arrives on the London BBC special picture tube, a British television camera placed in front of it, simply views the incoming picture on that tube, *then* broadcasts it over the BBC transmitter. In this process, less than 2% is lost in quality.

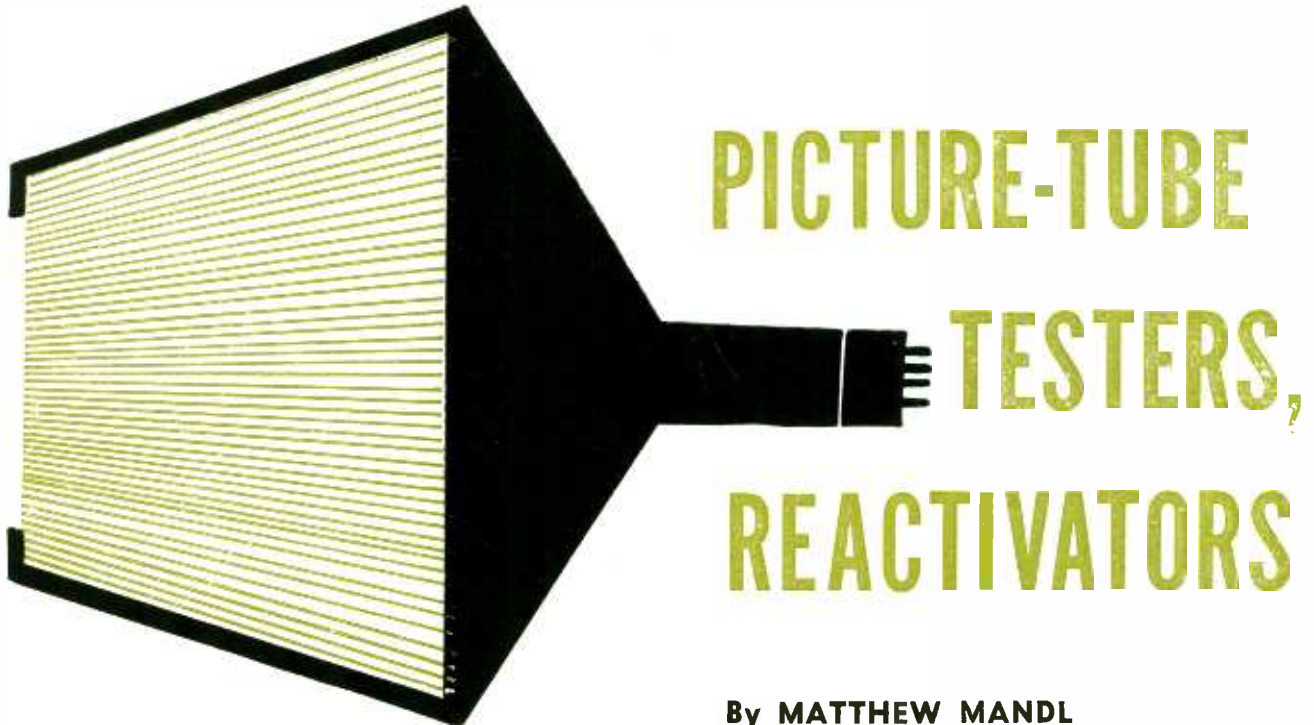

THE television service technician needs some means of checking picture tubes in order to avoid costly mistakes. He cannot always rely on the symptoms that appear on the screen. What appears to be the effect of a bad picture tube may actually be caused by a faulty circuit elsewhere.

A negative picture, for instance,

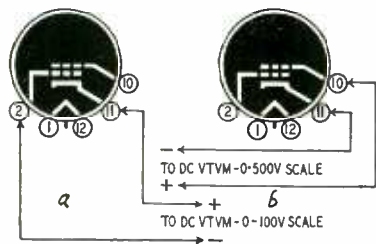

Fig. 1—(a) Connections for measuring picture-tube grid bias. Voltage should increase smoothly as brightness control is turned from maximum to minimum. Note meter polarities. (b) Checking accelerator-grid voltage. See text for value.

often indicates a defective picture tube. It could also be caused by excessive signal, interference from another receiver, a faulty a.g.c. system, or other troubles in the picture stages. A washed-out picture which lacks brilliancy may be caused by a bad picture tube, but power-supply trouble or incorrect grid-cathode voltage relationships can produce the same effects.

On the other hand, a bad picture tube may imitate brilliancy-control troubles, degeneration in video amplifier stages, or defects in the contrast-control and a.g.c. circuits.

No wonder the technician is apprehensive about diagnosing a particular defect as a poor picture tube. An error in diagnosis would mean consid-

erable trouble in removing the old tube and installing a new one. If the new tube does not help, additional measures still have to be taken after replacing the old picture tube.

Static tests

Generally speaking, two types of tests can be used to find out if the picture tube is to blame. One is the static test. Remove the picture-tube socket and test for the presence of the various voltages. If the tube does not light, measure the a.c. voltage across the heater pins (1 and 12 on modern *electromagnetic* tubes). With the v.t.v.m. on a d.c. scale, take a reading between the cathode and control-grid pins as shown in Fig. 1-a. The grid pin should show a negative voltage ranging from a few volts to over 60 volts when the brilliancy control is turned from maximum to minimum.

Next, measure the voltage at the accelerator-grid socket terminal as shown in Fig. 1-b. This should be about +250

volts for most 12- and 14-inch tubes. With larger tubes 300 volts or more would be normal. Use a scope to check the presence and amplitude of the composite video signal, because insufficient signal contributes to poor contrast and washed-out pictures. Set the scope sweep frequency at 30 cycles and connect the vertical input leads to pin 2 and pin 11 of the picture-tube socket. You should see the type picture screen shown in Fig. 2. With a calibrated voltage you can read the peak-to-peak voltage as well as observe the waveform.

The Pix-eye

This type of static test can be made quickly with commercial units like the "Pix-eye" shown in Fig. 3. One end is fitted with a standard diheptal tube base, which plugs into the picture-tube socket. The twin-beam electron-ray indicator at the other end shows whether normal operating voltages and composite video signals are present. Normal heater voltage lights the filament

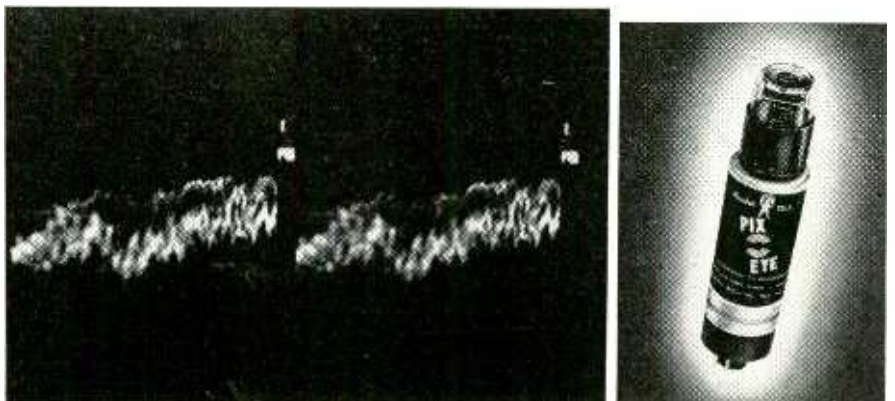

Fig. 2 (left)—Video waveform at grid or cathode pin of picture-tube socket. Scope sweep 30 cycles. Fig. 3 (right)—"Pix-Eye" socket-voltage and signal checker.

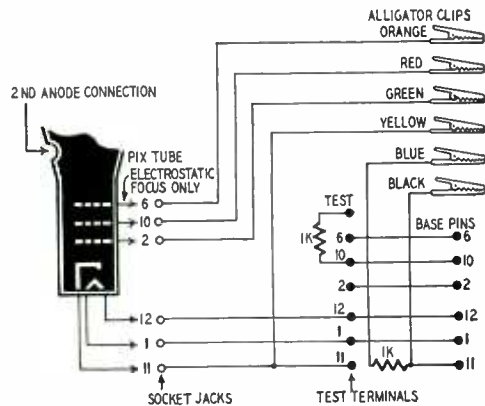

Fig. 5—EBCO Dynamic Analyzer circuit.

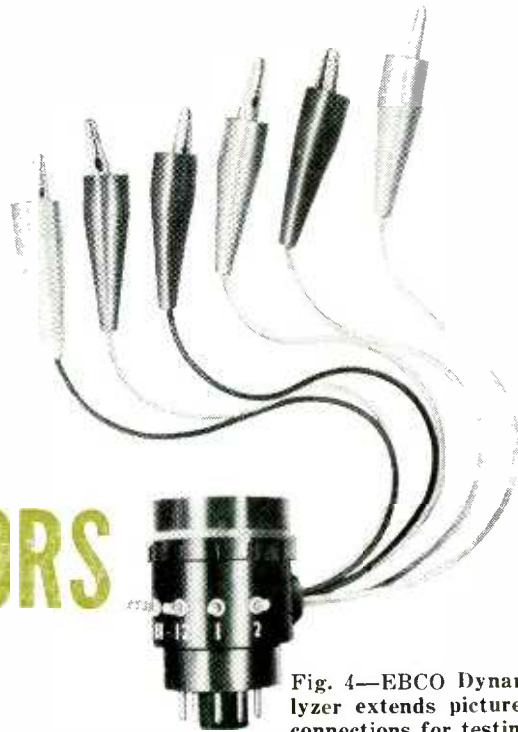

Fig. 4—EBCO Dynamic Analyzer extends picture-tube base connections for testing under normal operating conditions.

and REJUVENATORS

to a steady glow; the fluorescent screen glows if the accelerator voltage (pin 10) is O.K.; One beam should vary in area as the brightness control is rotated. With a signal coming through the receiver, varying the contrast control should change the area of the other beam. Video modulation is seen as a fuzzy border on the beam.

With the socket off, check at the picture-tube base pins for filament continuity, and shorts or leakage between tube elements.

The only sure method of checking the high voltage is to measure it. Drawing an arc by holding the terminal near the chassis is not an accurate way to find out how much voltage you have. Often a healthy spark can be obtained with only 9,000 volts, when the voltage actually should be 12,000 or 14,000 volts for best results with the picture tube in use.

Drawing an arc to the chassis will overload the high-voltage rectifier, decrease its emission, and shorten its useful life. If a spark test must be made, do it at the high-voltage receptacle on the picture tube. Here, at least, you are creating an arc at the point where the voltage would normally be applied.

The foregoing procedures are based on the process of elimination. If all tests show normal operating potentials and no shorts or leakages, then the picture tube is probably defective.

Dynamic tests

Static tests may not always tell the whole story because the picture tube is not operating under normal conditions. Sometimes faults will show up only when the tube is connected and voltages are applied. Testing the tube under actual operating conditions is known as

“dynamic” testing and there are several commercial models available to facilitate the process.

EBCO Dynamic analyzer

One unit for testing picture tubes under actual operating conditions is the EBCO dynamic analyzer shown in Fig. 4. It is used with a v.t.v.m. to test interelectrode voltages under load as well as to check emission characteristics in relation to cutoff and the accelerating electrode. It also locates open elements and measures leakage between tube elements.

To use the device, remove the picture-tube socket and install the dynamic analyzer between the tube base and the

socket. With the receiver on, voltages and waveforms can be checked at the terminals and alligator clips. The instruction manual for the device gives detailed examples of tests to be made and furnishes several charts to facilitate checks. The schematic for this device is shown in Fig. 5.

The NU Videotron

The National Union Videotron picture-tube checker is shown in Fig. 6. A neon bulb shows shorts and open elements. Peak beam current (proportional to light output) is measured on a bridge, with the neon bulb as a balance indicator. The condition of the tube is read directly from the scale of the bal-



Fig. 6—National Union Videotron picture tube checker locates internal defects and shows useful light output.

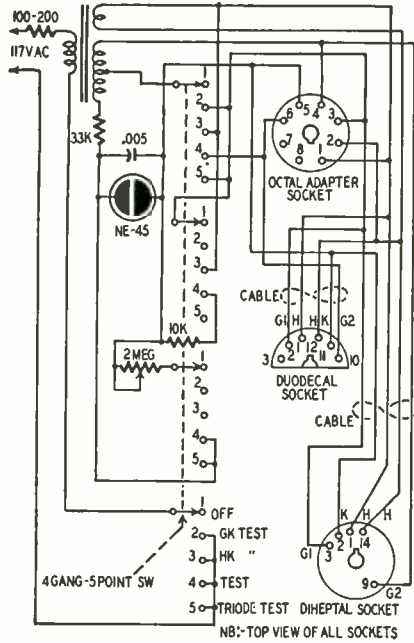

Fig. 7—Circuit of the Videotron tester.

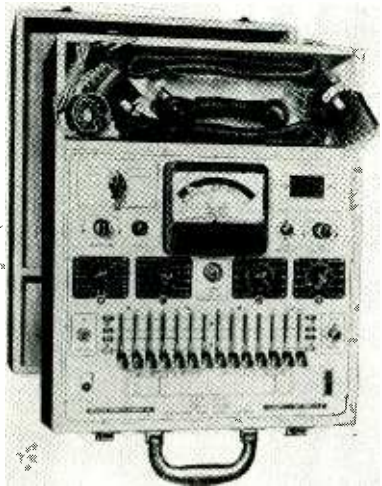

Fig. 8—Precision model CR-30 checks all cathode-ray and picture-tube types.

ancing control. The Videotron checks all electrostatic and magnetic-deflection picture tubes, with either magnetic or electrostatic focus.

Test sockets are provided for picture tubes with diheptal and duodecal bases. These are the types used on over 95 percent of modern tubes. An octal socket is provided on the panel so adapters can be plugged in for tubes with other bases. All tubes can be checked in their original cartons or in the receiver. The schematic of the checker is shown in Fig. 7.

Precision cathode-ray tube tester

A more elaborate and versatile tester is shown in Fig. 8. This device tests not only picture tubes but scope tubes as well. This is the series CR-30 cathode-ray tube tester manufactured by Precision Apparatus Company. It checks tubes by the principle that screen brightness is proportional to beam cur-

rent. It also checks accelerating-anode and deflection-plate elements. It tests all modern cathode ray tubes, regardless of application.

The basic indicating device is a voltage-regulated and calibrated v.t.-v.m., with a special scale indicating picture-tube quality. A heavy-duty potentiometer is used for precise line-voltage adjustments.

The device locates leakage paths or shorts in the gun structure with a high degree of sensitivity. The actual leakage path is indicated by an RTMA-numbered, 14-element selector system. Open-filament tests are also included in the leakage and short test indications.

The tester measures the electron beam current and checks the critical central-emission area of the cathode. The controlling action of the first grid is also ascertained. Accelerating anodes, deflection plates, and other elements not directly concerned with beam current are tested separately.

The schematic of the CR-30 is shown in Fig. 9. Individual calibrating controls are adjusted and sealed at the factory. The meter circuit cannot be damaged by overloads which might result from picture-tube defects. The entire circuit is fused for protection against shorts.

Reactivators and brighteners

Picture tubes are often discarded for insufficient brightness. If this is caused by low cathode emission rather than defects in gun or screen material, the tube often can be rejuvenated or re-activated.

The cathode is a nickel cylinder to which an emitting element—either strontium oxide or barium oxide—is fused. Through abuse, gas content, or old age, the emission drops below normal and the brilliancy is reduced.

Rejuvenation subjects the tube to the same process used in its manufacture. The filament voltage is raised above normal while low potentials are applied to the gun elements.

Emission current is measured, and when it has reached a leveling-off value the heater voltage is reduced to normal. The heater is "aged" at this voltage for a short time with no voltages applied to the gun structure. After this, the emission characteristics are checked again at several different gun voltages to see if potential changes give proportional emission changes. If they do, the cathode has been decontaminated and its emission restored.

Tubes with low emission also can be operated at slightly higher-than-normal voltages for increased brilliancy. De-

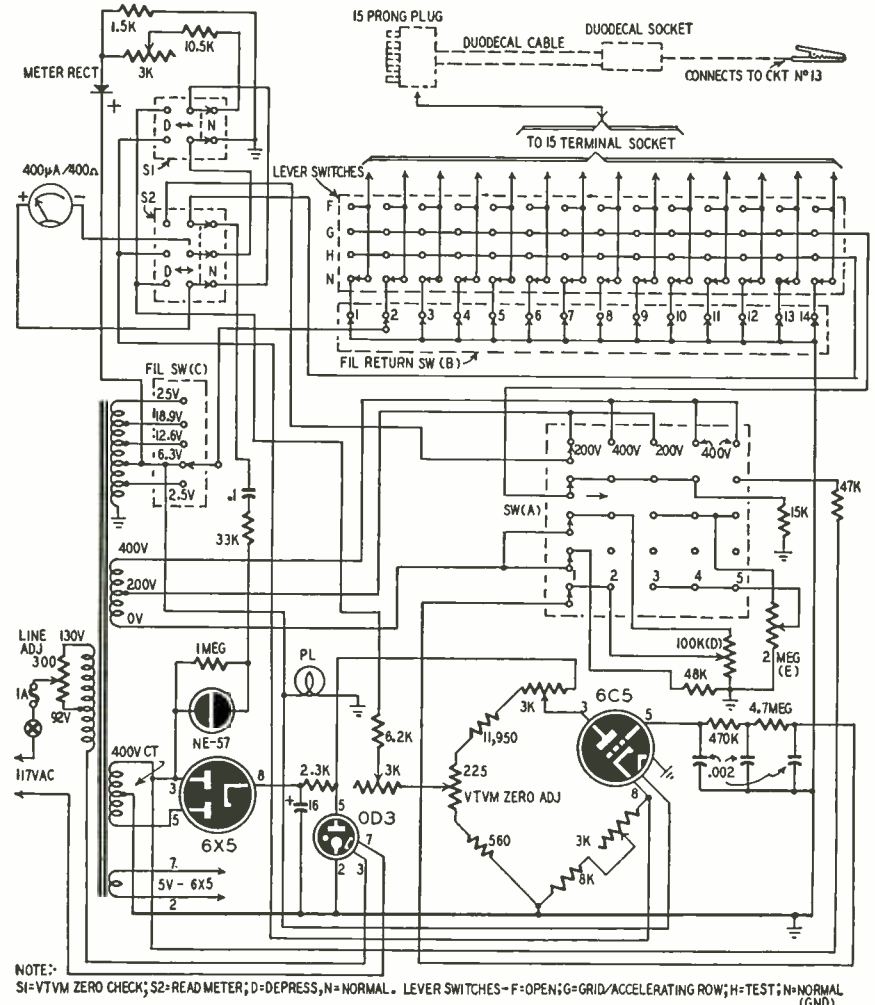

Fig. 9—Schematic of the Precision CR-30 picture-tube tester. Tube quality is indicated directly in terms of brightness. Adapters are available for other bases.



Fig. 10—Perma-Power "Britener" reactivates cathode by raising heater voltage.

ices which do this are called "brighteners." These also help in areas where the line voltage is below normal and drops the voltage on the picture-tube filament below the rated value.

The Perma-Power Britener

One commercial product for restoring brightness in this way is the Perma-Power TV-Tube "Britener" shown in Fig. 10. This unit also isolates the filament circuit of the picture tube from the receiver power supply and will thus relieve some cathode-filament shorts.

The Perma-Power Britener is for tubes with duodecal bases. Installation consists of removing the socket from the picture tube and plugging the Britener base unit into it. The socket provided with the Britener is then placed on the picture tube. The unit plugs into the a.c. line and is controlled by the receiver on-off switch through an internal thermal contactor.

The unit contains a tapped transformer and a switch for selecting any one of three higher-than-normal heater voltages. The leads which formerly went to the picture-tube heater are shunted by a resistor so the device can be used in either series or parallel filament circuits.

The voltage is boosted by the No. 1 or No. 2 position of the switch, according to the degree of rejuvenation needed. Depending on the condition of the tube, brightness may be restored for a period of several months to a year. When the picture becomes dull again, use the third position of the selector. Final loss of brilliancy in this position means a new tube is definitely needed.

The unit can be installed inside or outside the cabinet, and can be used over again in any other installation.

Stay-Brite TV-tube saver

This device (Fig. 11) is similar to the one described above in providing three successively higher boost voltages for the picture-tube heater, as well as a normal position. In addition, it has a low switch position which applies reduced heater voltage, and may be used

to prolong the life of new picture tubes, or where the line voltage is abnormally high. Power is obtained directly from the picture-tube socket of the receiver, eliminating the need for any additional external wiring. Like the previous type, it may be installed permanently in any a.c.-operated receiver using a duodecal-based picture tube, or removed and used elsewhere as required.

The Crest Labs rejuvenator

Another rejuvenator which can be used in the same way is shown in Fig. 12. This one is manufactured by Crest Laboratories. It has a fixed output slightly higher than the normal voltage for the picture tube heater. It is also installed in the receiver cabinet. The base of the brightener is attached to



Fig. 11—"Stay-Brite" picture-tube reactivator has 5 heater-voltage positions.

the picture tube socket, while the brightener socket goes to the picture tube base. When it has outlived its usefulness, it can be used again on other receivers.

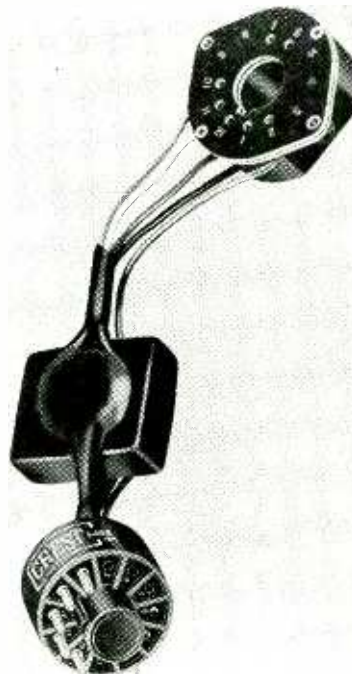

Fig. 12—Crest Labs' heater-boost rejuvenator needs no a.c.-line connection.

Tubes with diheptal (14-pin) or other bases can be rejuvenated in the same way with some additional wiring. Disconnect *only the heater leads* from the receiver picture-tube socket and solder a spare socket contact to the end of each lead. These contacts can then be slipped over pins 1 and 12 of the rejuvenator plug. Two new heater leads are then soldered to the receiver socket terminals with phone tips at the open ends. The phone tips are then inserted in terminals 1 and 12 of the rejuvenator socket. Be sure to check if one side of the heater is grounded or connected to the picture-tube cathode, and make the interconnections follow the same arrangement.

Don't attempt this on a Philco model 48-700, or any other receiver in which the picture-tube heater or cathode is more than about 150 volts above or below ground potential.

Tester-reactivators

Several companies furnish units which serve as both picture-tube testers and reactivators. The one manufactured by Transvision is shown in Fig. 13. A similar model is also manufactured by the Electronic Beam Corp. who make the EBCO dynamic analyzer shown in Fig. 4. These units check picture tubes by measuring cathode emission, locating shorts between elements, and indicating high-resistance leaks up to 3 megohms.

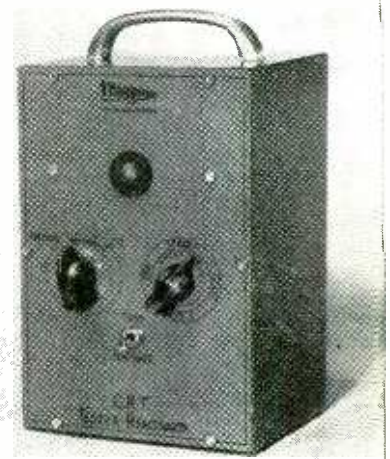

Fig. 13—Transvision tester-reactivator.

Tubes with low light output can be rejuvenated without removing them from the set. A neon bulb indicates when the reactivating process is completed.

None of these rejuvenating devices will be effective if there are internal shorts, damaged screen material, or other defects in the tube. Check the tube first for these defects. If the only trouble is low cathode emission, try rejuvenation to increase the useful life.

Many other makes of picture-tube reactivators and testers are available now and new ones are constantly appearing on the market. The fact that they are not described or mentioned individually is due only to space limitations.

—end—

Why you get it and what to do about . . .

EYESTRAIN

FROM

TV



By **GEORGE E. ROW**

THE next time a customer complains of eye-strain from watching television, give him the following instructions:

1. Turn on more lights in the room while you watch TV.
2. Reduce the brightness setting of the receiver.
3. Move farther away from the picture—and look away from it frequently.
4. Adjust the focus for greater line thickness.
5. Reduce the height of the picture.

To understand eye-strain from TV one must first understand the mechanism of vision. The eye is a camera which focuses an image of the scene being viewed on a light-sensitive mosaic covering its rear inside surface. Each element of this mosaic reports to the mind the amount and nature of the light falling on it. The interpretation which the mind places on the whole mass of reports coming to it from the individual elements constitutes *vision*. The elements are very small—as indicated in Fig. 1. An individual element receives the light coming from a square measuring one thirty-second of an inch on a side held at a distance of 10 feet. The individual elements function best when the quantity of light reaching them in a given time is held within certain limits. To hold the light within these limits the eye is equipped with an

iris which opens and closes automatically as the *average* brightness of the scene varies. Now, if by some trick we expose the mosaic to light three or four times stronger than the average for which the iris adjusts itself—we should expect eye-strain to result. This is exactly what happens in watching TV.

The face of the picture tube is covered by a phosphor which glows while being bombarded by the beam current and continues to glow even after the bombardment has ceased. Fig. 2 shows how the light from a spot on the screen decays. The *average* brilliance is approximately 27 percent of the maximum. The iris of the eye adjusts to the *average brilliance*, but the individual elements of the mosaic will be bombarded by the *maximum* value of the light, which is over three times the average. This causes the strain—a condition which nature never anticipated. This high ratio of maximum brilliance

maximum to average brightness in the scene being viewed.

Third, move farther away from the receiver. Here we are bringing into play another principle. In describing the eye we pointed out that the light-sensitive elements are of finite size. If one sits ten feet from a screen fourteen inches in height, then the individual lines of the picture will correspond to individual light-sensitive elements of the eye—as shown in Fig. 3-a. Since the whole picture is scanned in a thirtieth of a second, the elements of the eye are bombarded with the maximum value of the light some thirty times a second. Now move back to a distance of twenty feet—as indicated in Fig. 3-b. Then the individual element of the eye corresponds to a pair of lines in the picture. With interlaced scanning, each line will be scanned sixty times a second. The elements of the eye are bombarded with the maximum value of

Defocusing until the blank space disappears will bring the eye back to a 27 percent adjustment. (Careful adjustment of the vertical hold control for better interlace helps, too.—*Editor*)

Fifth, reduce the height of the picture. This accomplishes the same result as the defocusing—but it may leave some black strips at the bottom and top of the tube. My experience has been that the customer usually objects to this. About the best that can be done is to advise customers owning old-style Zeniths with round screens to operate them at reduced height setting.

A lot depends on the customer—both as to what you can do to reduce the irritation and as to just how much irritation is produced. Some people can watch TV by the hour. As for myself, after fifteen minutes I'm ready to give it the boot. Apparently some of us can stand a greater ratio of maximum to average brilliance than others. In some

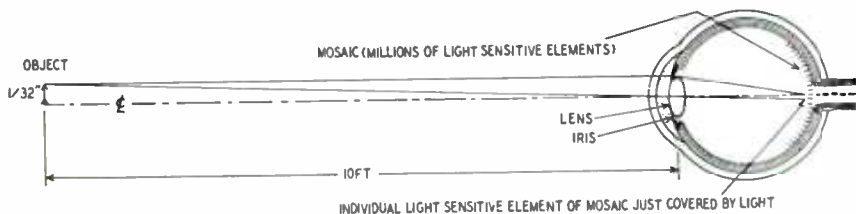

Fig. 1—Each sensitive element of the mosaic receives light from a tiny area.

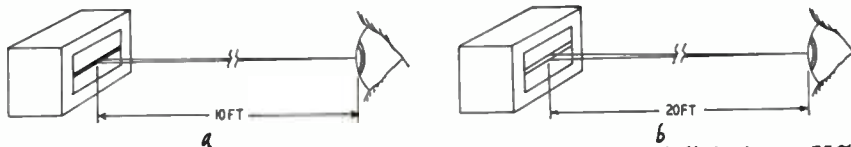

Fig. 3—At double distance each element sees two lines but peak light is cut 75%.

to average brilliance may be verified experimentally. Stand about twenty feet from an operating receiver and look at a point a foot or so directly above the screen. Then whip the eyes to a point about two feet below the screen, observing what you see on the screen during the transit. (It may be necessary to repeat this several times. Blinking the eyes at the time the move is made will help.) You should see an exceedingly brilliant horizontal bar comprising about a dozen scanning lines. Depending upon the exact instant at which the eyes are moved, the bar will appear at the top, in the center, or at the bottom of the screen.

Understanding the problem will help us find a solution. Boiling it down to a principle it is this: Anything that will reduce the ratio of *maximum* brilliance to *average* brilliance of the scene being viewed will relieve the eye-strain. Since the viewer sees more than just the TV screen, there are several things we can do. First, turn on some more lights in the room. This will brighten the background of the TV picture. The iris of the eye will contract, and the maximum brilliance of the TV screen will have less effect on the eye. (Sylvania has taken advantage of this device in its "Halolight.")

Second, reduce the brightness setting of the receiver. This works from the other direction to reduce the ratio of

the light twice as often. We have doubled the average brilliance of the screen without increasing the maximum brilliance. This has been done at the expense of picture detail—which has been reduced 75 percent by doubling the distance. But if we have a picture which we can watch comfortably—which we couldn't before—then we have gained. Moving back also decreases the irritation of the eye. Although the benefit to be realized from moving back is based on scientific principle, some psychological factors play a part. Moving back tends to make the viewer look away from the screen more often—freeing the elements of the eye momentarily from that whacking they take thirty times a second.

Fourth, adjust the focus so that the lines of the picture blend into one another. This reduces eye-strain but at the expense of picture detail. The effect is quite marked up to the point where the unscanned space between the raster lines is completely eliminated. Little is to be gained thereafter. The principle is not too difficult to understand. Suppose the unscanned space between the raster lines is equal in width to the lines themselves. Then the eye in adjusting to the average brilliance of the scene will adjust to a level only 13.5 percent of the maximum brilliance. The ratio of maximum to minimum brilliance is made approximately 7 to 1.

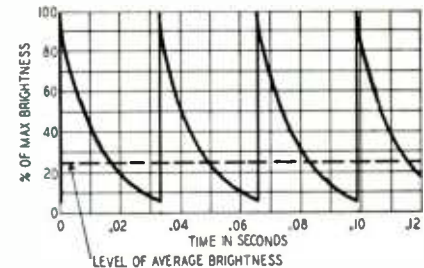

Fig. 2—How light from the fluorescent screen of the picture tube decays after each scanning cycle of the electron beam. The decay follows an exponential curve.

cases perhaps you can dig up a projection set for the customer. It seems to me that the persistence of these screens—or perhaps it is because they are operated at greater brilliance—is greater than that of direct-view tubes. Anyway, the old phrase, "I can watch a projection set, but these little sets hurt my eyes," is frequently heard. Maybe it is because the darned things can't be kept in focus.

I have given you some tricks to reduce eye-strain. In the main, the tricks reduce the detail in the picture. The complete elimination of eye-strain is an engineering problem. What we need is a storage principle in kinescopes similar to that utilized in iconoscopes. Then a spot on the TV screen would glow with constant brilliance from one scan to the next and then instantly take on a new value of brilliance—which it would hold until the next scan. The ratio of maximum to average brilliance in the scene would then be reduced to unity—for which nature equipped our eyes. If that cannot be provided, then perhaps a phosphor may be developed which will decay along a cosine curve—rather than along the logarithmic curve. These are the only possibilities I see at present—and they are pretty far-fetched. Until the engineers come forward with a solution, use any of the tricks I have given you that will satisfy the customer.

—end—

the last word on

CONVERSION

The author concludes the discussion by pointing out more little-known conversion facts

By **M. HARVEY GERNSBACK**

Editorial Director

PART II

LAST month we discussed the changes that were necessary in the horizontal sweep circuits of an RCA 8T244 to convert it for use with a 17TP4. Before going into the changes needed in the vertical circuits, let's discuss some of the other problems that can come up in the horizontal circuits when doing a conversion. We talked about drive and its effect on circuit performance. This a good place to bring up a point not covered last month: If the converted 8T244 receiver is to be operated in an area where the line voltage is below 115, it may be necessary to reduce the size of the series screen resistor R186 below its original value of 6,800 ohms to increase the width and high voltage. But don't reduce it enough to exceed the maximum screen-input rating of the 6BG6-G.

Sometimes there may be enough high voltage and drive, but not enough width. What then? The classical "quick and dirty" remedy (known to all technicians who have done conversion work) is to shunt a small capacitor across two of the secondary taps on the output transformer (usually across the taps recommended for connection of an inductive width control). This will increase the width all right. For example, in this conversion a .005- μ f capacitor across taps 5-7 of the RCA 231T1 flyback transformer increased the width about 10 to 15%. But—it had its price. The high voltage dropped about 600 volts, which was not too important, since we had plenty. But, much more important is the effect of the added capacitance on retrace time.

Any time you add capacitance, you increase retrace time (flyback time) because you lower the natural resonant frequency of the circuit—and that can cause foldover troubles. Horizontal foldover (on the left side of the screen) has probably caused more grief in conversion work than any other trouble. Yet the remedy is quite simple, provided the original design of the flyback transformer included adequately short retrace time. The converting technician

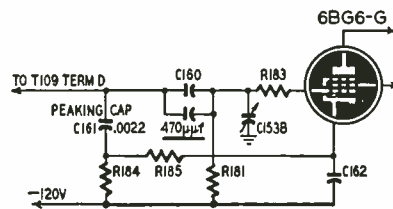

Fig. 1—Peaking circuit in RCA 8T244.

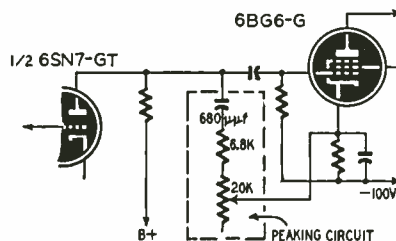

Fig. 2—Horizontal peaking in 630 sets.

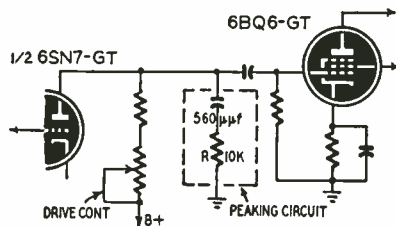

Fig. 3—Drive control affects peaking.

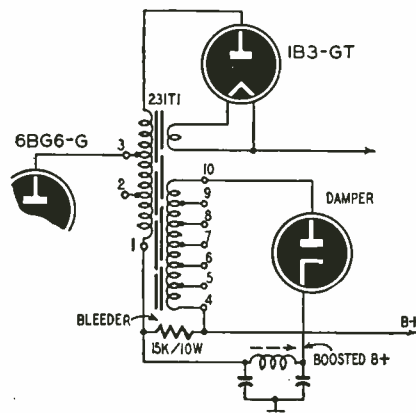

Fig. 4—Added bleeder increases drain on boosted B plus for better linearity.

must keep shunt capacitances as low as possible in the flyback circuit.

Another important consideration is that the flyback transformer and the deflection yoke are properly matched to each other, and that the distributed capacitance of the yoke is not excessive. Adding capacitance across the flyback transformer to increase width is a sure way to invite foldover trouble. Points to watch with extra caution for excessive capacitances to ground are the plate lead to the high-voltage rectifier, and the hot end of the deflection-secondary winding.

If we can't increase width by adding capacitance, what are we to do? One simple trick is to *reduce* the size of the blocking capacitor in series with the horizontal yoke winding (0.1 μ f in Fig. 1 of last month's article), if this is used. (The value used in this conversion provided greatest width. Increasing this capacitance to 0.5 μ f or higher will *reduce* width.)

These changes affect width without adversely affecting retrace. Another point affecting width (and drive and high voltage too) is the value of the horizontal peaking capacitor or resistor-capacitor combination in some sets. Fig. 1 shows the location of the peaking capacitor in the 8T244; Fig. 2 shows the R-C peaking circuit in the familiar 630 chassis. In this circuit the R element is a fixed resistor and a potentiometer used as drive control. It is not

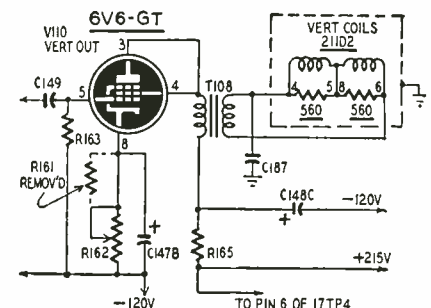

Fig. 5—Removing or shorting R161 gives more range to vertical linearity control.

a true drive control but rather a peaking control. Many other sets use a similar circuit but with fixed values for R and C. In these the drive control is a separate variable capacitor across the horizontal output-tube grid, or a variable resistor in the plate circuit of the horizontal oscillator or discharge tube. See Fig. 3.

Where a circuit similar to Fig. 1 or Fig. 3 is used, it is possible to get maximum peaking (with its attendant increased drive, width, and high voltage) by carefully adjusting the value of C161 (in Fig. 1) or of R (in Fig. 3). Replace R with a potentiometer and adjust for maximum high-voltage output. Measure the value of the potentiometer at peak setting and replace with a fixed resistor close to the measured value. In a circuit such as Fig. 1 try different values of C161 smaller and larger than the original capacitor. Small changes can have a large effect. A capacitor

sacrifice for reduced foldover. Any of the methods described previously can be used to increase width in cases of this kind.

Horizontal linearity

Another common conversion problem is poor horizontal linearity. The usual sources of trouble on the right side of the picture are: wrong-value linearity coil for the new flyback, wrong-value or defective capacitors associated with the linearity coil. One frequent cause of poor linearity is seldom mentioned. That is the amount of current drawn from the boosted B plus output of the damper tube (over and above that drawn by the horizontal output tube). Every flyback transformer is designed to supply a certain amount of boost current. If the drain isn't near the recommended design value, linearity will suffer, particularly near the right edge of the picture. The

larges and goes out of focus as the brightness control is advanced. At the same time brightness decreases. Blooming may occur at normal viewing brilliance, making good reception impossible. This trouble is caused by poor regulation of the high-voltage supply as the picture-tube beam current is varied by adjustment of the brightness control.

Several things can cause blooming. (Assuming, of course, that the receiver was checked *before* conversion and placed in A-1 condition, with weak tubes replaced and defects corrected as recommended in part I of this article. It's also assumed that drive has been properly adjusted and peaking is optimum; in short, the set works fine except for blooming.) First of all is a defective picture tube. A gassy tube will draw excessive cathode current. A good rule of thumb is that a normal tube, at normal brightness, will draw a cathode current of 100 to 140 μ a. This holds true for most direct-view tubes, *provided* the tubes are operated with normal second-anode and screen voltages for the tube size. (For example, 10,000 and 250 volts for a 10-inch tube; 15,000 and 350 volts for a 17-inch tube; 16,000 and 400 volts for a 21-inch tube). This also assumes that the ion-trap magnet has the proper strength and is properly adjusted and that the beam is correctly centered. The best remedy for a gassy tube is replacement. However in conversion problems we're usually dealing with brand new tubes, so this problem is relatively uncommon.

Suppose we check our tube and find it is normal and that the ion-trap magnet is properly adjusted—but we have blooming. Measure the high voltage at the picture-tube anode, first with the tube face dark (brightness control off), then with the brightness control advanced to normal picture brightness. The high voltage should not vary more than about 5 to 10%. If it does, the yoke is probably improperly matched to the flyback transformer. If the flyback does not have a tapped secondary it may be impossible to improve the situation without replacing the yoke. The new RCA 231T1 with its 7 secondary taps will match any yoke with a horizontal-winding inductance from 8 to 30 mh. Instructions are supplied with the transformer for selecting the proper tap for a given yoke inductance.

If the yoke inductance is unknown you'll have to try various tap arrangements to find the best match. As a rough guide, 50- to 53-degree yokes have an inductance of about 8-10 mh. 66- to 70-degree yokes range from 10 to 18 mh. Direct-drive system yokes usually run about 28 mh. With a proper match, blooming should be negligible at normal picture brightness.

Three final points on horizontal sweep circuits: First, the power-transformer filament winding for the damper tube should have adequate insulation for the higher peak voltages developed in conversion. If it hasn't, the only cure is to disconnect the damper filament

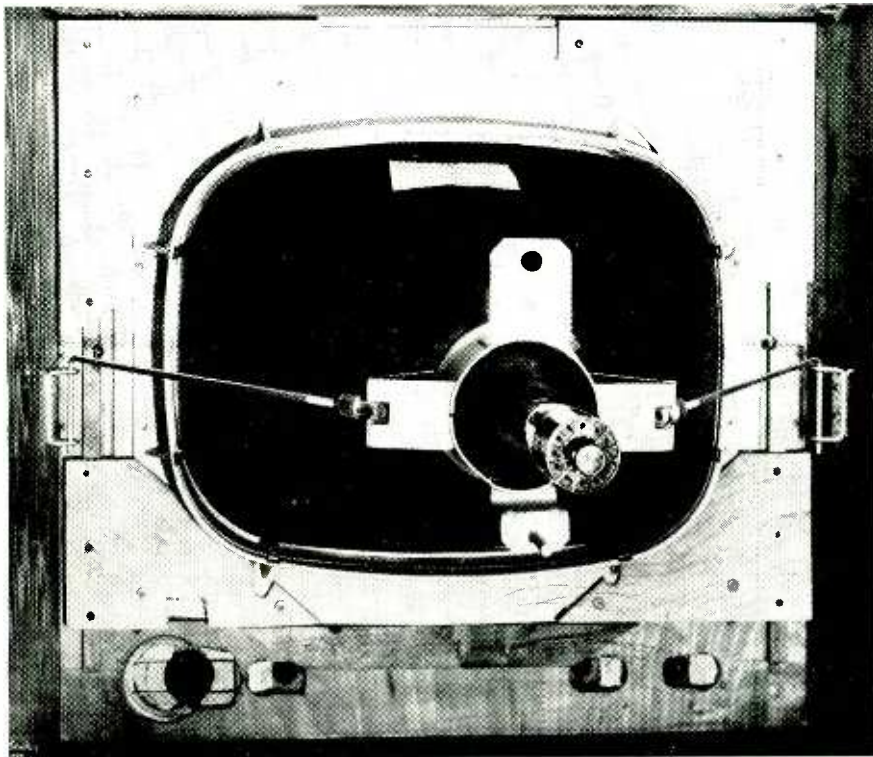

Fig. 6—New tube in 8T244 cabinet. Mask and bracket are for RCA 17-inch receiver.

decade is handy. This careful peaking adjustment can make a big improvement. It is particularly valuable when converting to 20-inch or larger rectangular tubes where maximum sweep and high voltage are important.

One last word about foldover. Added capacitance increases retrace time and foldover troubles. By the same token, adding *shunt inductance* will tend to *reduce* retrace time and foldover troubles since the reduction in total inductance *increases* the natural resonant frequency of the system. Suppose a converted set has no width control but has excessive width and foldover. Adding an inductive width control will pull down the width and reduce foldover. The trick is to have extra width to

design value for the 231T1 appeared to be about 12 to 15 ma. The original circuit of the 8T244 receiver drew just about this amount from the old flyback transformer so no circuit modification was needed. In some conversions it may be necessary to add a bleeder between B plus and the boosted B plus (as shown in Fig. 4) to increase the drain on the boosted supply and thus provide proper linearity. The peaking adjustment (and the drive setting) have an effect on linearity too, but their effect is generally confined to the left half of the picture.

Picture blooming

Another frequent trouble in conversion work is blooming. The picture en-

from the receiver supply and install a separate damper-tube filament transformer. Be sure the new transformer has at least 5-kv (peak) insulation between the primary and secondary. If the old damper tube is a 5V4-G it can be replaced with a 6W4-GT and a 6.3-volt filament transformer installed (Stancor P-6134 or Merit P-3074).

The second point is whether or not to use a limiting resistor in series with the high-voltage rectifier filament. If the conversion is to a 53-degree tube (12 to 16-inch) the resistor isn't usually necessary. With a 17-inch tube it's a debatable point. We didn't use one. If you want to insure longer h.v.-rectifier life, use a 2- to 3-ohm resistor. Always use this resistor for larger tubes, where maximum high voltage and width are needed.

The last point is the series-isolating high-voltage resistor described in last month's article—usually a 500,000-ohm to 1 megohm unit. This resistor is especially important when glass picture tubes with external conductive coatings are used. It prevents the picture-tube capacitance from shunting the deflection secondary of the flyback transformer. Use of this resistor is recommended in all conversions.

Other changes in 8T244

When the horizontal-circuit changes were completed, the boosted B plus voltage had increased. Therefore the original circuit connections to pin 10 (the screen grid) of the picture tube had to be modified to keep the screen-grid voltage below 410, the maximum allowable for a 17TP4. Fig. 1 of last month's installment shows the voltage divider arrangement for reducing this voltage.

It consists of a 750,000-ohm and a 1.5-megohm resistor from the junction of R156 and C146B to ground.

Pin 6 of the picture tube (the focusing electrode) was connected to B plus 215 volts. A refinement would be to connect a 5,000-ohm potentiometer from plus 215 volts to chassis with the slider going to pin 6 of the picture tube for adjustable focus.

Vertical-circuit changes

After the changes described above the set was tested with the new tube. Minor horizontal troubles were easily cleaned up by following the procedures already suggested. But vertical size and linearity were not acceptable. First, the 6K6-GT vertical output amplifier was replaced with a 6V6-GT. Height improved but vertical linearity was still poor. It was best at the minimum-resistance setting of the linearity control, so we shorted out R161, the 2,700-ohm resistor in series with the control. See Fig. 5. Now the control could be adjusted to a point giving good linearity.

(Another solution could have been used for inadequate height: The plate-decoupling resistor R165 for the vertical output tube could have been disconnected from plus 215 volts and connected to the boosted B plus voltage. In this case, C148C would have had to be replaced with a 600-volt unit. It is *not* a good idea to raise the vertical amplifier plate voltage by *decreasing* the value of the plate decoupling resistor. Undesirable coupling between the vertical and horizontal sweep circuits sometimes occurs when this resistor is reduced in size.)

The last change was to replace C146B, the 10- μ f filter capacitor between the height-control (R155) slider and minus 120 volts, with a 600-volt, 10- μ f capacitor because of the higher voltage from the boosted B plus source.

The method of mounting the new tube in the old cabinet is shown in Fig. 6. The mask and bracket used are standard replacement parts for a 17-inch RCA receiver.

The 17TP4 requires a small external centering magnet. This magnet is placed as close to the back of the yoke as possible.

Converting the RCA 730TV1

An example of another 17-inch conversion is shown in Fig. 7. This shows the circuit changes made in the vertical and horizontal sweep systems of an RCA 730TV1—a particularly difficult set to convert. Circuitwise it is very similar to the Tele-Tone TV209, TV210, and TV249 receivers.

The 231T1 transformer and the 211D2 deflection yoke were used in this conversion too. However, the circuit revisions in the vertical output stage were more extensive, since the original output tube was one section of a 6SN7-GT. This was replaced with a 6BL7-GT, and B plus for the output section was taken from the boosted B plus supply, directly from the cathode of the damper tube rather than from terminal 1 on the flyback transformer. This connection gave the best horizontal linearity.

The vertical output transformer had to be replaced with an autotransformer having an 18-to-1 ratio because of the higher source impedance resulting from the use of boost voltage. Whether or not the vertical output transformer must be replaced in any given conversion depends on the impedance of the vertical windings in the new yoke. (In vertical windings the resistance is the most important factor. Inductance is relatively unimportant because of the low frequency (60 cycles). If the resistance is markedly different from the old yoke windings, you may have to replace the output transformer to get a better match.

Check List on conversion problems

Factors affecting high voltage (assuming all tubes are perfect):

1. High-voltage rectifier filament voltage.
2. Drive voltage (peak-to-peak amplitude).
3. Peaking-circuit adjustment.
4. Receiver B supply voltage.
5. Boosted B supply current drain.
6. Length of lead to plate cap of high-voltage rectifier.
7. High-voltage capacitor leakage.
8. Shunt capacitance across deflection secondary winding.
9. Condition of linearity-control bypass capacitors.
10. Horizontal-amplifier screen power input.

Factors affecting width:

1. Series capacitor blocking d.c. from horizontal yoke windings. (Small values give greatest width.)
2. Drive voltage (peak-to-peak amplitude).
3. Peaking-circuit adjustment.
4. Added capacitance across deflection-secondary taps. (Also affects retrace.)
5. Receiver B supply voltage.
6. Boost voltage.
7. Horizontal-amplifier and damper-tube condition.
8. Value of width control (if used).
9. Condition of linearity-control bypass capacitors. (Leaky capacitors affect

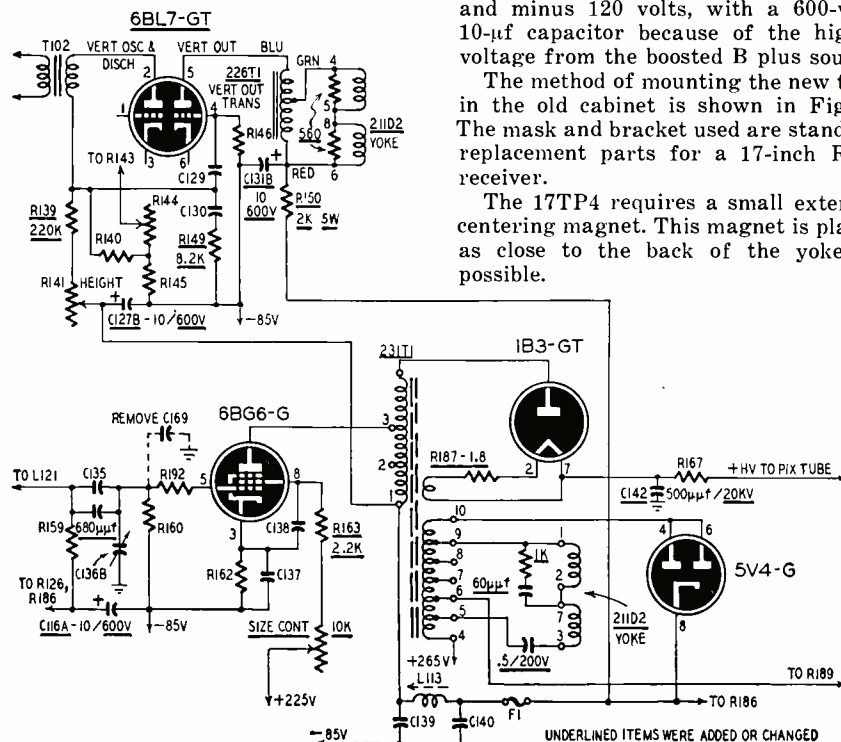

Fig. 7—Diagram shows modifications in the deflection circuits of RCA 730TV1.

TV DX IN SEPTEMBER

left side of picture; open capacitors affect right side.)

Factors affecting linearity:

1. Boost-supply current drain (12 to 15 ma in addition to horizontal-amplifier plate current with 231T1 flyback transformer).
2. Inductance of linearity coil and ratio of linearity bypass capacitors.
3. Drive waveform.

Factors affecting brightness:

1. Ion-trap magnet adjustment.
2. Picture-tube screen-grid voltage (300 volts minimum for 17-inch tube).
3. Condition of picture tube. (Gassy tube draws too much current and reduces high voltage.)
4. Magnetic-focus tubes: Alignment of yoke and focus coil (or magnet) on neck. In case of shadow trouble wedge the yoke in correct position with paper shims before installing focusing device. (Use low-voltage electrostatic-focus tubes wherever possible.)

Factors affecting h.v. regulation:

1. High-voltage rectifier condition and filament voltage.
2. Value of high-voltage isolating resistor.
3. Match between yoke and deflection secondary.
4. Value of charging resistor in voltage-doubler circuits.

Factors affecting horizontal retrace time:

1. Capacitance (stray or inserted) across flyback secondary increases retrace time, emphasizes left-hand foldover. Inductive shunt-type width control reduces secondary inductance, reduces retrace time and left-hand foldover.
2. Length and dress of high-voltage rectifier plate-cap lead. (Keep short and dressed away from other components and chassis to reduce capacitance to ground.)
3. Yoke connected to wrong deflection-secondary taps.
4. Phasing of feedback circuits inductively or capacitively coupled to flyback secondary.
5. Omitting high-voltage isolating resistor or using one whose resistance is too low. (Shunts picture-tube capacitance across entire secondary system.)

—end—

HAM-BAND INTERFERENCE

Interference from amateur transmitters in the new 21-21.45-mc band should not affect older TV receivers with sound i.f.'s 21.7 mc or higher. These include Andrea, Belmont, Cascade, Crosley, Du Mont, Firestone, Hallicrafters, Philco, Sheraton, Sightmaster, Stromberg-Carlson, and Transvision. (See RADIO-ELECTRONICS for January, 1952.) Newer receivers with 44-mc i.f.'s might pick up second harmonics of the new band, but in these cases the fault would lie with the amateur, who is required by law to eliminate harmonics of the transmitter frequency.

The early fall is one of the low periods of the year for sporadic-E skip, the phenomenon that most of us think of as synonymous with dx, so the viewer who is looking for signals from more than a few hundred miles away will almost certainly be doomed to disappointment during September. There may be a few scattered dx openings, but they will be short, and signal levels and geographical extent will not compare with the summer sessions.

This is a fine time of year for tropospheric bending, however, and the observer who has a sensitive receiver and a good antenna system will find it well worth while to watch both low and high channels carefully. The early morning hours will show the strongest signals ordinarily, and the many stations now transmitting as early as 7 am make it possible for the early riser to make interesting observations. Cool nights following fair, warm, days, a weather pattern common over the northern half of the country in September, will also provide higher-than-average signal levels in the evening hours.

Reception of signals from 1,200 miles or more away, such as was possible frequently during the early summer, is a thrilling experience to say the least, but it is not necessarily proof of superior receiver or antenna performance. The reflection characteristics of the E region of the ionosphere are such that low-channel dx signals may be extremely strong, occasionally blocking out or

seriously interfering with local stations. Obviously, it doesn't take a hot receiver or a high-gain antenna system to pull in this kind of dx, interesting though such reception may be.

Tropospheric bending associated with weather effects, on the other hand, seldom brings in really strong signals from distant points. Rather, it serves to increase the strength of fringe-area reception, and occasionally brings in signals that are not receivable at all under ordinary conditions. There is little or no skip effect, the signal being receivable over the entire path from the transmitter to perhaps several hundred miles out. Because signals of this kind are seldom extremely strong, good reception of them is almost wholly a function of the efficiency of the receiver and its antenna system.

The higher the frequency the greater is the effect of the fall inversions in increasing the signal strength, a fact not readily apparent to most viewers because of the relatively poor performance of most receivers on the high channels. A really large array (the amount of energy an antenna will intercept is determined by its frontal area, more than by the number of elements) and a low-noise preamplifier designed for good high-band performance may bring in signals on channels 7 through 13 that most viewers never see. The next two months are the best time of the year to try for this sort of thing.

—end—

AIRTIGHT DOME SEALS FLYBACK UNIT

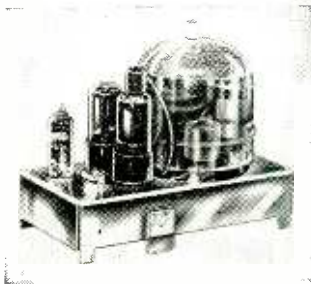
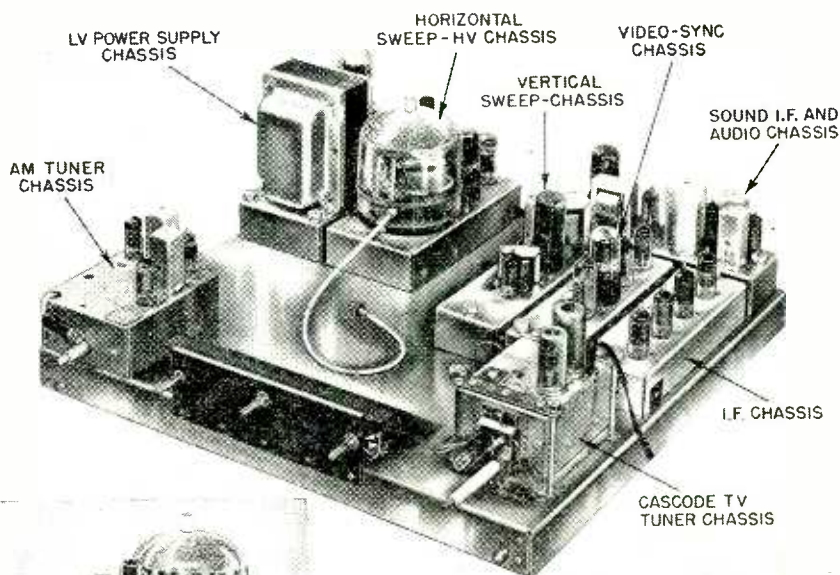

Plug-in TV chassis has new hermetically-sealed h.v. unit. The Setchell-Carlson Unit-ized Chassis 152, in addition to individually removable subsections, now features a dust- and humidity-proof housing for the flyback, h.v., and deflection components. The upper portion of the plastic enclosure is filled with moisture-absorbing silica gel. The dome can be removed for servicing and resealed for full protection.

RETRACE BLANKING IN TV RECEIVERS

By GAIL W. WOODWARD*

D. C. RESTORATION in television circuits has always been a problem. This is emphasized by the large number of lengthy attempts to merely explain the concept. True d.c. restoration is very difficult in view of the poorly-maintained standards for sync-to-video amplitude. In fact, some stations do not even maintain constant sync amplitude. Since most d.c.-restoration circuits use the sync peaks as a reference level, the observed black reference level will vary from station to station.

This problem has been attacked from several directions. One solution is the line-to-line clamping circuit described in the March, 1952, issue of *Electronics*, which solves the problem in a somewhat costly manner. Another approach was found in the complete removal of d.c. intelligence from the picture. Strangely enough, this method worked—it was found that a picture does not need d.c. restoration for customer approval. The eye registers *gradations of brightness* without too much regard for overall intensity. After this factor was discovered, many manufacturers merely removed the d.c. restorer circuit from the receiver. However, some set owners noticed that horizontal lines sometimes appeared in the darker scenes. The disturbing effect of these "white lines" was the only objection to the loss of d.c. picture intelligence. The remaining problem was to eliminate these objectionable lines.

Vertical-retrace blanking

The vertical return trace can be blanked in several ways. The first consideration is the method of feeding video to the picture tube. Some circuits feed video—with positive-going sync pulses—to the picture-tube cathode; other circuits feed video—with negative-going sync pulses—to the picture-tube grid. The latter is more common. If the tube is grid fed, the return trace can most easily be blanked by feeding a positive-going pulse to the cathode. The positive pulse should have a duration equal to the vertical-retrace period, and an amplitude of 50 to 100 volts.

Fig. 1 shows a practical form of cathode-fed blanking. Blanking voltage is derived from the plate of the vertical-output tube through a simple network (shown connected by broken lines). The R-C product (time-constant) of the blanking circuit is made very close to 850 microseconds—short compared to the vertical-sweep period (1/60 second, or 16.666 microseconds), and fairly long compared to the vertical-

retrace period (200 to 400 microseconds in most cases). The exact time-constant will depend on the characteristics of the receiver. This figure of 850 microseconds has been found applicable to a great many sets, but will not work equally well in all cases.

The vertical-output waveform (E_p) is shown at the plate of the vertical amplifier. The sweep period is shown as a negative-going sawtooth, while the retrace occurs during the positive-going pulse. The blanking circuit differentiates the vertical-output wave. The resultant waveform appears as a positive pulse at the picture-tube cathode and cuts off the beam current during the retrace period. Since the plate waveform is of very high amplitude (up to 1,500 volts peak-to-peak in some cases), a voltage-divider is used to give about an 80-volt peak-to-peak blanking pulse. In receivers where the vertical output is more or less than 1,500 volts, the value of the 15,000-ohm resistor can be changed accordingly. For example, if the vertical output is 750 volts peak-to-peak, the 15,000-ohm resistor should be changed to about 30,000 ohms. This adjustment can be made without altering the blanking-circuit time-constant value materially.

Where this circuit is being installed in an unfamiliar receiver for the first time use a 50,000-ohm potentiometer in place of the 15,000-ohm resistor, and a 500,000-ohm potentiometer in place of the 270,000-ohm resistor. Start with the 50,000-ohm potentiometer at about one-fourth maximum resistance, and adjust the 500,000-ohm potentiometer for the correct waveform. Then adjust the 50,000-ohm potentiometer for the desired pulse amplitude. Measure the two potentiometers and substitute fixed resistors of equivalent values.

Parts placement is somewhat critical, but if the 270,000-ohm resistor is attached directly to the plate terminal of the vertical-output tube socket with as short a lead as possible, very little difficulty will be experienced. If a long plate-circuit lead is used there may be undesirable radiation.

Fig. 2 shows the effects of incorrect time-constant in the blanking circuit. Fig. 2-a indicates excessive differentiation produced by too-short a time constant. This can be corrected by shunting additional capacitance across the .003- μ f capacitor. Fig. 2-b shows the effect of too-long a time constant, which can be corrected by shunting the 270,000-ohm resistor to a lower value. The first waveform will cause a bright bar across the top of the picture; the second will

create a dark bar by blanking out the upper portion of the picture.

If the video signal is applied to the cathode, it is advisable to use grid blanking as shown in Fig. 3. Grid blanking requires the application of a negative pulse to the picture-tube grid during retrace. Since the vertical-output transformer (in most receivers) inverts the waveform, the differentiated pulse from the secondary will be negative. The waveforms for Fig. 3 are similar to those in Fig. 1, except for polarity and amplitude. The time constant is not changed but the voltage-division ratio is different. The division ratio for Fig. 3 is $2\frac{1}{2}$ to 1 as compared to a ratio of 19 to 1 for Fig. 1. The method of exact adjustment is the same.

(If the transformer does not invert the waveform that appears at the plate side, reverse one pair of transformer leads (either primary or secondary) and reverse the vertical deflection-coil leads.)

In some cases it may be desirable to connect a .001- μ f capacitor across the 15,000-ohm resistor, as shown in Fig. 3. This capacitor will bypass any horizontal-sweep signal that may be picked up by electrostatic cross-talk between the horizontal and vertical coils in the deflection yoke.

Some receivers use an autotransformer, which does not invert the plate waveform, in the vertical-output circuit. It is not advisable to change the circuit since the desired effect can be obtained with the arrangement shown in Fig. 4. In this case, the grid waveform is used as a signal source for the differentiator circuit. It is important not to load the high-impedance grid circuit; loading is prevented by using a high value of resistance and a small capacitor. The waveforms are similar to those of Fig. 3, and the time-constant can be adjusted in the same way.

The circuit of Fig. 5-a has the advantage of working equally well with either cathode video injection or grid video injection. In this circuit, a single triode (shaper tube) is required to provide a controlled waveform. One section of a 6SN7-GT (or equivalent) is most often used. The blanking voltage, in the form of a negative-going pulse, is applied to the first anode (grid No. 2) of the picture tube.

Fig. 5-b shows the waveforms at the grid and plate of V1. The large signal input develops a corresponding value of negative bias by grid rectification; the tube conducts only during the most positive portion of the input wave. When the input voltage drops below

* Philco Corporation, Philadelphia, Pa.

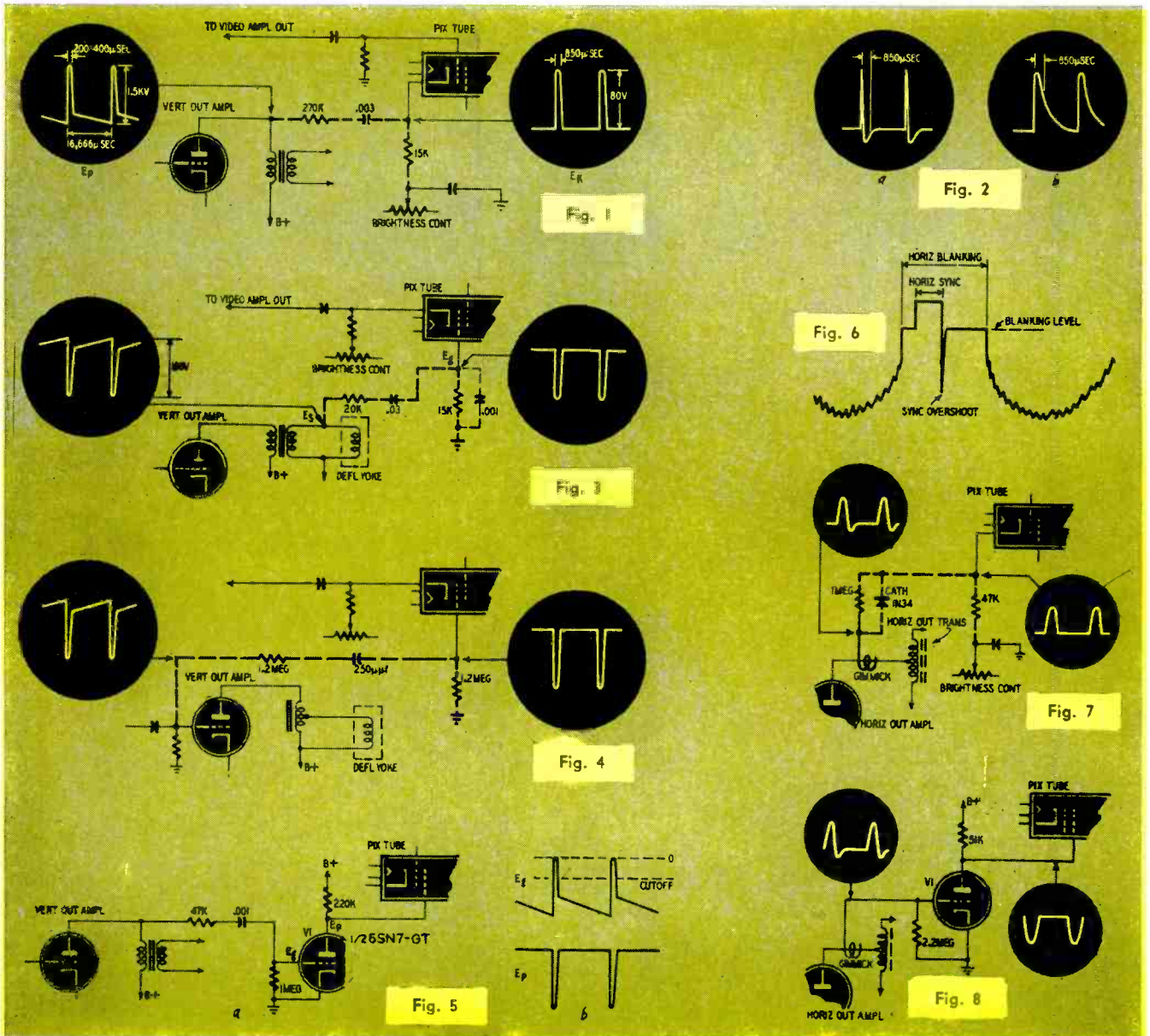

the cutoff point of the tube, the plate remains at B plus potential. The short conduction pulse during the retrace period drops the plate voltage to a very low value, removing the first-anode potential from the C-R tube.

Horizontal-retrace blanking

Adding horizontal-retrace blanking can cure a common trouble known as sync overshoot which originates in the transmitter. The sync pulse is followed by a narrow reverse spike extending down into the white region. See Fig. 6. It shows up in the receiver as a vertical white bar which can be shifted with the hold control, but cannot be eliminated. The spike occurs during the horizontal retrace interval. This accounts for the width of the vertical white bar—retrace in the TV set is at such high velocity that the spike is spread out.

One method of eliminating the effect of sync overshoot is to reduce the receiver bandwidth to a point where response to the overshoot frequency is eliminated. This works, but reduces picture quality considerably. The best ap-

proach found so far is a horizontal-retrace blanking circuit. The object is to drive the C-R tube so far beyond cutoff that the white-level spike will still not be sufficient to cause conduction.

Fig. 7 shows a successful method for horizontal-retrace blanking. The parts connected by dashed lines are added components. A gimmick is used to couple a small portion of the signal at the plate of the horizontal output tube to the picture-tube cathode; the positive flyback pulse drives it well into the cutoff region. The crystal diode and resistor act as a limiter to prevent the negative overshoot which usually follows the horizontal-retrace pulse from appearing on the screen. (If the horizontal output waveform has no overshoot, the crystal can be eliminated.) The waveform at the cathode is a positive pulse during retrace, and a flat portion during the normal trace period.

If this circuit is overcoupled, it is very easy to burn out the 1N34. A 1N39 or 1N55 will be helpful, but more expensive. Burnout can be avoided if

the gimmick is wound while the circuit is in operation and a calibrated oscilloscope used to monitor the pulse amplitude at the cathode of the picture tube. Slowly increase the gimmick capacitance until a cathode pulse of about 50 volts is obtained.

If cathode blanking of the horizontal retrace is undesirable, the coupled pulse can be applied to an inverting amplifier and then fed to the grid. It would also be possible to apply the pulse to an amplifier which has its output connected to the first anode, as shown in Fig. 8. In this case the gimmick coupling should be adjusted until the negative-input swing is below the cutoff point of V1. Final adjustments should be made to give the desired blanking waveform.

Retrace blanking is a very definite necessity in modern TV receivers, and is included—to some degree—in most sets now being produced. Vertical retrace blanking has become almost a standard circuit, but unfortunately horizontal retrace blanking is not widely used.

—end—

TV SERVICE CLINIC

Conducted By
MATT MANDL*

WE receive numerous queries regarding fringe-area reception. Often the question of using the Yagi antenna arises. For this reason we will discuss some of the factors involving Yagis. For those who want to construct their own or who want to shop for a particular type, diameter relationships for obtaining the necessary 300-ohm impedance are given.

The Yagi antenna has considerably more gain than the ordinary television types. A four-element Yagi (Fig. 1) has a theoretical gain of over 9 decibels compared with an ordinary dipole. When a reflector and several directors are added to *any* antenna, its impedance drops appreciably. Thus, if a folded dipole were used for the Yagi, its impedance would drop to 30 ohms and create a severe mismatch with 300-ohm line.

Most manufacturers modify the folded dipole in order to regain the higher impedance. One method is to use different diameters for the fed element and the unbroken element (Fig. 2). The impedance depends on the ratio of spacing to element diameter; examples of the calculated dimensions for 300 ohms are given below:

Unbroken Element Diameter	Fed Element Diameter	Spacing (Center to Center)
3/4"	3/8"	1.6"
1"	3/8"	2"

These dimensions apply only to the four-element Yagi shown in Fig. 1. If additional directors are added, the impedance will again drop below 300 ohms.

For maximum gain, the spacing between directors should be 1/10 wavelength and the reflector should be spaced from the antenna by 0.15 wavelength. More than one reflector adds little to gain.

It must be remembered that the Yagi has one serious disadvantage. This is the narrow band over which it will work. Usually the Yagi is suitable only for the station to which it is cut. It will not bring in adjacent channels well unless they are much stronger than the

station for which the Yagi was designed. Special types, like the twin-driven Yagi, are suitable for two channels but are still not broad-band antennas like the standard biconical types. If additional fringe-area stations are to be received, several Yagis will have to be erected, preferably with separate lead-ins. These can be switched into the receiver as required.

Stacking helps if *each antenna is cut for the same channel*. Half-wavelength spacing is best because it maintains the desired forward lobe and increases gain by an additional 4 db. The stacked array is fed at the center of the connecting bars as detailed in the Television Service Clinic in the June, 1952, issue.

Antenna dimensions

I am stacking Yagi antennas for channel 5 and would like to know if 72.8 inches is the correct measurement for one-half wavelength. Please advise me just how one arrives at the proper wavelength measurement in inches. C. S. W., Pocahontas, Va.

The dimension of 72.8 inches is the proper measurement for channel 5 connecting bars for Yagi stacking. This is a "free-space" measurement and does not apply to transmission lines with insulating material.

For one-half wavelength in feet, the following formula applies:

$$492$$

freq. (in megacycles)

Because of "end effect" antennas are cut 5% shorter than the length given by the formula. Reflectors are usually 5% longer than antennas, while directors are 4% shorter.

Regulating a.g.c.

I would like to know if it is possible to put a switch in the a.g.c. circuit of an Air King 700 receiver so that I can switch out the a.g.c. when the signal is weak. I live a hundred miles from channel 4. Is there any change that I could make in the circuit of the receiver to increase the gain? L. W., Ravenwood, Mo.

Instead of a switch we recommend that you replace the 4,700-ohm fixed resistor with a 5,000-ohm potentiometer. This will give you control over a.g.c. to



prevent overload on extra-strong signals. Fig. 3 shows this control.

We do not recommend any other circuit changes in this receiver. You could improve reception by increasing antenna height and using open-wire or slotted transmission line. Some hints on fringe-area reception were given in the Television Service Clinic in the February, 1952, issue.

Line interference

A Zenith receiver is picking up power-line noise, making the picture jitter sideways. This is more pronounced on a weak signal. What type of filtering can be used to correct this condition? The receiver is located near a high-tension wire system across the road. It does not interfere all the time, but only on occasion and particularly for a weak signal. What type of line filter or other corrective measure can I employ? D. S. Madison, Maine.

Arcing or corona on the high-tension line could cause the severe interference you mention. If such is the case the power company should be notified so that they can take corrective measures.

Try a 0.1- μ f, 600-volt paper capacitor across the a.c. power line feeding the receiver. You could also use a Drake, JFD, or Tele-matic ignition filter at the antenna terminals of the receiver. See your local television parts jobber for the various antenna filter units available. Sprague Products Co. also makes a special line filter (0.1- μ f, 250-volt a.c. rating), which could be used instead of the 0.1 μ f mentioned above.

Improving signal pickup also will help. This means having a good antenna system, as well as a properly-aligned receiver with good parts and tubes.

Jitter and poor focus

In an Admiral model 26R36, chassis 24F1 receiver there is a pronounced vertical flicker. Focus is also poor and cannot be corrected by the focus control. When this receiver is shut off, there is an afterglow, and I was wondering whether this will eventually cause an ion burn? W. O., Chicago, Ill.

The vertical flicker would most likely be caused by a defect in the vertical sweep section of the receiver. Check the

* Author: Mandl's Television Servicing

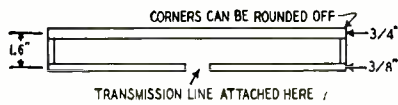

Fig. 1 (opposite page)—Basic four-element Yagi antenna discussed in the text.

Fig. 2 (above)—Special driven element raises Yagi impedance to 300-ohm value.

6SN7-GT vertical oscillator as well as the 6S4 output amplifier. If the tubes are ok, check all resistors and capacitors in the R-C network feeding the oscillator, as well as all parts in the oscillator-amplifier circuits. If only the top of the picture jitters (for about 2 inches) dress the white lead from the horizontal hold control away from the vertical output transformer. Also check C417 (the 20- μ f electrolytic capacitor in the vertical output circuit) for leakage.

Lack of focus in run 3 of chassis 24F1 is often caused by variations in characteristics of short-neck picture tubes. A 2-watt resistor (R328) was added in later production models as shown in Fig. 4 to improve focus. As the current from the focus coil also goes to the audio amplifier, a defective 6V6-GT audio-output tube sometimes causes this trouble.

The afterglow which you notice is not harmful provided the iron trap is adjusted properly. The afterglow is caused by the charge remaining on the high-voltage capacitors maintaining the electron stream while the cathode cools. This is no more harmful than any bright televised area during normal reception.

Lack of contrast

In an RCA 8T-241 receiver the contrast control must be turned fully clockwise before a fair picture is procured. When I turn up the brightness, retrace lines are visible. Brightness seems adequate but contrast does not. N. R., Brooklyn, N. Y.

The fact that you have to turn the contrast up fully to get a fair picture indicates lack of video signal strength at the grid of the picture tube. This could be caused by the following trouble (or troubles):

- Defective part or tube in tuner
- Defective part or tube in a.g.c. circuit
- Defective part or tube in video i.f. stages
- Defective part or tube in detector and video amplifier
- Improperly tracked tuner
- Misaligned i.f. stages
- Defective antenna system
- Defective contrast control
- Defective picture tube

Test all tubes from tuner to video amplifier feeding the picture tube. If these check all right, your only recourse is to check all the conditions listed above.

Fringe-area problems

I live in an ultra-fringe area 100 miles from Birmingham, 120 miles from Memphis, and 145 air miles from

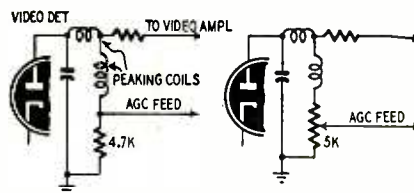

Fig. 2—The original circuit is on the left. Modified circuit is on the right.

Nashville. Using an RCA 6T74 receiver with a booster, antenna rotator, and 5-element Yagi cut for channel 4, I get inconsistent reception. Sometimes all three stations come in perfect and at other times I get no signal at all.

All stations which I receive are on channel 4. The only station in my area which I do not receive is WAFM-TV in Birmingham, channel 13. I have tried a 5-element Yagi cut to channel 13, but even with a booster I have never received any reception in the two years I have had my receiver. The antenna is located on a 60-foot tower and our geographical location is high. Will you please tell me if there is anything I can do to receive channel 13 and improve channel 4 reception. R. R., Red Bay, Alabama.

Using a booster, a rotator, and a 5-element Yagi should give you more consistent reception than you are getting from channel 4, though the distances involved contribute pronounced effects from atmospheric conditions. Try an open-wire or slotted transmission line if you do not have one already. These have much lower losses than the solid-insulation types. You could also modify the receiver as detailed in the Television Service Clinic in the February, 1952, issue of RADIO-ELECTRONICS.

You should be able to get channel 13, as this station is nearer than the other two. Losses are greater for the higher frequencies, and extra precautions must be taken to minimize standing waves and attenuation. Use low-loss insulators and space the transmission line at least 6 inches away from the antenna mast and other metal objects. Wrap a 4 x 8-inch piece of tinfoil around the transmission line near the receiver antenna terminals. Slide this section up and down the line to tune for maximum pickup on channel 13. Also check the oscillator tracking in the receiver for this channel, as this may be the primary trouble.

Rectifier replacement

In a Westinghouse model H-619T12 receiver, two 6W4 low-voltage rectifiers are used. One of these rectifiers burns out repeatedly. I replaced both and the receiver worked fine for two months and then again the same one burned out. I replaced the tube and it lasted only a week. Upon checking the circuit with new tubes the receiver functions normally. All voltages and resistances are as indicated in the manufacturer's schematic. E. K., Buffalo, N. Y.

The two 6W4's in the low-voltage system function as a combined full-wave rectifier with equal distribution of the load. One tube shouldn't go bad re-

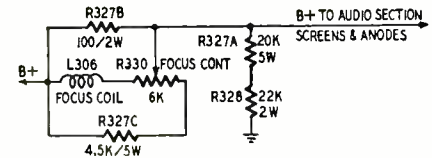

Fig. 4—The addition of R328 improves focus in Admiral 24F1 television sets.

peatedly unless by coincidence the replacements were inferior. A defective socket could cause this condition. Corroded terminals or poor contacts might reduce the filament potential. Check the 6W4 socket connections.

The fact that only one tube is short-lived might also indicate that some intermittent overload occurs during operation. Check the filter capacitors to make sure their leakage hasn't increased, and check tubes and capacitors throughout the receiver. It would also be well to fuse the power supply to protect the rectifiers during momentary overload.

Repeated field-coil burnout

In a Motorola 17T1 receiver, the field coil of the speaker has burned out several times during the past year. What could be the reason for this? E. M., Gunter, Texas.

In this receiver it was found that some early-model transformers gave a B plus voltage 10 volts too high. For protection, a 150-ohm 15-watt resistor was inserted in the speaker field line (R104 in the new schematics). Check to see if this is in your receiver; if not, adding it may prevent speaker-field burnout.

Excessive buzz in Crosley

In a Crosley model 11-445M receiver, there is hum on all channels. Adjustment of the fine tuning lowers the hum, particularly if the fine tuning is turned away from the point of maximum reception. All tubes seem to check all right. What could cause this trouble? G. C., Long Island, N. Y.

This is an intercarrier-type receiver and the noise might be intercarrier buzz as well as power-supply hum.

Intercarrier buzz may be caused by incorrect alignment of the video i.f. stages. If the sound i.f. is not at the correct level on the response curve, severe intercarrier buzz will result. The settings of the fine tuning and contrast controls will change the degree of hum.

In some models electrolytic capacitor C120 did not have a good ground connection and this caused the hum and buzz symptoms. A wire should be soldered from the chassis to one of the grounding lugs on the capacitor if this has not been done at the factory. Also try adjusting the ratio-detector-transformer secondary by turning the screw slightly to left and then to right to find the setting which gives minimum hum. Make sure the back of the contrast control is shielded and that audio-coupling capacitors are dressed away from hum fields.

—end—

TRANSMISSION LINE TUNER

By ED NOLL and MATT MANDL



Fig. 1—Line tuner control circuit.

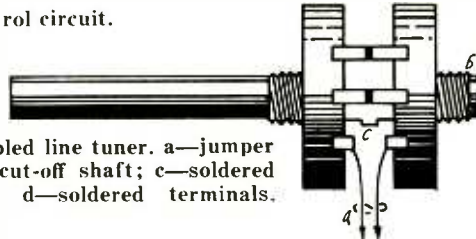
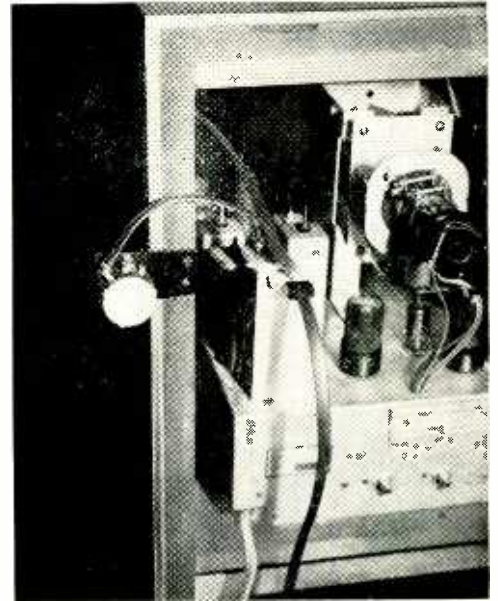
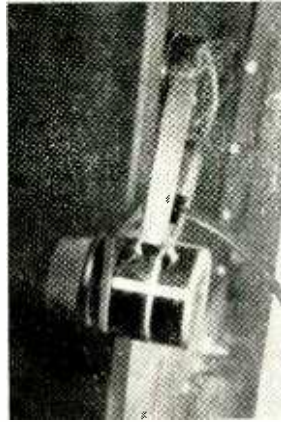

Fig. 2—Assembled line tuner. a—jumper to TV set; b—cut-off shaft; c—soldered switch levers; d—soldered terminals.



Above—left—Coupled units form TV line tuner. Above—Installation provides easy access to tuner from front of TV set.

TRANSMISSION line tuning is especially important—if ghosts are to be minimized and signal-to-noise ratio improved. Ever since our series of articles* on antennas and transmission lines, we have received numerous requests for information on practical methods of tuning the line.

Wrapping a 4-inch length of tin foil around the line and sliding it along the lead-in for best results has long been a favorite trick of TV technicians for improving television picture quality on the upper channels. Ribbon transmission lines can be improved by attaching matching stubs of proper length to the receiver antenna posts. But, while they appreciate the improved results, customers object to the awkward process of reaching behind the receiver to adjust the tin foil or connect stubs.

One simple but effective way of matching or tuning the lead-in is to use a dual potentiometer hooked up so that it acts as a variable section of a transmission line. Such a device is shown in the photographs and consists of a dual 6-ohm-per-section wire-wound potentiometer. The actual resistance value is not critical and may run up to 50 or 75 ohms, but each section must have the same resistance.

Two end terminals and the center

terminals of the dual potentiometers are gang-soldered. The other two terminals are connected in parallel with the transmission line at the television receiver antenna posts. The connection from the dual control to the receiver should be made with a short length of ribbon line. Fig. 1 illustrates the actual circuit of the dual potentiometer.

The unit is mounted on a small piece of bakelite, wood, or hard rubber and fastened to the rear of the receiver with the shaft projecting along the side for convenience in adjusting. A small knob is placed on the end of the shaft.

With a station tuned in, the knob is turned until the best picture quality is obtained. In modern receivers having a.g.c. there will not be any appreciable change in contrast, except for very weak stations; however, over-all improvement in picture quality and a decided reduction in snow is usually noted.

Two separate wire-wound potentiometers can be used if it is difficult to obtain the low-resistance dual wire-wound potentiometer. These units must have a trip lever for an a.c. snap-on switch on the shaft. Fig. 2 illustrates the method of combining the two potentiometers in making the dual control. The shaft of one of the potentiometers is cut off almost flush with the threaded mounting sleeve. Use a file to re-

move any rough edges on the cut shaft.

Align the trip levers and solder them together. Next solder the outside and center terminals together, leaving the opposing pair of outside terminals open for connection to the receiver. A short section of ribbon line is soldered to these end terminals.

The two potentiometers should be very close together so that the unit may function as a tunable stub. The resistance wire forms the series inductance and the proximity of the two elements creates the necessary capacitance.

A few years ago several manufacturers marketed small transmission-line tuners for TV sets. Set owners and technicians did not realize their advantages, and the devices were withdrawn from the market. The Standard Transformer Corporation had a device called "Telematch," and the Snyder Manufacturing Co. produced a unit similar to the one described. Some purchasers were enthusiastic about the results and are still using them on their receivers. Similar improvements can be achieved by constructing the dual-control affair discussed in this article, unless, by remote coincidence, you have the perfect transmission line, and have it exactly matched to both the antenna and the receiver input impedance!

—end—

*RADIO-ELECTRONICS, Jan.-June, 1949.

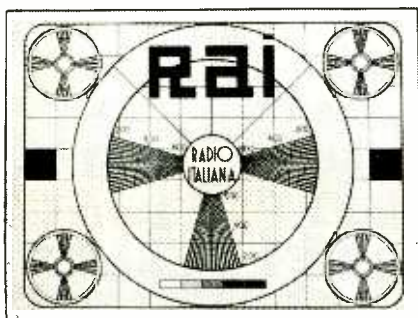

600-line pattern sent by Italian stations.

TELEVISION IN ITALY

TV in Italy has made rapid technical strides despite shortages of test equipment and receivers. The Italian Radio (RAI) has been training technicians and cameramen for the past two years in an experimental station in Turin. Now Milan is on the air with a 5-kw General Electric transmitter and 6-bay "superturnstile" antenna giving 35 kw effective radiated power. Video is

175.25 mc, sound 180.75. Turin and Milan are connected by a radio link until a coaxial line is completed.

Italian stations transmit the new European standard 625-line picture, with a video bandwidth of 5 mc.

The Italian government plans TV coverage for 13,000,000 people in the northern part of the country by 1953.

—end—

Get peak performance from small sets by using the

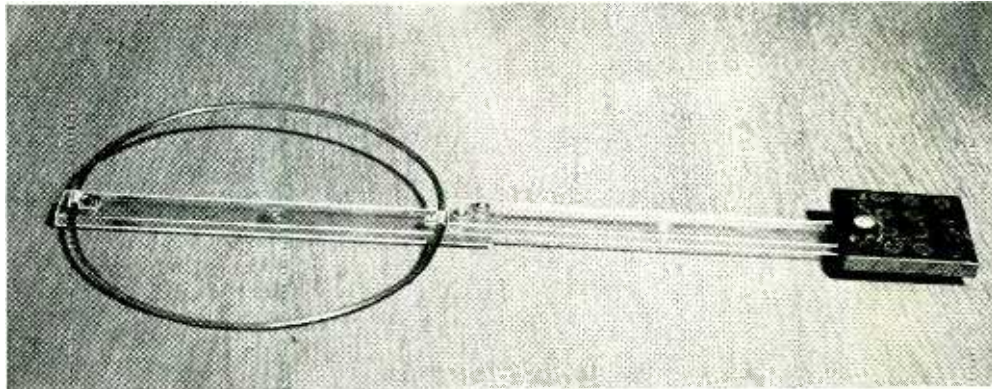

TUNING WAND as a SERVICE TOOL

By GERALD J. MACHEAK

MOST small a.c.-d.c. sets have inadequate gain at the low-frequency end of the dial due to imperfect tracking between r.f. and oscillator sections. Manufacturers usually peak the oscillator at 1600 to 1700 kc, then adjust the r.f. trimmer for maximum output at 1400 kc, and let the low end take care of itself.

Practically all modern tuning capacitors have split end plates for adjusting the oscillator-r.f. tracking at several points on the dial. With the aid of the simple service tools described here, any set with split-plate tuning and a built-in loop antenna can be aligned for almost perfect tracking, with improved sensitivity and selectivity, especially at the low end.

One of the tools is a shielded loop for coupling the signal generator to the receiver by radiation. The other tool is a special tuning wand that shows which way to bend the capacitor plates for maximum output at any frequency.

The loop (Fig. 1) is made of 1/2-inch copper tubing bent into a circle 7 inches in diameter. Cut or file a 1/2-inch hole in the *outside* wall directly opposite the open ends (Fig. 1-a). Attach a 1-inch length of phenolic or polystyrene tubing to one of the open ends. Thread two full turns of good-quality insulated hookup wire through the tubing and

bring the wire ends out through the 1/2-inch hole. (Fig. 1-b). Slip the free end of the copper tubing into the open end of the insulating sleeve and fasten securely, leaving a 1/2-inch gap between the ends of the copper tube. Put a ground strap around the tubing near the 1/2-inch hole for the two lead wires of the loop winding.

The tuning wand is a 16-inch length of 3/4-inch plastic or phenolic rod or tubing. A closed loop of No. 14 bare copper wire, 6 inches in diameter, is fastened to one end. At the opposite end is a 3 x 4-inch bakelite plate, drilled to hold as many powdered-iron slugs as you can lay your hands on. The slugs can be threaded or cemented in place.

Clip the ends of the hookup wire to the signal-generator cable and ground the copper loop shield. Place the receiver about two feet from the loop. After a 10-minute warmup set the generator and receiver at the high frequency recommended by the set manufacturer and adjust the oscillator trimmer for maximum output. Retune the generator and

set to 1400 kc and peak the r.f. trimmer. Then change the generator to a lower frequency (say 1200 kc) and tune the receiver to the same point. Insert the wire-loop end of the tuning wand in the path of the signal between generator and receiver. If the output increases, bend the partially meshed split plate on the r.f. tuning capacitor *out* to reduce the capacitance. If the output drops when the loop is inserted, reverse the tuning wand and note the effect of the powdered-iron end. If this raises the output it means capacitance must be added. This is done by bending the split plate *in*. Follow the same procedure at as many points as you wish. When the r.f. tuning capacitor is correctly adjusted either end of the tuning wand will reduce the output.

Even better tracking can be obtained by repeating the procedure with the split plates of the oscillator section. This requires extreme care to prevent throwing off the high end, and should be done only *after the r.f. section has been tracked*.

—end—

SIMPLER FORMULAS

Most of us know and use the standard formula for X_c (capacitive reactance). It is

$$\frac{1}{2\pi (\text{cycles}) (\text{farads})}$$

We find this difficult for two reasons. A farad is not a practical unit, so we must always convert. Also, the factor 2π tends to muddle the rest of the equation. For these reasons I use an equivalent formula, simpler than the above, yet with almost the same accuracy. It is

$$160,000 / (\text{cycles}) (\mu\text{f})$$

The above is suitable for low frequencies when we deal with large capacitors. For high frequencies the following is more appropriate:

$$160,000 / (\text{mc}) (\mu\text{mf})$$

Just the other day I came across this

problem: "Find the reactance of .01 μf at 800 cycles." Using the first formula, I came up with the answer by mere inspection. It takes much longer the conventional way. Now try this one: 250 μmf at 3 mc. Again we have the answer almost immediately: 213 ohms.

In a similar way we can use an easier equation for frequency. It is

$$(\text{mc}) = \frac{160}{\sqrt{(\mu\text{mf}) (\mu\text{h})}}$$

For example, find the resonant frequency of 300 μh tuned by 340 μmf . The answer is 500 kc. Although we still need the square root, we have converted to practical units. Also, we have eliminated the awkward factor, 2π .—
I. Queen

—end—

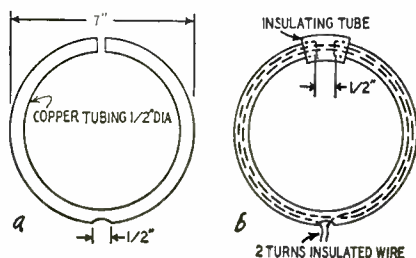

Fig. 1—(a) Shield for signal-generator loop. (b) Details of loop winding and radiating gap. Shield must be grounded.

Another look at
the unusual in modern
receiver circuits

By **ROBERT F. SCOTT**

Technical Editor

short circuits

IN MANY of the simpler TV sets the 60-cycle vertical sync pulses are used to develop a.g.c. voltage. This system requires a relatively long time-constant so the a.g.c. cannot follow rapid changes in signal strength like those caused by aircraft flutter. To overcome this disadvantage, several types of keyed, pulsed, or gated a.g.c. have been developed. The best-known form of keyed a.g.c. uses a pentode whose plate current is controlled solely by the peak level (sync pulses) of the composite video signal applied to its control grid. The plate current develops the negative voltage used for a.g.c. Variations of this circuit are used by several manufacturers.

The G-E circuit

The keyed-a.g.c. circuit used in the G-E 17C110 chassis is one variation of the basic system. The circuit is shown in Fig. 1. The grid and cathode of the 6AU6 keyer tube are connected across 3,000 ohms of the video-amplifier plate load. The voltage drop across this resistor biases the keyer tube to cutoff. The keyer-tube plate is connected to ground through a winding on the width coil and a 322,000-ohm resistor chain. Plate current does not flow until the positive sync pulses across the 3,000-ohm grid resistor coincide with the positive-going keying pulses injected into the plate circuit by the width-coil winding. The 6AU6 plate current which flows through the 322,000-ohm resistance is independent of plate voltage and entirely dependent on the peak amplitude of the signal appearing in the grid circuit. The a.g.c. voltage is tapped off at the junction of the 150,000-ohm plate resistors.

Some a.g.c. bias must be provided to protect the r.f. and i.f. tubes when no signal is received and the a.g.c. tube cannot conduct. This is obtained from the horizontal oscillator, which develops a large, stable, negative bias at its grid. The 470,000-ohm and 22,000-ohm resistors form a voltage divider across the horizontal oscillator grid circuit. About 0.6 volt for the a.g.c. line is taken from the 22,000-ohm tap.

The video amplifier is operated as a noise limiter. Its operating voltages are set so the tips of the negative sync pulses from the detector drive the video amplifier almost to cutoff. Noise pulses stronger than the sync tips are clipped slightly above the level of the sync tips.

The screen grid of the keyer tube is supplied from the low-voltage side of a 2,350-ohm dropping resistor for the plates and screens of the first and second video i.f. amplifiers connected to the a.g.c. line. When the incoming signal is weak, the i.f. plate currents are high and the dropping resistor decreases the voltage on the screen of the keyer tube. The reduced screen voltage lowers the gain of the keyer and decreases the a.g.c. voltage. This increases the gain of the second r.f. amplifier and the first and second video i.f. stages to compensate for the weak signal.

Du Mont keyed a.g.c.

The Du Mont keyed-a.g.c. system used in the RA-160 and RA-162 chassis consists of a 12AX7 dual triode and one-half of a 6AL5. See Fig. 2. The first section of the 12AX7 is the a.g.c. amplifier and the second section is the a.g.c. keyer tube or "gate." A portion of the composite video signal is taken off the plate of the 6AG7 video amplifier and fed to the grid of the a.g.c. amplifier. Direct coupling is used between the a.g.c. amplifier and the sync take-off point. The voltage across the 47,000-ohm resistor biases the a.g.c. amplifier grid. Additional bias which reduces the plate current nearly to cutoff is developed across the 820,000-ohm cathode resistor. The operating bias is set so the tube passes only the portion of the grid signal above the level of the blanking pedestal. Consequently only the sync pulses appear in the cathode circuit. The video information is eliminated so the a.g.c. bias is determined solely by the level of the sync tips.

Variations in the level of the r.f. signal applied to the receiver cause corresponding variations in the amplitude of the signal applied to the grid of the a.g.c. amplifier. Since the composite video applied to the grid of the a.g.c. amplifier is positive, an increase in its amplitude causes a greater voltage across the 820,000-ohm cathode resistor. A decrease in the amplitude of the grid signal results in a corresponding reduction in the cathode voltage.

This varying cathode voltage is applied to the grid of the a.g.c. gate tube through a low-pass filter consisting of 10,000-ohm and 1.2-megohm resistors and .02- and .03- μ f capacitors. The filter removes the sync pulses and passes only the d.c. voltage which varies in amplitude with the strength of the in-

coming TV station carrier.

A portion of the boosted B plus voltage is applied to the cathode of the a.g.c. gate through a voltage divider consisting of the 100,000- and 68,000-ohm resistors. The positive voltage on the cathode of the gate tube is considerably greater than the positive voltage on the grid so the tube remains cut off until a sufficiently large positive voltage is applied to the grid or a negative voltage to the cathode.

A sawtooth from the output of the horizontal oscillator is applied to the cathode of the gate tube through a differentiating network consisting of the 120- μ f capacitor, the 10,000-ohm AGC ADJUST control and the .01- μ f capacitor. This network modifies the sawtooth so the signal on the cathode of the gate tube is a small sawtooth with high-amplitude negative peaks as shown on Fig. 2. The amplitude of the signal applied to the cathode is controlled by the setting of the AGC ADJUST control. It is sufficient to make the gate tube conduct.

Since the amplitude of the cathode signal which causes conduction is constant, the signal at the plate of the gate tube is a negative-going sawtooth whose amplitude depends directly on the strength of the incoming r.f. signal.

The output of the a.g.c. gate is capacitance-coupled to the cathode of the a.g.c. rectifier. Negative voltage from the rectifier plate is applied to the grids of the first and second video i.f. amplifiers through filter networks. The available a.g.c. voltage is applied to a voltage-divider network consisting of two 100,000-ohm resistors in series between the rectifier plate and ground. The junction of these resistors is connected to a tap on the HIGH-LOW a.g.c. switch. When the switch is in the HIGH position, a portion of the a.g.c. voltage is applied to the first r.f. amplifier to prevent the tuner from overloading on strong signals. A small fixed positive bias (delay) is applied to the cathode of the a.g.c. rectifier to prevent a.g.c. voltage from being applied to the controlled stages on weak signals.

When the switch is in the LOW position, the r.f.-amplifier grid return is grounded through the 5.6-ohm resistor. The ungrounded end of this resistor is connected to ground on the sweep chassis through the cable between the sweep and signal chassis. The negative returns of the tubes on the signal chassis are grounded through this resistor. The voltage across it biases the r.f. amplifier when there is no a.g.c.

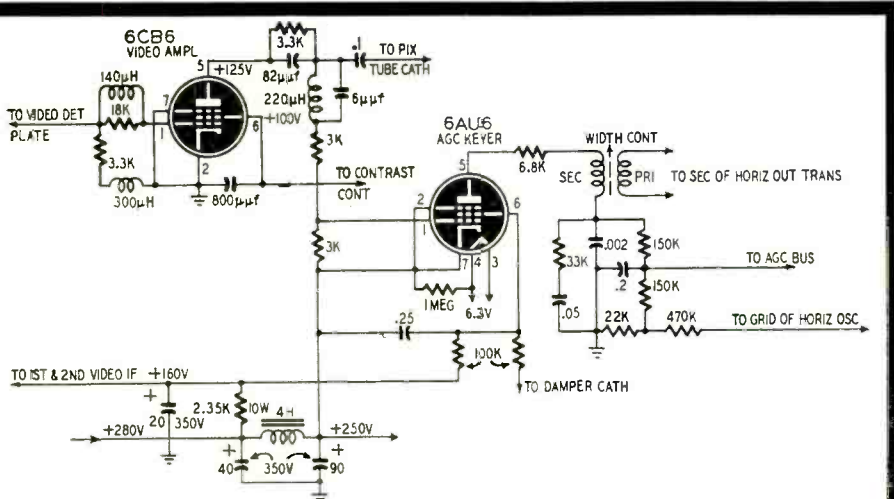

Fig. 1—The keyed a.g.c. circuit in G-E's 17C110 is similar to the basic system.

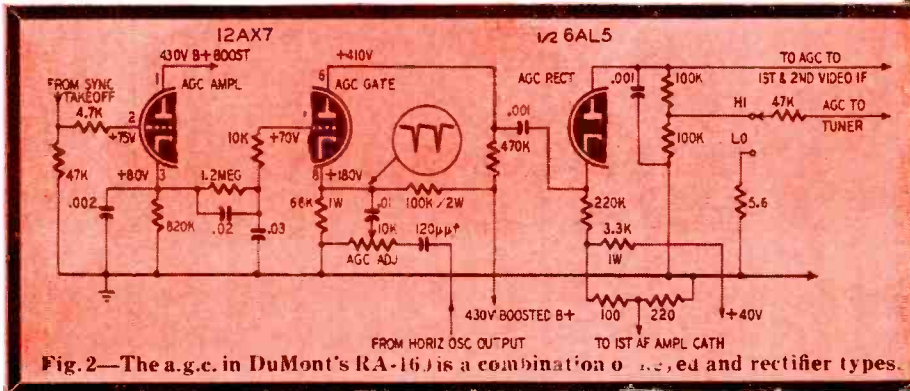

Fig. 2—The a.g.c. in DuMont's RA-16 is a combination of rectified and rectifier types.

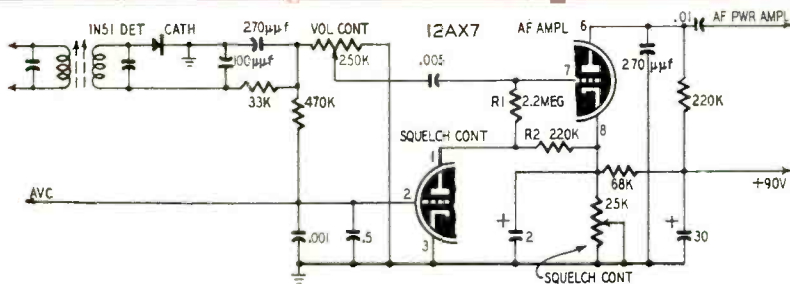

Fig. 3—Audio squelch circuit. A.v.c. cuts off squelch tube so amplifier conducts.

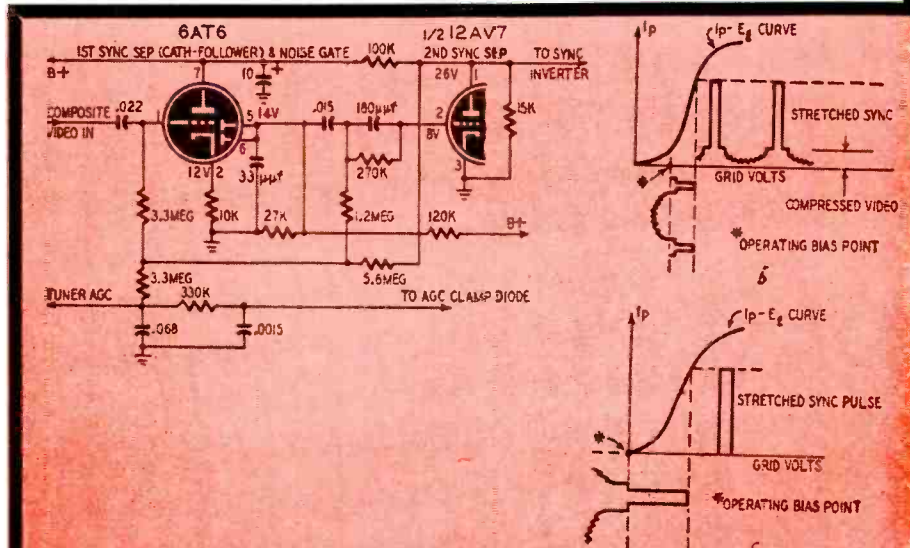

Fig. 4-a—Diagram of the Philco noise-immune sync circuit. The noise-gate diode limits noise to the level of the sync tips. Fig. 4-b—Operating curve of first sync separator. Bias point causes compression of video and stretching of sync. Fig. 4-c—Operating conditions of the 12AV7 second-sync separator circuit.

Monitorradio audio squelch

Receivers used by police, taxi operators, emergency services, etc., are often operated for considerable periods of time between received signals. When no signal is coming in, the receiver operates at full sensitivity and the resulting noise is distracting and annoying to the operators. Various squelch systems have been developed to silence the receiver until a signal is received. One of the simplest is used in the model AR-1 Monitorradio. The circuit is shown in Fig. 3.

In the absence of a signal, there is no d.c. voltage on the a.v.c. line. The squelch tube conducts heavily. The voltage drop across the 220,000-ohm squelch-tube load resistor R2 makes the plate end of the resistor negative with respect to the end connected to the cathode of the a.f. amplifier. Since the grid of the a.f. amplifier is returned to the plate of the squelch tube through R1, it is biased negatively by the voltage drop across R2. The voltage across R2 biases the a.f. amplifier to cutoff so the characteristic hiss and background noise cannot pass through to the speaker.

When a signal comes in, a negative bias voltage appears on the a.v.c. line and cuts off the squelch-control tube so there is no d.c. drop across R2. The a.f. amplifier now operates normally. The audio signal applied to its grid is amplified and passed on to the grid of the power-amplifier stage.

The sensitivity of the squelch tube is determined by the setting of the 25,000-ohm SQUELCH CONTROL. This resistor is connected as a bleeder on the B plus line supplying the plate of the squelch-control tube. The SQUELCH CONTROL is normally set to the point where the squelch-control tube plate voltage is low enough to cause the plate current to be cut off by the a.v.c. voltage developed by a signal just above the noise level.

Noise-immune sync circuit

TV receiver manufacturers are constantly seeking simpler and more efficient sync circuits which are relatively free from false triggering by noise pulses. One such circuit is used in late Philco receivers. One version of the noise-immune circuit is shown in Fig. 4. The circuit consists of a 6AT6 cathode-follower-type first sync separator, a diode noise gate, and one-half of a 12AV7 as the second sync separator. The fact that the first sync separator is a cathode follower may be difficult to follow without a breakdown of the circuit. If you have difficulty in understanding the circuit, redraw the 6AT6 as two separate tubes, with the triode section (pins 1, 2, and 7) in one envelope and the diode (pins 2, 5, and 6) in the other.

Now, add the 10,000-ohm cathode resistor and B-plus to the plate of the triode section. Add an output lead from the cathode (pin 2) of the triode. Looks like a cathode follower doesn't it? Well, it is.

Since pin 2, the cathode connection, is common to the diode and triode, extend the output lead to the cathode of the diode. Sketch in the diode plate-circuit components and then compare your circuit line-for-line with the diagram in Fig. 4. By now, you should see that the 6AT6 is connected as a cathode follower directly coupled to the cathode of a diode. Now, let's see how it works.

Composite video is tapped off the plate of the first video amplifier and is fed to the grid of the 6AT6 sync separator through a .022- μ f capacitor. This section of the 6AT6 is a cathode follower operated so the positive-going sync pulses fall on the linear portion of the I_p-E_g curve where they receive maximum amplification. The video information is handled on the nonlinear portion of the curve so it is compressed. The operation of this circuit is shown at *b* in Fig. 4. The stretched sync pulses and compressed video appear across the 10,000-ohm cathode load resistor. Since the cathode is common to the triode and diode sections of the tube, this signal is directly coupled into the diode section which is operated as a *noise gate*. This circuit limits noise pulses so their amplitude cannot exceed the amplitude of the sync pulses.

The noise-gate diode is operated with its plate only a few volts more positive than its cathode. Positive signals equal to or less than the amplitude of the sync pulses cause the diode to conduct so the output appears at the diode plates (pins 5 and 6). Signals (noise pulses) of greater amplitude than the sync pulses make the cathode more positive than the plates so the diode cuts off. The signal at the diode plates consists of stretched sync pulses, compressed video information, and limited noise pulses.

This signal is fed to the grid of the second sync separator through a .015- μ f capacitor and a 180- μ f capacitor shunted by a 270,000-ohm resistor. The 270,000-ohm resistor passes the low-frequency vertical sync pulses around the capacitor. The capacitor handles the higher-frequency horizontal sync signal.

The second sync separator (one-half 12AV7) completely separates the stretched sync pulses from the compressed video signal and blanking information. It operates with low plate voltage so a positive pulse equal to or greater than the amplitude of the blanking pedestal is required to make it conduct. The operation of the second sync separator is shown in *c* in Fig. 4.

The negative-going sync pulses which appear in the plate circuit of the second sync separator are fed to a sync inverter tube which develops the positive pulses required to trigger the sweep oscillators.

Some Philco sets use a modification of this circuit. One-half of a 12AV7 is the cathode-follower first sync separator. One triode section of a 12AU7 has its plate and grid strapped together to operate as the noise gate. The remaining section is the sync separator.

—end—

A FEW SIMPLE CURES FOR SUPERHET SQUEALS

By CHARLES ERWIN COHN

Continuous squeals (canaries) in superhet receivers are common, especially in small receivers, and the technician has developed his own methods of handling them. There is one type of squeal which may be found in high-gain receivers, and which may be very difficult to locate or cure. It is especially prevalent in home-constructed jobs. After building a sensitive superhet receiver, the constructor often finds strong oscillations which seem to defy every effort to clean them up. The most common cause of these oscillations is feedback from the second detector to the converter.

Feedback may take place through the wiring, by capacitive coupling between tube elements, or by radiation from the detector circuit picked up by the antenna.

Determine if radiation is actually the cause, by pulling out the converter tube. If the oscillation stops, this is the answer. However, if it continues, then the i.f. amplifiers are at fault. In receivers with a.v.c., the oscillation shows up as a periodic thumping.

Wiring pickup is the hardest to handle, and should be guarded against in the design. Lay out the set so that the converter and second-detector circuits are as widely separated as possible. In completed receivers the only remedy is to shorten all signal leads in the second-

detector circuit. Bypass all other leads right at the socket- or i.f.-transformer terminals. Use shielding in extreme cases.

Use metal tubes if possible, or install close-fitting, well-grounded shields over glass types.

If oscillation occurs only when the set is tuned to a signal near the intermediate frequency, the feedback is probably through the antenna or r.f. circuits. Check this by disconnecting the antenna. This trouble is especially noticeable at the low-frequency end of the dial in broadcast receivers using 455 kc i.f. In these cases, try a lower i.f., and check for i.f. radiation from external leads such as the line cord, power-supply cable, and speaker or headphone cords.

In converters using a separate oscillator with oscillator voltage taken from plate or cathode, the lead to the converter is a common source of pickup. Moving the takeoff to the oscillator grid may help, because of the low impedance of the oscillator tank to i.f. signals.

Anyone planning to build a high-gain receiver should note these ideas. A careful layout with plenty of separation between front and rear ends, complete shielding (including the tubes), and complete bypassing and decoupling of all r.f. and i.f. circuits will go a long way toward eliminating oscillation troubles.

—end—

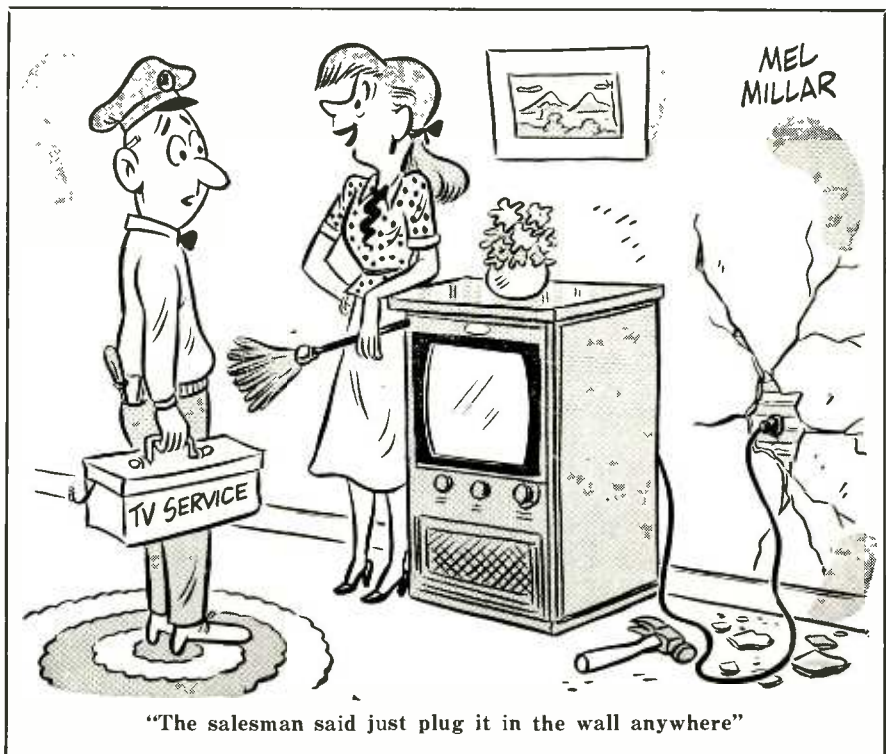



RADIO SERVICING is a BUSINESS

Make your rates and stick to them—forestall callbacks and customers' gripes with adequate records

By J. W. ESSEX

"MANY are called but few are chosen," goes the old scriptural saying. It applies definitely to the success of a radio service business. We have all seen service shops enjoying what looked like an easy living; but when the sheriff arrived to lock up their doors you realized that someone slipped somewhere.

The average technician is not to blame for failing to recognize the importance of sound business methods, because many radio schools fail in this one important point. The technical training in my first correspondence course was more than adequate, but the business end was sadly neglected. I remember writing to them after graduating to ask for information on making out bills for service under the "rate system." When I finally received the information, it was like sunshine breaking through after a rainy day. I found their little rate charge book as valuable as the whole technical course. *But I did not get it until I wrote and asked for it.*

That is just one example of how lightly the most important phase of radio servicing is skimmed over. The worst of it is, lack of training in business methods usually leads to timidity in asking enough for your efforts. At the opposite extreme is the error of charging too much in an effort to break even. This will make you lose out to competitors who have somehow managed to strike a happy medium.

The Philco people have compiled a Standard Radio Manufacturer's service rate as a basis for charges. A system set up by the National Radio Institute

Alumni Association in Washington is patterned along the same line. The two systems are basically similar. NRI differs in charging an initial fee to cover the work involved in checking tubes, inspecting chassis, removal and installation in cabinet (and talking to the customer, which is always extra time). *It is important to your monthly balance sheet that you get paid for these extras.* This is what makes the difference between a good income and just a fair one.

(Editor's note: Service technicians are advised to write directly to these organizations for copies of current rate schedules, since these may vary with location and season.)

Don't jump to conclusions about your own method of running your business. I agree that what constitutes a proper return for effort spent in diagnosing and remedying faults in radio circuits is always open to debate. For example, I have modified the listed charges for installing capacitors when more than one is replaced. My charge for the first capacitor is \$3.00; for the second \$1.50, and 50 cents each for any others required. The final charges are still reasonable for this part of Canada (they would probably be higher in "The States"), but I have maintained the rate system for figuring bills.

It is important to record each step of your work and the charge for it; you will find your initiative automatically sustained because there is compensation for your extra effort. Gone will be those annoying "call-backs" where you were satisfied with a quick repair (and a seemingly quick dollar).

Your job will bring far more satisfaction to you and your customer when it doesn't bounce back the next day.

Keeping a record of all work done on each set will pay off in another way. As time goes on and some of your early repairs return for checkups, you can easily refer back to what was done earlier in the matter of replacements. The record also provides a source of names for a mailing list. If you guarantee the parts you put in a set it is imperative you have a complete record in case the set is returned under the guarantee. It pays to have proof that the tube that popped was not one that you put in, but one of the older ones, so you can sell the customer a new tube and still keep his good-will. To this end, it is wise to list the condition of all tubes on your bill. You will get that tube sale sooner or later.

I have been using the NRI rate system for over two years (with only minor modifications) and find it more than satisfactory. It is true that rate charges will have to stand the test of competition. Each locality will have its own peculiarities, and your competitor down the street will have some influence on your final rate card. But once your rates are set, *stick to them*, and soon you will be as much at home in making out bills as you are in getting the radio repaired.

Concentrate on doing good work, and the rate card will take care of the financial end for you. Good work will encourage more business, and with a proper set of rates, you can always come out in the black at the end of the month.

—end—

ELECTRONICS and MUSIC

PART XXVII

Obstacles and opportunities
in building an organ
yourself—last installment
in this series.

By RICHARD H. DORF

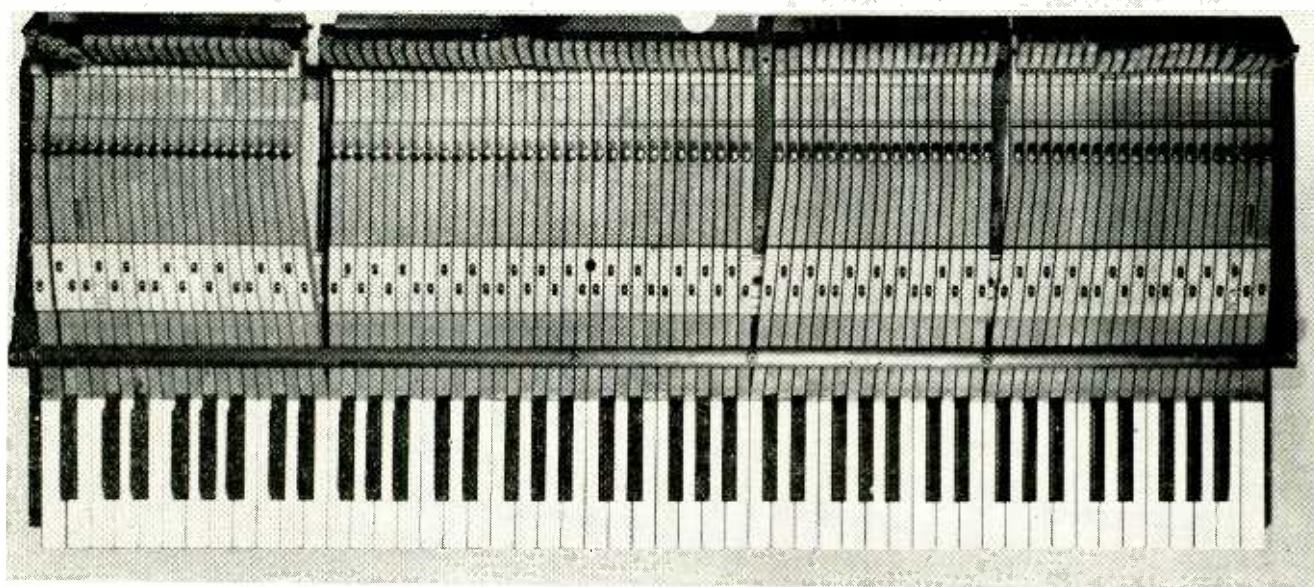

DURING the two years and more that this series of articles has been running in RADIO-ELECTRONICS the writer has received a good deal of mail from readers who have problems of one sort or another in designing and building electronic musical instruments. The general trend of the inquiries indicates that certain problems are widespread. This article—the final one of the present series—will attempt to give some general conclusions the writer has reached on constructing electronic musical instruments.

It is not surprising that among the many devices made possible by electronics, musical instruments rate high as construction projects. The possible reward is very attractive—a means of musical expression far more versatile than any standard instrument except the pipe organ—and there seems to be a highly intriguing quality about the idea of making music from resistors, capacitors, and tubes. The reward, however, in common with most other rewards in this world, must be earned. And the earning process is long, painstaking, and expensive. In an electronic organ—the most popular project—the basic fact that confronts one is that—at

the very least—61 separate tones must be generated, and they must be available in any combination. No matter how hard we may try to circumvent it, 61 or more individual tone generators must be built. True, there have been a few patents on ways of making fewer generators do the job, but they are not particularly practical. Witness the fact that no commercial instruments (except the simplified Hammond Chord Organ) have taken this path to economy. Sixty-one of anything involving vacuum tubes is a lot, especially when this only starts the job—there is still the problem of what to do with the tones once you have them!

The keying system is one of the worst headaches, and not just because of the minimum of 61 switches per manual. Audio circuits have the perverse quality of clicking and popping when keyed, and of sounding like code-practice oscillators when keying is practically instantaneous.

All in all, building an organ is not a task to be considered lightly. No matter what the design, it entails many hours (hundreds of hours is more like it) of hard labor, much head-scratching in design, unavoidable hours of experimentation, and enough dollars to cover the

cost of an enormous list of parts.

The writer has given this warning to all the many correspondents who have written "Please send me a complete set of instructions for building an electronic organ." No "complete set of instructions" is available, either from this source or any other source known, though a complete organ has been designed and is now under construction. To answer the obvious question, this design will be published in full some time after the end of the summer and complete sets of construction prints will be offered to those who want them. There are too many problems involved in a genuinely musical instrument to allow anyone with a clear conscience to offer a design that has not been proved.

Deciding on requirements

This series started 27 months ago with a statement to the effect that simply assembling some oscillators which have the requisite frequencies does not yield a musical instrument. Keeping that in mind, let us try to decide what the end results and means should be for an individual who wants to construct an electronic organ.

The first requirement is a set of tone

generators. It is desirable to have at least 5 octaves (plus the top C) of keys, establishing 61 notes as a minimum. It is best to have an extra octave—a 16-foot register—at the bottom to give a good bass foundation, whether or not a pedal clavier is included. It is possible to get by without an extra octave on top (as in the Baldwin model 5) and to include a 4-foot register by having the last octave of keys repeat the notes of the fourth octave in the high register. But if it adds no excessive complication, the extra octave is useful. With a total of seven octaves and top C we have 85 notes to generate; without the top octave, 73.

It is not easy to use 73 individual,

carefully, either by ear—counting beats until the new oscillator is right on the nose—or with an oscilloscope Lissajous pattern. Let the oscillator run for several hours, then check its frequency again. Turn it off and let it cool, then turn it on; after five minutes or so check it again. In each case the pitch should be so close to the reference that the note is musically acceptable. The figure of $\frac{1}{4}$ of 1% accuracy is the *outside limit*, and it means 1 cycle permissible error at 400 cycles or 10 cycles at 4,000 cycles, which is not much! If the first design does not measure up, discard it and try again. Never skip this tryout procedure! You may copy someone else's design electron for elec-

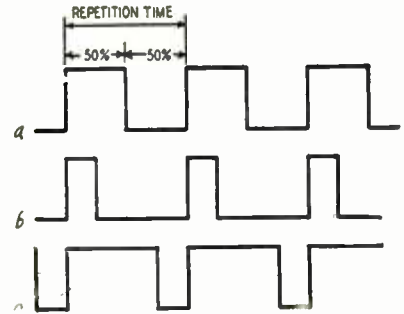
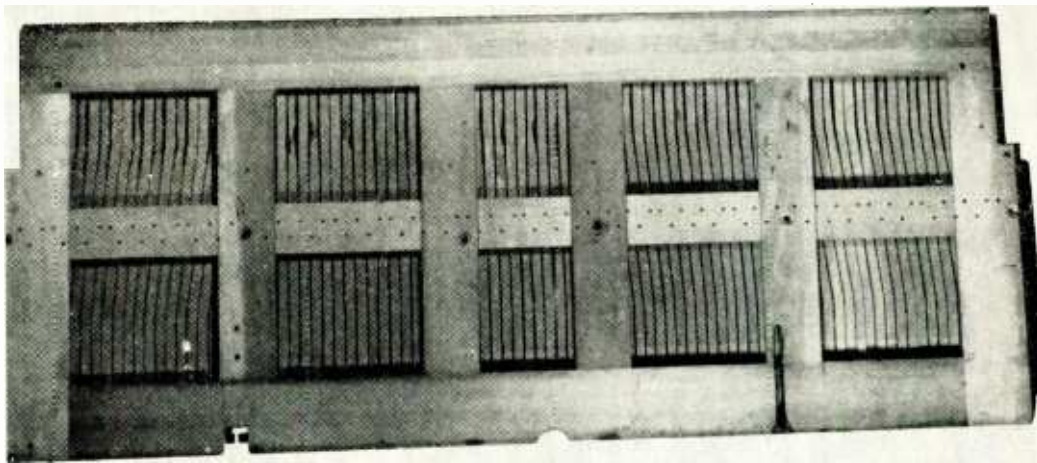

Fig. 1—(a) Symmetrical square wave—characteristic of woodwind tone. (b and c) Preferred waveforms for deriving a wide variety of instrument tone colors.



Top and bottom views of a high-quality piano keyboard easily adapted to electronic-organ use. The felt hammers are removed and the actuating arms cut down to just the length needed for the key switches.

unsynchronized oscillators, as in the Consonata, because of tuning difficulties and drift. Usually the logical decision is octave strings, with 12 sets of frequency dividers or multipliers, each set generating as many notes as there are octaves of generators in the organ—from 5 to 7. More than seven (used to provide 2-foot ranges and higher) rarely contribute enough to the musical results to justify the effort.

Each divider string must begin with a sure-fire self-excited oscillator stable within $\frac{1}{4}$ of 1% accuracy or better. Design should begin with laboratory-bench experiments with various oscillator types. A reference source for tone pitch is a necessity, since no variable-frequency audio test generator is accurate enough. A newly-tuned piano is good; a Hammond organ is even better. A Stobocon is best but not generally available. A good-quality harmonica can be used if it is first checked with a well-tuned piano. This reference source will provide the essential accuracy for final tune-up. For the design procedure it need only be stable, not necessarily exactly on pitch.

After a sample oscillator is built (breadboard style is recommended) it should be tuned to coincide with a note from the reference source. Tune very

tron and still have unstable oscillators.

Before deciding on the system of dividing or multiplying frequencies, the other organ requirements must be outlined. First, what method of tone coloring will be used? If harmonic synthesis (Hammond-Organ style) is wanted, then each generated tone must have sinusoidal waveform, which is not easy with oscillators that must be synchronized. Perhaps the most practical way to obtain sine waves with synchronized oscillator strings is to generate some other kind of waveform and then use a low-pass filter in the keying system between each octave group of tones and the rest of the system. This, incidentally, will kill key clicks as well.

You may decide to use a phonic-wheel system, as in the Hammond, but here again bench experiments must be made with sample tone wheels and pickup magnets to determine the best metal and the precision with which each wheel must be made. This method is suitable only for people with marked mechanical-design ability and the necessary tools and facilities.

If the *formant* method (used in the Baldwin and Minshall organs and, in simpler form, in the Solovox and Organ) is chosen, the tones must have a complex waveshape, the more complex

the better. Sawtooth waves are best because they contain a smooth progression of even harmonics, but square waves are useful too. The pulse width should be greater or less than 50 percent of the repetition rate to avoid giving all tones a stopped or woodwind quality. (See Fig.1.) Square-wave tones can be obtained from multivibrators and flip-flop circuits, while sawtooth signals usually entail relaxation oscillations of one kind or another.

You may prefer a formant and mixer system like the one in the Consonata. The Consonata uses individual oscillators which yield both sine and pulse signals. This can be done with synchronized strings by using octave filters as suggested above to obtain sine waves after keying, and by using separate key switches followed by differentiators (high-pass filters, effectively) to obtain sharp pulses. Don't use frequency dividers or multipliers which will work only at a single frequency. Any system, even though it is for only one note of the 12, should function well over a range of at least three semitones. Otherwise it may as well be discarded.

The keying system is an important decision. In a pipe organ each stop is normally available in a certain register—4-, 8-, 16-foot, etc.—and couplers are

provided to give the same stops in other registers as well. The Baldwin organ is an electronic example of this practice. It is also feasible to key all tones at one or more registers and have stop filters passing tones of any register selected, as in the Minshall.

Key click is the most serious problem in any keying design. The problem has never really been solved in an ideal way, but probably the best method (though not the easiest or cheapest) is Baldwin's variable-resistance key switches. Unfortunately, these switches are not easy to make and can be obtained only from Baldwin, though they may be available as replacements from some Baldwin dealers. Assuming there is no d.c. being keyed, the clicks take place in a high-frequency region somewhat above the frequency of the highest fundamental. They may be eliminated by octave filters, as in the Minshall, though this also does away with some of the harmonic content of the signal waveform. Vacuum-tube keying is practical from the schematic viewpoint but means the addition of at least one tube for each section of each key switch assembly. Vacuum-tube keying requires at least a 2-section R-C delay network at the grid. The rise time must be rather slow to avoid the thump caused by plate-current rush unless well-balanced push-pull tubes are used.

Tone-coloring methods have been described in this series and the one chosen is a matter of preference. The designer should listen to good pipe organs and recordings and judge results by ear.

Amplifiers should have exceptional power-handling capacity in the low-frequency region. This means good output transformers and plenty of negative feedback. Twenty watts is about the minimum power output for any organ, even in small rooms. Speaker systems should have good bass characteristics; it is usually best to use one to four heavy speakers with at least 12-inch cones. Tweeters are rarely necessary, though they may add something to a good instrument. Intermodulation distortion must be kept low, for sustained multiple tones produce very annoying beat tones in a nonlinear system. Frequency non-linearity, of course, will change the tone colors of any kind of organ, since it has the effect of a formant filter.

Materials and construction

Every organ includes a number of purely mechanical complications, the most obvious of which are the keyboards or manuals. The simplest solution is to get a second-hand pipe-organ console and build everything inside it. The keys, action, pedals, housing, stop tabs, and so on, are already provided. Consoles are not particularly hard to find, especially in the larger cities. Look up organ repairmen in the telephone book and ask them to notify you when they get a console. Most of them will have one sooner or later. Another source is a local dealer in electronic organs; he often will sell or give away

the pipe or reed organ he replaces.

The console should be examined carefully to see that the action is in working order or easily repairable. Damaged key ivories are easily replaced either with new ones or those peeled from another used keyboard. The pedal action should also be examined. If possible, obtain a console with at least as many stop tablets or knobs as your design calls for. Extra ones are not easy to add, especially if good appearance is a factor. A combination action is a desirable feature; the pneumatic actuators usually can be removed and solenoid actuators substituted. Reed-organ consoles are acceptable, but usually require more work for adaptation. The keys are usually much longer than necessary, since they had mechanical work to do rather than simple electrical contacting, and the case may be deeper than required. The case can be cut down, of course.

A console can be built by a handy woodworker, the only outside requirement being the keyboard. Here again an organ repairman may be able to supply a keyboard from an old organ or harmonium. Be careful to get a C-to-C keyboard, since some harmoniums have F-to-F manuals. The photographs show top and bottom views of a Steinway piano keyboard purchased for very little from a piano-repair concern. The keys are in perfect condition, and were cut, after the photo was taken, to eliminate the hammers and pins, leaving only enough behind the pivots to actuate switches.

Key switches may be made in several ways. Possibly the easiest is to purchase flat relay-contact blades and assemble them in the desired positions, either under the key fronts or above the rear ends of the keys. Guardian Electric Manufacturing Co. makes a contact parts kit (No. 200-3) containing an assortment of blades, contact rivets, washers, and spacers, which is useful for this purpose. Springs and contact strips also may be used, as in the Thyratone. Nickel and phosphor-bronze contact spring wire, available from organ repair men, also may be used to make light and small contacts.

Generator systems should be built and mounted so they can be removed in sections for servicing and adjustment. The logical arrangement is to put the string for each note on a separate chassis, making 12 in all. The chassis need not have sides and skirts; often a simple flat piece of metal makes a fine chassis for this purpose. It is especially worthwhile to mount the parts in such a way as to make it possible to reach them while the organ is operating. Many experiments with valves and circuits undoubtedly will be made after the instrument is complete, especially in the tone-coloring section.

The *EXPRESSION* pedal or pedals and the *CRESCENDO* pedal, if any, are important design points. Ordinary radio volume controls are not suitable, even though it may be possible to link them to the pedals. The *EXPRESSION* pedal undergoes hundreds of times as many

operating cycles as radio or amplifier controls and must be especially rugged. Whatever control is used must at least be a heavy wire-wound unit. The best type is the contact-stud variety, like a broadcast attenuator, available from General Radio, Daven, Cinema Engineering, and other companies. High-impedance types are usually undesirable because the necessary lines cause high-frequency loss and because any contact disturbance is more obtrusive in a high-impedance circuit. The expression control must not bring the volume down to zero in the minimum position. A range of 30 db or so is sufficient. At the same time the instrument must have some kind of preset volume control so that the maximum volume can be adjusted to suit the room and the listeners.

Separate tone cabinets are superior musically to having the speaker in the console. A speaker cabinet can be designed for good baffling and preferably should be placed in a corner of the room or auditorium, with the speakers facing the corner for good sound dispersion. A better installation method is to have a hard-walled organ chamber, perhaps 10 feet square or more, with the speaker cabinet concealed within it and louvers opening into the auditorium. Excellent results may be obtained also by placing several separate speakers at intervals along the front of the room, but they must be correctly phased to prevent interference.

Answers to some questions

In closing this series it might be well to reply in print to a few of the most-often-asked questions received by the writer. A frequent one concerns making this series material into a book. It is probable that the material, expanded and rearranged, will be published in book form. If and when that is done, announcements will be made.

Requests for full building plans for an organ must be met by a statement that no such plans exist, though they are now in preparation.

Many correspondents ask for more construction details of the commercial instruments described in this series, especially with respect to exact specifications of coils and the like. The descriptive articles were not meant to be construction articles, though the material in them furnishes some excellent design hints. Every scrap of information the manufacturers could be prevailed upon to furnish was published; it is impossible to furnish more.

In concluding the series, the writer would like to express his gratitude to all the readers who wrote in—for their interest and their comments. While the field of electronic music does not interest everyone in electronics, its devotees are indeed enthusiastic. The instruments now available have only scratched the surface of possibilities; in a few years the electronic organ may be as common as the piano in the homes of America, and readers of this series may be among those responsible.

—end—

TAPE RECORDING

By I. QUEEN
Editorial Associate

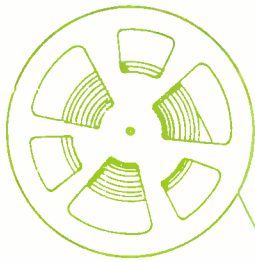

Tape-threading and transport systems—checking head wear—vital maintenance

PART II

THE tape mechanism is composed of motors, pulleys, cams, levers, and clutches to pull, control, and guide the tape through the machine. Moving parts mean wearing parts, so periodic maintenance is needed. Normally this includes regular cleaning away of dirt and dust, keeping all parts properly lubricated, and replacing worn parts. Most machines are very rugged and seldom need major repairs or replacements. The manufacturer's service data should always be consulted before attempting a major job on the mechanism. Most repairs can be made readily by a technician with average mechanical ability, sufficient service information, and a knowledge of recorders.

During recording and reproducing the right-hand pressure arm holds the tape against the capstan by a pressure roller. The capstan pulls the tape past the heads at uniform speed. The felt pad holds the tape against the head. The pressure arm shown at the left holds the tape firmly against the erasing head during recording. Recorded material is erased automatically before a new recording is made.

Both arms are released during rewind (This is the position the photo shows them in). This leaves the tape free to move rapidly from one reel to the other. Rewind speed may be as fast as 10 times normal (or capstan) speed.

Tape transport

Threading a tape is much easier than threading a film projector. In many types of recorders—such as the Brush in Fig. 1—the reels are put in place on their spindles and the tape is simply dropped into the threading slot. It is automatically positioned beneath the cover plates. These protect the mechanism and keep out dirt. Fig. 2 is a view beneath the cover plates of a typical recorder. Coming off the feed reel (not shown) the tape passes first around the erasing head and then the record-playback head. Then it comes around the capstan and is taken up on the other reel (not shown).

Routine maintenance

After prolonged use, contact surfaces of the erase and record heads accumulate tape particles, dirt, and dust. They should be wiped clean periodically with a dry cloth. If the dirt is hardened, remove it with carbon tetrachloride on a cotton swab at the end of a toothpick or on a folded pipe cleaner. Wipe the surfaces dry after cleaning. *Never use a brush or sharp instrument on the head surfaces.*

The capstan and other metal moving parts may also be cleaned with carbon-tet. *Keep this solvent away from the tape and from rubber surfaces.*

Gears, pivots, bearings, and sliding surfaces should be covered with a thin

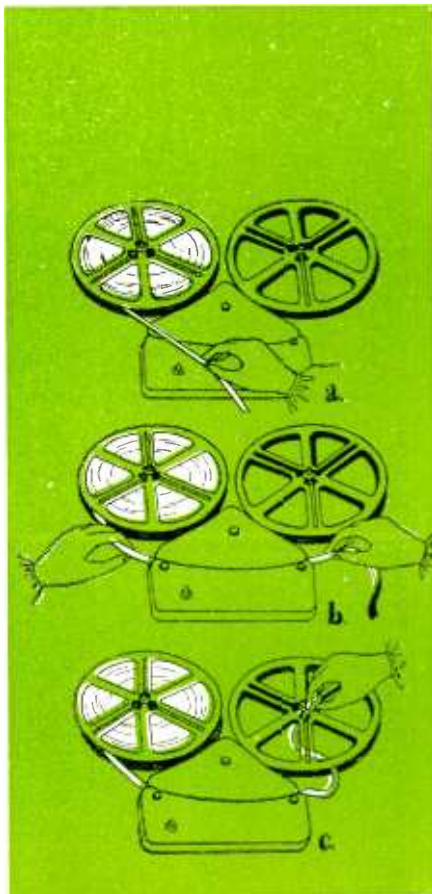

Fig. 1—Semi-automatic tape threading in Brush "Soundmirror" recorders. (a) Tape leader is pulled out. (b) Leader dropped in tape guide slot. (c) Free end locked in takeup-reel perforation.

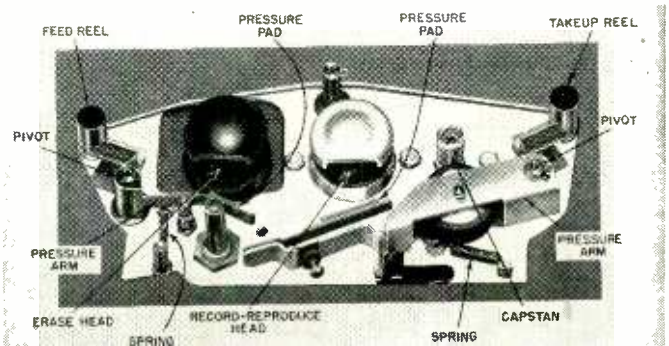

Fig. 2—Brush tape-transport mechanism. Functions of parts are explained in text.



Three modern portable tape recorders: Wilcox-Gay (left); Web Cor "Electronic Memory" (center); Brush "Soundmirror" (right). Wilcox-Gay has push-button tape control. All three types have built-in playback amplifiers and loudspeakers.

film of lubricant. Most machines do not need added lubrication for extended periods of time. However, when the parts have been disassembled for replacement or repair, they may be wiped clean of dirt and rubber dust from the belt and then relubricated. Lubrication is also needed whenever any moving parts become noisy or show signs of binding.

Never oil the capstan, motor shaft, or rubber wheel surfaces. Some motors never require oiling. Brush Development Co., recommends oiling its recorder motors once every three months with SAE No. 20 oil. They also suggest a thin coat of light oil for all moving and sliding parts (after wiping free of dirt and rubber dust). Oilite bearings, used in many models, seldom require lubrication. Always consult service data for specific instructions.

Eicor, Inc., suggests the following lubricants for its machines:

Rotating shafts (when being replaced or reassembled)—

Wipe with lint-free cloth or paper and oil lightly (2 or 3 drops) with Kensington No. 9 spindle oil.

Felt washers on takeup and rewind drums—

Sta-Put oil No. 360. Saturate washers, then remove as much oil as possible by pressing against cloth or absorbent paper.

Mechanical linkages—

Sta-Put No. 18-H at points of friction. Lubricate lightly.

Head adjustments

After prolonged use, the erasing and recording heads show signs of wear and the h.f. response begins to drop off. Fig. 3-a shows how the magnetic gap widens, and 3-b is an exaggerated end view. Note how a groove is worn into the head surface.

The width of new tape normally varies between 0.244 and 0.250 inch. If a relatively wide tape is threaded on a worn head, it will not fit the groove (Fig. 3-c). The h.f. response will be reduced and the tape may be damaged. To prevent this, the head surface may be restored by *lapping*.

Audio Devices, Inc., recommends a Belgian water stone or lightly oiled Arkansas stone. Use only the lightest touch. Lapping prolongs the life of

head and tape, but eventually the head will have to be replaced.

When a new head is installed, it should not be tightened in place until properly aligned. Its position is correct

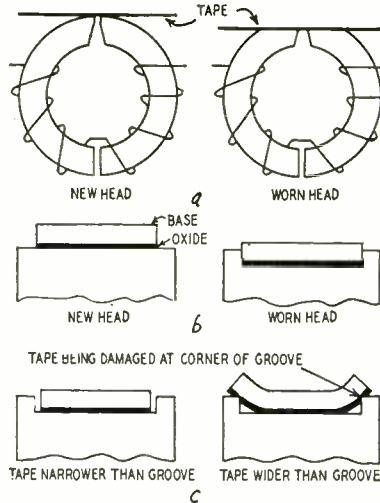

Courtesy Audio Devices, Inc.

Fig. 2—Effects of tape friction against soft-metal pole pieces. (a) Side views show how wear widens magnetic gap, cuts h.f. response. (b) End view of tape shows groove worn in head with prolonged use. (c) Normal variations in tape width may cause damage from groove edges.

when it provides maximum signal and minimum noise. The head should be rocked from side to side while a test tape is pulled through the machine. Output will be maximum when the magnetic gap is perpendicular to the tape. Some machines have a movable piece of mu-metal behind the head or on its pressure arm. This metal is tightened in the position at which least hum is heard. (This hum is often generated by the motor field.)

Correct head positioning is essential for highest fidelity. In broadcast stations the head is realigned daily for maximum output while a standard test tape runs through the recorder. As mentioned previously, a worn or poorly adjusted head shows up in loss of h.f. response.

With a properly balanced erasing circuit, hiss will be at a minimum. The erasing head may be checked from time to time for correct h.f. current and voltage as specified by the manufac-

turer. A magnetized head may generate considerable noise. *Keep all magnets or magnetized tools away from the heads.* A head may be demagnetized by inserting it in a coil carrying a.c. Remove slowly while current continues to flow. Some manufacturers recommend periodic head demagnetization to maintain a low noise level.

After several hundred hours use, pressure pads may need replacement. These may be attached with a quick-drying cement. After replacement, the pad pressure should be checked against service data. Insufficient pressure causes loss of h.f. because the tape does not contact the head as it should.

Mechanical troubles

In several respects *mechanical* troubles require a different procedure than *electronic* breakdowns. The mechanical defect is often easier to locate. For example, mere inspection may disclose a loose spring, bent lever, or worn cam. On the other hand, defective mechanical parts are generally more difficult to remove and replace. Removal of a shaft or lever must follow definite service directions and a study of an "exploded view" diagram.

Mechanical parts should be replaced with identical components. Most manufacturers design and make parts for their own machines, so substitutes are seldom available.

Often it is more convenient to replace

TABLE I
RECORDER TROUBLE CHART

Trouble	Cause
Distortion	Incorrect head adjustment Dirty record-playback head Incorrect h.f. bias Incorrect pad pressure Overmodulation during recording Equalizer defect Worn head
No erase	Dirt on head Insufficient erasing current Low pad pressure
Weak output	Incorrect head adjustment Low modulation during recording Incorrectly wound tape
Wow	Defective capstan or drive Bent reels Too much pad pressure Oil on capstan or drive
Noise, hiss	Magnetized record head Misadjusted mu-metal shield Unbalanced erasing circuit

an entire subassembly than individual parts. This saves considerable repair time and usually guarantees more satisfactory performance.

As with the electronic circuits, each tape mechanism differs in some ways from others. Some manufacturers include special mechanical features to simplify the machine and perhaps reduce cost. Others include features for more convenient operation, increased efficiency, or improved performance. These special features, rugged construction, improved performance, all determine final cost.

Tape speed is an important considera-

tion. Some machines have two or even three speeds. Low speed is desirable for lengthy speech programs. High speed is necessary for high-quality music.

Small machines generally have a single motor. Others include two or even three motors to distribute the load and assure minimum speed variation. The better machines have a wow of less than 0.5%. The Web Cor 210 has two separate motors, two separate drives, and associated parts. One motor drives the capstan only. The other controls the takeup and may be switched to either reel depending on the direction

of tape travel desired. This model also has two separate recording heads. Either track may be used without re-winding the tape.

Push-button control is used on some recorders, among them Wilcox-Gay and Revere.

A trouble-shooting chart appears in Table I. It does not include ordinary amplifier defects.

Tape data

Many companies sell magnetic tape. Some are listed here, together with their trade-names.

- | | |
|----------------------------|--------------|
| Amplifier Corp. of America | Magneribbon |
| Audio Devices, Inc. | Audiotape |
| Brush Development Co. | Magic ribbon |
| Minnesota Mining & Mfg. | Scotch |
| Reeves | Soundcraft |
| Webster-Chicago | Web-cor |
| Permo, Inc. | Permo |

A red-oxide (medium coercive-force) coating is recommended by practically all recorder manufacturers. This coating is available on either a paper or plastic base. The latter is more expensive but has a noise level about 10 db lower and is more durable.

Tape is always run with the uncoated side (shiny on plastic; grey or brown on paper) away from the erasing and record-reproducing heads. Therefore the tape winding depends upon whether the feed reel unwinds clockwise or not and whether the tape passes over or under the heads. Type A wind means that the tape is wound with coating toward the reel center. Type B has the coating away from the reel center. Table II lists a number of tape-recorder manufacturers and the winding type required for their products.

Fig. 4 shows the four steps needed to splice tape. This method assures a noise-free splice that will not come apart. The tape ends are cut at about a 60-degree angle, using an unmagnetized pair of scissors. With uncoated side up, they are then aligned without overlapping and without space between them. Next, splicing tape (for example, Scotch No. 41) is wrapped around the ends. Finally the edges are trimmed near the splice (dotted lines).

Tape should not be subjected to high temperature or humidity. Room temperature and 40-60% humidity are recommended. Tape stored for longer than six months should be rewound before playing. This safeguards against any tendency for adjacent layers to stick together. When tape is to be stored for five years or longer, a movie-type can is suggested.

For convenience and protection special leader and timing tape may be added at each end of a roll. Scotch No. 43 is a tough, plastic-treated, white-paper tape excellent for the purpose. It is printed in alternate sections of plaid and white (Fig. 5). The tape serves a triple purpose: It times the interval between recorded sections. (Each plaid or white section corresponds to 1 second at 3.75 i.p.s.) Finally, the white sections may be labeled in ink to identify recordings.

—end—

**TABLE II
TAPE WINDING IN COMMERCIAL RECORDERS**

MANUFACTURER AND MODEL OR TYPE OF TAPE RECORDER	B	A
Ampex — Models 400 and 300C	<input type="checkbox"/>	<input type="checkbox"/>
Amplifier Corp. — All "Twin-Trax" Models	<input type="checkbox"/>	<input type="checkbox"/>
Ampro Corp. — "Ampro-Tape"	<input type="checkbox"/>	<input type="checkbox"/>
Bell Sound Systems — "Re-Cord-O-Fone"	<input type="checkbox"/>	<input type="checkbox"/>
Berlant Assoc. — "Concertone"	<input type="checkbox"/>	<input type="checkbox"/>
Brush — "Soundmirror"	<input type="checkbox"/>	<input type="checkbox"/>
Califone Corp. — "Dynacord"	<input type="checkbox"/>	<input type="checkbox"/>
Crestwood — "Magictape"	<input type="checkbox"/>	<input type="checkbox"/>
Eicor — Model 115	<input type="checkbox"/>	<input type="checkbox"/>
General Industries — Tape-Disc Recorder	<input type="checkbox"/>	<input type="checkbox"/>
Fairchild — Console Models	<input type="checkbox"/>	<input type="checkbox"/>
Macon Electronics — "Musictape"	<input type="checkbox"/>	<input type="checkbox"/>
Magnetic Recording Ind. — VM-55, VM-56, VM56SS	<input type="checkbox"/>	<input type="checkbox"/>
Mark Simpson — "Masco"	<input type="checkbox"/>	<input type="checkbox"/>
Magnecord — All Models	<input type="checkbox"/>	<input type="checkbox"/>
Operadio — "Du-Kane"	<input type="checkbox"/>	<input type="checkbox"/>
Pentron — All Models	<input type="checkbox"/>	<input type="checkbox"/>
Permoflux — "Permoflux Scribe"	<input type="checkbox"/>	<input type="checkbox"/>
Presto — All Models	<input type="checkbox"/>	<input type="checkbox"/>
Rangertone — Models R-5P and R-5C	<input type="checkbox"/>	<input type="checkbox"/>
RCA — Models RT-11A and RT-12A	<input type="checkbox"/>	<input type="checkbox"/>
Revere — All Models	<input type="checkbox"/>	<input type="checkbox"/>
Sonar — Model PTM	<input type="checkbox"/>	<input type="checkbox"/>
Stancil-Hoffman — "Minitape" and Model R-4	<input type="checkbox"/>	<input type="checkbox"/>
Universal Electronics — "Reelst"	<input type="checkbox"/>	<input type="checkbox"/>
Webster Chicago — "Web Cor"	<input type="checkbox"/>	<input type="checkbox"/>
Webster Electric — "Ekotape"	<input type="checkbox"/>	<input type="checkbox"/>
Wilcox-Gay — "Recordio"	<input type="checkbox"/>	<input type="checkbox"/>

Courtesy Audio Device, . . .

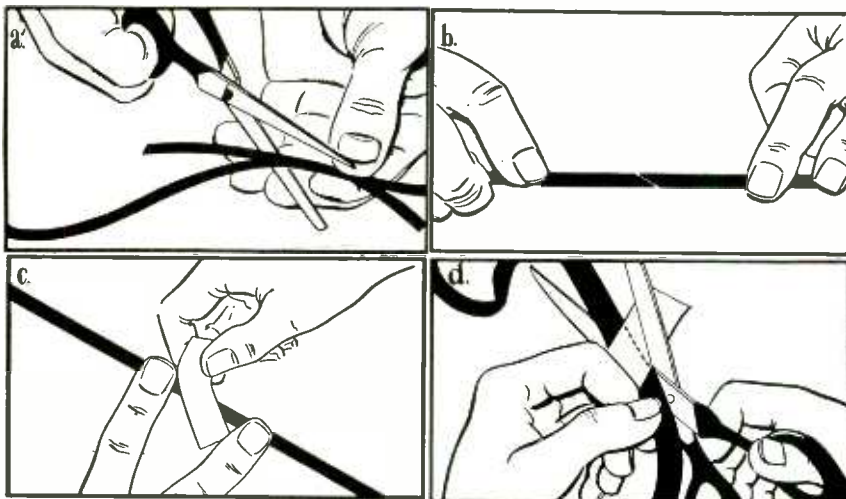

Fig. 4—Correct tape-splicing procedure. Ends are cut at 60-degree angle with unmagnetized scissors, butted as shown, and spliced with cellophane adhesive tape. Commercial splicing jigs are available for high-speed quantity output.

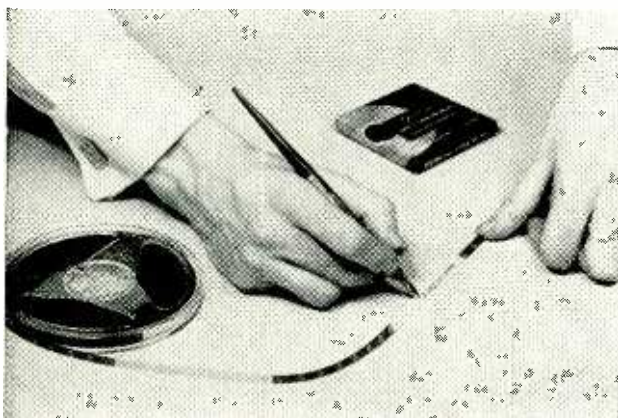
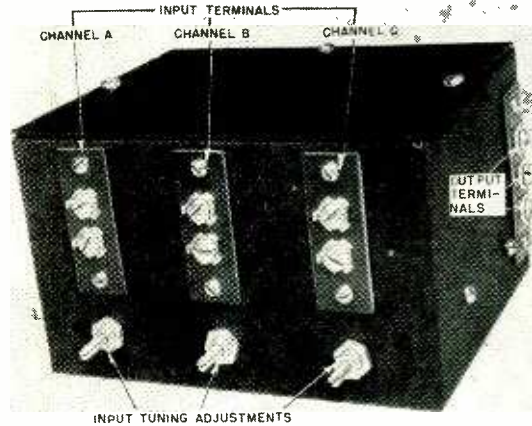

Fig. 5—Leader tape protects recordings, has alternate colored 3 1/2-inch sections for timing program intervals and tape labeling.

Get rid of haywire
and awkward input switching
with this

TV ANTENNA COUPLER

By EDWIN T. BOHR



Coupler antenna terminals and input-tuning adjustments.

THIS coupler does away with TV-antenna switching, provides high-gain boosting, and couples as many as three TV signals into a single transmission line. It can easily simplify many complicated antenna systems.

For example, in an average TV location where a booster is needed, reception is usually possible from no more than two or three channels. If the stations are in different directions, or if Yagis are used, the antenna, the booster, and the TV set must be switched when channels are changed. This is not only cumbersome but extremely embarrassing for dealers trying to demonstrate receivers under these conditions. With the channel coupler a salesman or a housewife can change stations by simply flipping the receiver channel selector. The channel coupler also can be used ahead of distribution units—either the resistor-pad type or vacuum-tube type.

Because the channels are amplified separately, the coupler gives the convenience of an all-band booster with much higher gain. By tying two of the inputs in series, the coupler becomes a pre-set two-channel booster.

The three signal outputs are combined in a common 300-ohm circuit to the receiver.

Coupler circuit

After considerable research and experiment, the familiar cascode circuit of Fig. 1 was adopted. The gain of the first stage is negligible, so there is no danger of oscillation. (Neutralization would give slightly lower noise on the high channels.)

No tuned circuit or choke is used between stages on the low channels. The grounded-grid second stage presents a very low input resistance to the first stage. Since the input capacitance is also low, a resonating coil on the low channels is not necessary and is eliminated to simplify construction. On the high band L5 is used to cancel the interstage capacitance. One value of inductance serves channels 7-13. The

second-stage grid is grounded for r.f. by the .0015- μ f capacitor, and returned to the cathode for d.c. through the 470,000-ohm resistor.

Coil data

The input and output circuits have slug-tuned coils that resonate with the tube and circuit capacitance.

These are wound on $\frac{3}{8}$ -inch diameter slug-tuned coil forms such as the Cambridge Thermionic type LS-3. For channels 2, 3, and 4, the coils are wound with No. 26 enameled wire.

For the other channels, No. 16 enameled wire is used for the grid and plate coils; L1 and L4 are stranded thermoplastic hookup wire wound over L2 and L3. This can be seen in the photographs. The winding data follows:

Channel	TURNS			
	L1	L2	L3	L4
2	3	10	12	3
3	3	9	11	3
4	3	8	10	3
5	3	8	9	3
6	2	7	8	2
7	1 1/2	3	3 1/2	1
8	1 1/2	3	3 1/2	1
9	1 1/2	3	3 1/2	1
10	1 1/2	2 1/2	3	1

Use the channel 10 data for channels 11, 12, and 13, spacing the turns slightly for the correct tuning range. L5 is 8 turns of No. 16 enameled wire, $\frac{1}{4}$ inch in diameter, self-supporting.

For channels 2, 3, and 4 the output coil (L4) should be insulated from the plate winding (L3) by a piece of Scotch electrical tape, since the enamel insulation breaks down easily at 200 volts.

Wind L1 and L4 on top of L2 and L3 at the ground ends of these coils (away from the grid or plate ends). Tight coupling at the ground end of the coil gives the lowest susceptibility to noise

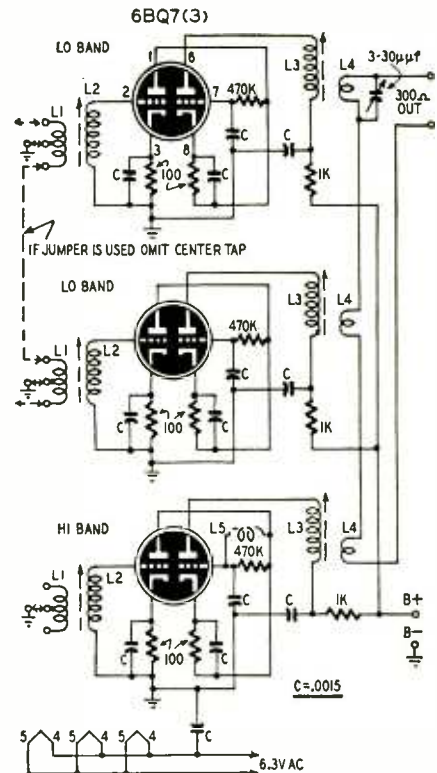

Fig. 1—Circuit of the three-channel coupler-booster. The jumper between the low-band input coils is for use with a common dual-channel antenna.

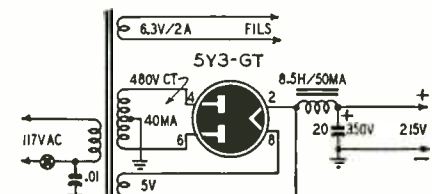
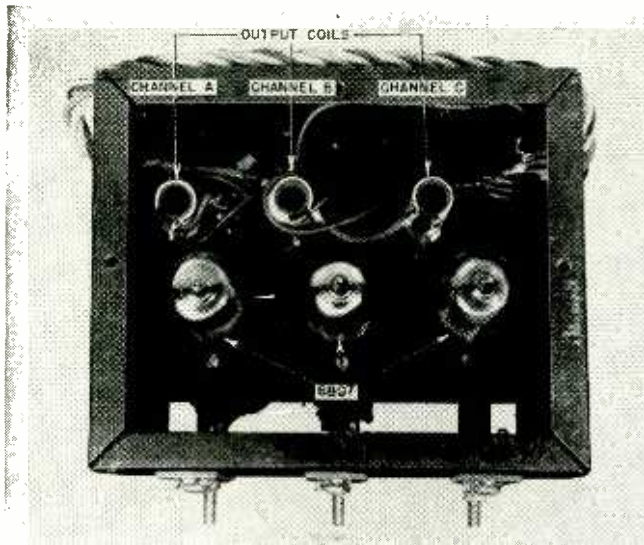

Fig. 2—Schematic of the power supply.

and interference picked up by the transmission line.

Each antenna coil (L1) should be center-tapped.



The completed coupler with top and bottom covers removed.

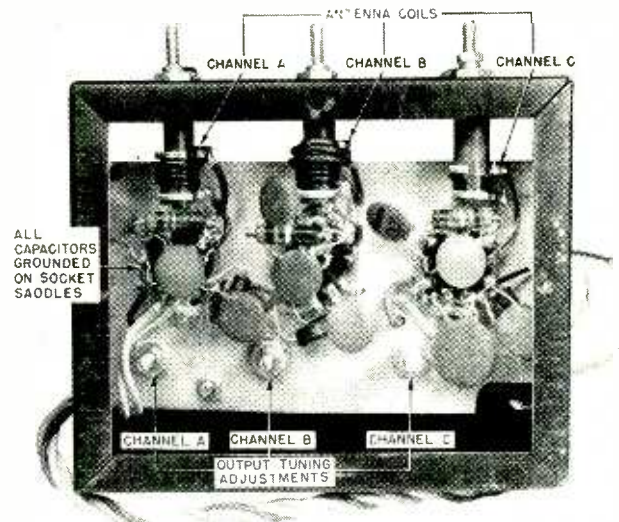

Components and wiring under the chassis.

To obtain maximum tuning range the coils should be wound on the end as far away from the slug as possible. This gives the greatest change in permeability when the slug is screwed into the coil.

The total tube and wiring capacitance across the coil is only about 4 μf . Additional capacitance—even 1 μf —can change the tuning range considerably. Use every precaution in winding and installing the coils to keep stray capacitance at a minimum.

Construction

The layout of the channel coupler is shown in the photographs. All capacitors are grounded directly on the socket saddles. Mounting the input coils on the front of the cabinet gives short, direct leads to the tube sockets. The output coils are mounted on the chassis at right angles to the input coils to minimize inductive coupling. The 3-30- μf trimmer shown in the diagram was not in use when the photographs were taken. It is mounted on top of the chassis behind the lowest-frequency-channel output coil, and is adjusted at the time of installation through a hole drilled in the back of the cabinet.

The metal box is just high enough to accommodate the tubes and the components below the chassis. Mount the chassis so the exhaust tips of the tubes clear the top by about $\frac{1}{8}$ inch. The compactness of the coupler may not be apparent from the pictures. It will nest easily in one hand.

Where continuous operation is expected, four $\frac{3}{4}$ -inch holes should be punched in the removable top and bottom plates. With this type of enclosure the top and bottom of the coupler are easily accessible.

The chassis and cabinet, of course, do not have to be exactly like the ones used in this model, as long as the layout and wiring are kept compact and follow the same arrangement.

A separate power supply (Fig. 2) is used with the coupler. A 40-ma re-

placement type transformer is suitable for continuous operation since each 6BQ7 requires only 10 ma plate current and 0.45 amp heater current. The choke-input filter reduces transformer heating. These components cost less than a comparable selenium-rectifier power supply and provide desirable isolation from the power line.

Installation and tuning

If the channel coupler works best with any of the tuning slugs screwed completely in or completely out, the full channel may not be within the tuning range of the coil. If the gain is maximum with the slug all the way out, reduce the inductance by spreading the turns of wire or by removing a small portion of the coil. If the gain is greatest with the slug completely inside the coil, inductance should be added by squeezing the turns together or by adding a turn (on the low band only). With the correct inductance there is a broad but very definite peak as the slug is turned in or out. The final step is to tune the antenna and plate coil slugs for maximum signal on each channel.

When two inputs are tied together for use with a common antenna, as shown in Fig. 1, the center-taps of the connected coils *should not* be grounded. To simplify this change-over, the input terminals shown in the photographs should be replaced with three-terminal strips, and a grounding screw should be mounted on the case as close as possible to each center terminal. A short link between the center terminal and ground can be added or removed as required.

Output coupling

The output windings of the three individual booster circuits are simply connected in series. Each coil offers an appreciable impedance only over the frequency band to which the plate winding is tuned.

Suppose the coupler is used to com-

bine channels 2, 5, and 8. Here is what happens: The signal from the channel 2 booster is fed to the line in series with the channel 5 and channel 8 coils. These two coils (5 and 8) offer negligible impedance to the lower-frequency signal. The high reactance of the channel-2 coil on the higher frequencies is tuned out with the 3-30 μf ceramic trimmer capacitor. This adjustment is not critical. It can be peaked on channel 2, since it is needed only to balance the inductance of the coil.

Applications

The channel coupler can simplify many knotty antenna systems. With one of these units you will wonder how you ever put up with a conglomeration of wires, boosters, and switches. A TV-set salesman will no longer need to blush and flip five switches to change a channel.

The channel coupler can obviously be built with only two sections; or a single section may be built for use as a simple booster. Its versatility is unlimited.

(In some applications it may be possible to improve the impedance match between the booster output and the receiver input by inserting suitable resistors in each output lead. Various values can be tried until the best overall performance is obtained, or until a particular channel is brought in with the proper relationship between sound and picture.—*Editor*)

Materials for channel coupler

Resistors: 6—100 ohms, 3—1,000 ohms, 3—470,000 ohms, $\frac{1}{2}$ watt.

Capacitors: (ceramic) 13—.0015 μf , 1—3-30 μf trimmer.

Miscellaneous: 3—6BQ7 tubes, 3—9-pin miniature tube sockets, 6—slug-tuned coil forms (Cambridge Thermionic Type LS-3 or equivalent), terminals, connectors, chassis, cabinet, wire, solder, hardware.

Materials for power supply

Miscellaneous: 1 power transformer, 480 volts c.t., 40 ma, 5 volts, 2 amp, 6.3 volts, 1.5 amp; 1 filter choke, 8.5 henries, 50 ma; 1—5Y3-GT; 1—20- μf , 350-volt electrolytic capacitor; 1—.01- μf , 600-volt paper capacitor; 1—s.p.s.f. toggle switch; 1 octal socket; chassis; terminals; wire; solder; hardware.

—end—

BANDSWITCHING REGENERATIVE RECEIVER

A handy, compact unit for signal monitoring, dial-twirling, or emergency standby service.

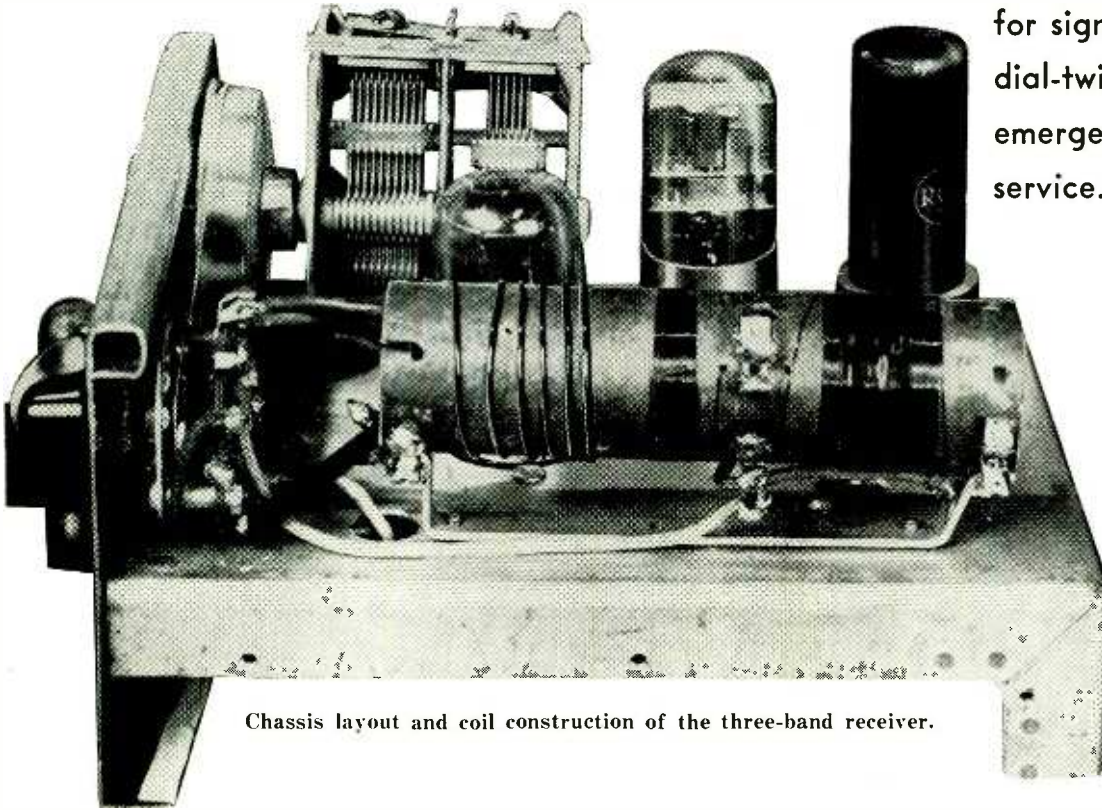

Chassis layout and coil construction of the three-band receiver.

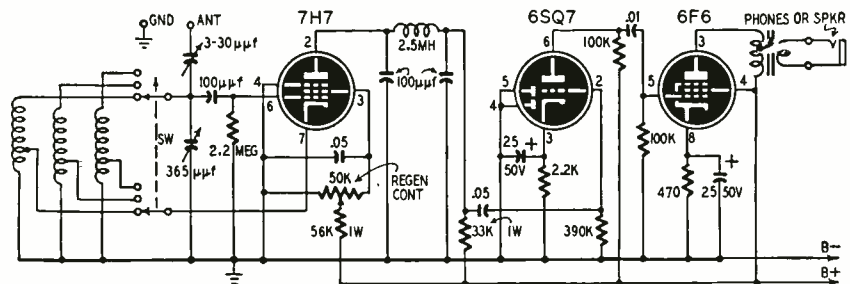

The receiver schematic. Power supply requirements are 6.3 v (a.c. or d.c.) at 1.3 amp; 180-250 v.d.c. at approximately 50 ma. Any single-wire antenna will do.

By C. TIERNEY

THE three-tube receiver pictured here has the advantage of band-switching and can be built with a minimum of parts. The 7H7 loktal detector gives high gain with low losses.

The chassis is 7½ inches deep, 6 inches long, and 1½ inches high. The coil has three windings, one for the broadcast band, one for frequencies between 1500 kc and 4 mc, and one for frequencies between 6 and a little below 16 mc. The coil form is 4½ inches long and 1¼ inches in diameter, with soldering lugs attached in favorable positions for coil lead terminations.

Turns for the bands are: Broadcast, 85 turns, tapped 6 from ground; 160-75 meters, 25 turns, tapped 3½ from ground; 20-meter band, 6 turns, tapped 2 from ground.

The 20-meter winding is spaced over an inch, and is wound with No. 24 enameled wire. The other two coils are close-wound with No. 30 enameled wire. The photo shows position and spacing of all windings. If the detector refuses to oscillate, move the tap a turn or two up the coil.

Put the 20-meter winding nearest the switch, where it will have the shortest leads, put the 160-75 meter winding in the center of the form, and the broadcast coil farthest from the panel. Make all leads from the coil to the switch as short as possible, bringing most of them through the coil form. Except for the leads from the tube's grid and cathode, all coil wiring is above the chassis.

A dial for this receiver can be calibrated by beating the receiver with a calibrated all-wave set. With the two

receivers operating beside each other, and the regeneration control up on this set, a loud whistle will be heard from the all-wave set's speaker when the two sets are tuned to the same frequency. If the calibrated set is a super het, be sure not to zero beat on the image frequency.

Materials for Receiver

Resistors: 1—33,000, 1—56,000, 1—470 ohms, 1 watt; 1—2,200, 2—100,000, 1—390,000 ohms, 1—2.2 meg-ohms, ½ watt; 1—50,000-ohm potentiometer.

Capacitors: 1—365 µmf, variable; 1—3-30 µmf, mica trimmer; 3—100 µmf, mica; 1—.01, 2—.05 µf, paper; 2—25 µf, 50-volt electrolytic.

Miscellaneous: 1—2-pole, 3-position rotary switch; 1—output transformer, 6F6 to voice coil; 1—open circuit jack; 1—7H7, 1—6SQ7, 1—6F6 tubes, 1—2.5-millihenry radio-frequency choke; coil form; No. 24 enameled wire; No. 30 enameled wire; chassis; dial; control knobs; hookup wire; solder; terminals; hardware; sockets.

—end—

ELECTRONIC MULTIMETERS

Electronic multimeters are rapidly replacing the volt-ohm-milliammeter which was formerly the most widely used instrument in service shops, electronic laboratories, schools, and ham shacks. The most common type of v.t.v.m. or electronic multimeter uses two triodes in a bridge circuit with the meter arranged to read the difference in cathode currents. A typical circuit of this type (Fig. 1) is reprinted from *La Radio Revue* (Antwerp, Belgium).

Constructed around a 400- μ a, 500-ohm meter, the instrument measures a.c. and positive or negative d.c. volts in full-scale ranges of 3, 10, 30, 100,

300, 1,000, and 3,000; and resistances from 0.5 ohms to 500 megohms in four ranges.

Fig. 2 shows how the 4 $\frac{3}{4}$ -inch rectangular meter is calibrated. Three scales are used for voltage measurements and one for resistance. The lower voltage scale has a center zero for discriminator alignment and is not directly calibrated. Your local photostatter or photographer can enlarge or reduce the scale to fit your meter.

The RANGE and FUNCTION SELECTOR switches and the OHMS ADJ and ZERO controls are on the front panel. The CALIBRATE and AC BALANCE controls are

mounted on the chassis since they are used only during initial calibration.

The ZERO control sets the pointer to the extreme left of each range for voltage and resistance measurements and to the center zero for discriminator alignment. Adjust the AC BALANCE control so the zero does not shift when switching from a.c. to d.c. volts. If the balance point cannot be found, try different values for R1. The CALIBRATE control is used to set the pointer exactly on 3 volts with a fresh 3-volt battery connected to the d.c. input terminals and the meter set on the 3-volt range. Set the OHMS ADJ control so the pointer is on the last (infinity) division of the resistance scale before connecting the resistance to be measured.

—end—

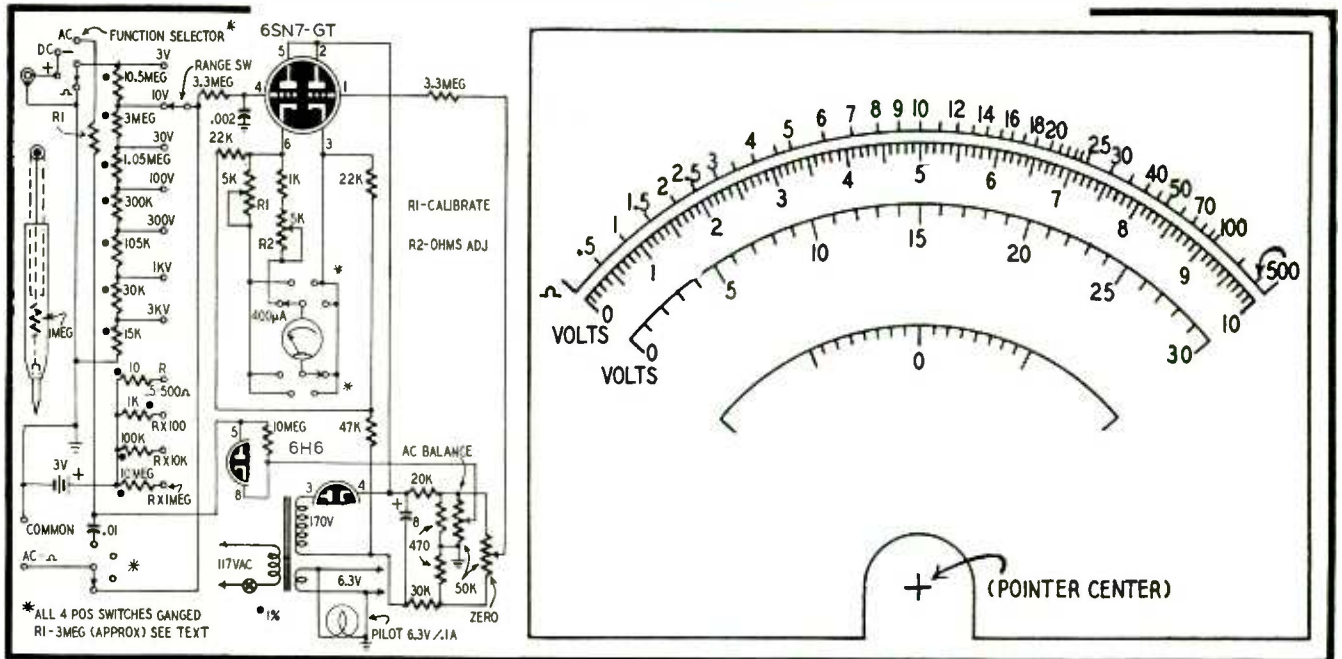

SUPERSENSITIVE PILOT RELAY

The novel electronic pilot relay shown in the diagram is designed around the new TT-1 cold-cathode control tube manufactured by Haledy Electronics Co., of 57 William St., New York, N. Y. Requiring only 2 μ a through the control contacts, the unit is adaptable for machinery control, automatic counting, meter relays, liquid flow meters, strain gauges, and other applications where the external contacts would be damaged by normal control currents.

The TT-1 differs from the 0A4-G in several respects. It has a sprayed-on external electrode which connects to a high-resistance voltage divider between plate and cathode. It is many times more sensitive than the 0A4-G and its starter anode must be *negative* with respect to the cathode to initiate the glow discharge which causes current to flow in the plate circuit.

The starter anode is the control ele-

ment. It is biased highly negative by the charge placed on C1 by the rectifier. The starter anode must be at least 20 volts negative with respect to the cathode to initiate the glow discharge. If the control contacts are shorted or connected through a resistance of less than 10 megohms, the starter-cathode potential will not be high enough to produce a glow discharge.

The voltage across the capacitor, about 120 volts, appears across a voltage divider consisting of R1, the resistance across the control contacts, R2, and R3. Since the starter connects to the cathode through R1, R2, and the resistance across the contacts, the total resistance in the starter-cathode circuit must be high enough to raise the starter-cathode voltage to the discharge point.

The minimum resistance required for firing the tube can be raised or lowered

by varying the values of R2 and R3.—*Edward Spierer and Harry Peach.*

(Experimenters may use a 1C21 or 0A4-G in this circuit if they use a sprayed-on graphite layer as the external electrode as described in the article, "Increase Sensitivity of Cold-Cathode Tube" on page 102 of the February, 1951, issue.—*Editor*)

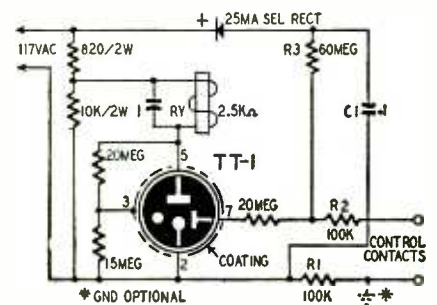

FREQUENCY STABILIZED DIATHERMY

THOUSANDS of diathermy machines were rendered obsolete by the Federal Communications Committee's ruling, July 1, which made frequency stabilization mandatory. A great deal of enthusiastic effort has been directed to converting existing sets to crystal control. These endeavors invariably resulted in technical frustration and financial disappointment.

The typical diathermy apparatus generates several hundred watts of high-frequency energy with a pair of medium- or low- μ triodes connected as a self-excited oscillator and powered by raw a.c. At first glance, it would appear to be possible to convert the oscillator circuit to a neutralized class C amplifier driven by a crystal-controlled exciter. Actually, this method is impractical in most instances. The triodes are difficult to neutralize because of the wide range of load conditions and require considerable grid power from the exciter. Since r.f.-bypass and tank circuit-resonating capacitors are absent in the majority of sets, redesign of the tuned circuits is necessary. Usually the cabinet will not accommodate such components, not to mention a bulky exciter unit and power-supply apparatus. (The same FCC stipulation makes filtered d.c. a requisite.) As a consequence, "conversion" actually means complete rebuilding of the equipment, including construction of a new cabinet.

The author experimented with cathode-follower amplifiers, grounded-grid circuits, and synchronized oscillators. These gave satisfactory performance when judged against amateur transmitter requirements. However, no arrangement could be passed as foolproof for service in the workaday world of medical therapy, which does not include supervision by an electronic technician. Clearly, a new and unique approach is indicated, one which will put in the physician's hands a reliable diathermy machine reduced to the lowest terms of engineering simplicity, and without compromise of performance.

Use a tetrode

Fortunately, there is an excellent solution to the problem. The Eitel McCullough Co. (and others) make a series of r.f. power tetrodes which deliver up to 500 watts output when driven by a small exciter made from receiving-type tubes and parts. Neutralization is either unnecessary, or extremely easy. Only one such tetrode is required. These tetrodes are physically small compared to the triodes in existing diathermy sets and are better suited for high-frequency operation. They are usually less expensive than the pair of old-fashioned triodes which would be



A tested design that meets stringent FCC requirements for interference-free operation.

By IRVING GOTTLIEB

needed to furnish a comparable power output.

The three tubes best suited for application in crystal-control diathermy are the 4-250A/5D22, the 4-125A/4D21, and the 4-65A with plate dissipation ratings of 250 watts, 125 watts, and 65 watts respectively. The set described uses the 4-250A and can deliver power in the vicinity of 500 watts. This power capability is greater than that of the average self-excited diathermy equipment; accordingly, if a smaller output is suitable, one of the smaller tetrodes may

be used, with a saving in tube and power-supply expenditure. The 4-125 will furnish output power comparable to most of the older diathermy sets, and the 4-65A will generate enough power to be useful for many therapeutic applications. The basic design is the same for any of the three tubes, it being necessary only to provide the appropriate filament and plate supplies.

A tested model

The photographs show a 500-watt set built and tested in the engineering lab-

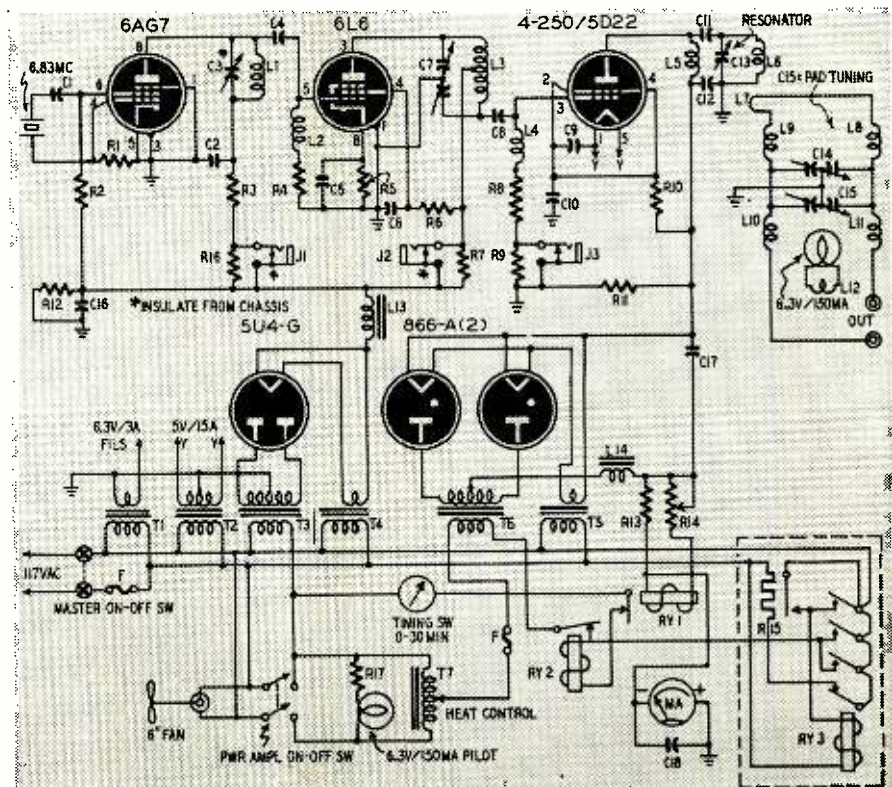

Schematic of the crystal-controlled, 500-watt diathermy set developed by Eimac.

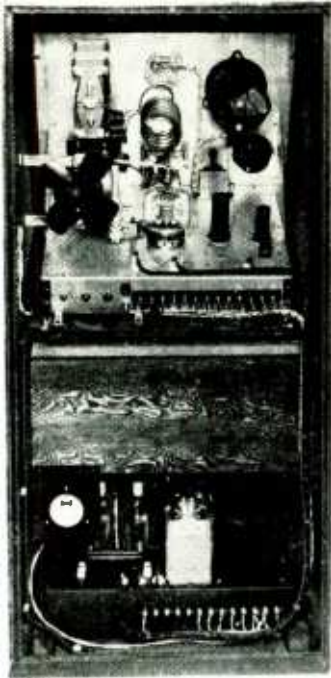

Rear view of the installed diathermy machine, showing how the separate r.f. and power-supply chassis are mounted.

oratory of the Eitel McCullough plant. The power output is made continuously variable with a primary-circuit Variac. No neutralization is required for the output frequency of 27.32 mc. This is the most popular of the short-wave frequencies allotted for diathermy purposes. Once tuned for resonance, the plate tank capacitor need not be further adjusted for any load conditions. Either of the other two frequencies 13.66 or 40.98 mc, can be used by making appropriate changes in the exciter and output tank circuits. The highest frequency can be attained by tripling in the oscillator and doubling in the driver stage. There is still sufficient drive to excite the power-output stage to full output.

The circuit (see the schematic diagram) is straightforward and involves no trick circuits. In addition to good layout and wiring practices, it is necessary to provide about 5 cubic feet of air per minute to cool the base of the 4-250A. A 6-inch fan produces the required convection and cools the power-supply components as well. Good high-frequency practice calls for several special considerations when dealing with r.f. power tetrodes. High-frequency components which precede the tetrode should be located beneath the chassis, and the filament and screen bypass capacitors in the tetrode stage must be grounded as directly as possible.

The exciter consists of a 6AG7, connected as a combined Pierce oscillator and frequency multiplier, and a 6L6 frequency multiplier driver. With a 6.83-mc crystal, the 6AG7 output tank circuit is tuned to the second harmonic, 13.66 mc. This is again doubled to 27.32 mc by the 6L6 stage, enabling the 4-

250A tetrode to operate as a straight class C amplifier. The 6L6 should be the metal-envelope type to prevent capacitive coupling to the plate circuit of the tetrode output stage. The same applies to the 6AG7 tube. The r.f. choke in the plate circuit of the tetrode output stage must not have excessive distributed capacitance and must not be mounted closer than two-and-a-half diameters to metallic objects. Observance of these points results in a smooth-operating class C output stage which requires no neutralization over the entire range of load conditions.

Several of the circuit features are due to the special demands of the practice and technique of diathermy. A load coupling network consisting of L7, L8, L9, L10, and L11 and capacitors C14 and C15 permits tuning for efficient power transfer under widely varying load resistance and reactance conditions. Only C15 is adjustable from panel; C14 is initially adjusted to give proper tuning range of C15. A small pilot lamp is inductively coupled (by L12) to the outgoing leads and provides visual guidance in resonating the

patient. A 0-500-ma meter in the tetrode plate circuit indicates the degree of loading, which is controllable by a Variac in the primary of the high-voltage supply. Operating instructions should clearly explain the proper sequence of adjustment: the patient is "tuned in" by varying C15, with the power-control Variac set at a low level. Then the Variac is advanced to a higher power level. The experienced therapist or physician can readily correlate the plate-meter reading, the patient's reaction, and his own experience with diathermy techniques, to give a specific therapeutic treatment. A timing switch automatically regulates treatment duration from one to thirty minutes when desired.

Included also are an overload relay (RY-1) and a time-delay relay (RY-3). The overload-relay reset button is mounted on the control panel so that operation is easily restored following an interruption, such as might be caused by bringing the treatment pads too close to one another. The time-delay relay should allow the filaments of the high-voltage rectifiers about three min-

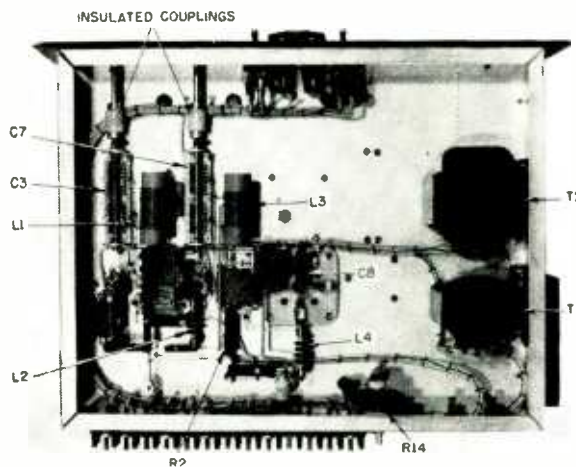

Under the r.f. chassis, T1 and T2 cut power losses by keeping high-current filament leads short. Note professional-looking layout and wiring.

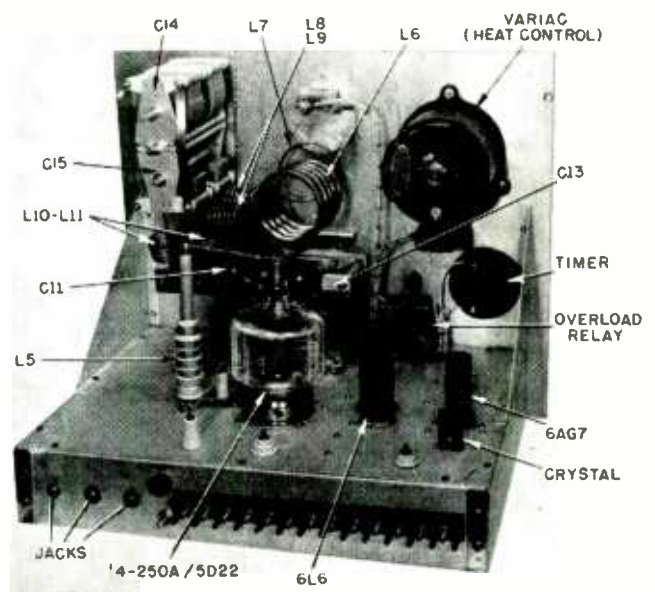

The r.f. unit and control panel. All parts are standard commercial types. Forced-air cooling prolongs tube life.

utes heating time before application of the plate potential. The pads and output cords should be obtained from one of the reputable manufacturers of therapeutic apparatus, such as the H. Fischer Co., of Chicago.

Anyone with experience in constructing and operating medium and high power transmitters should be able to build diathermy sets. The design and performance of this diathermy will merit FCC approval. Here then, is an excellent opportunity for the enterprising would-be-manufacturer who has been seeking a way to capitalize on his knowledge, for the diathermy machine market is now wide open.

References:

Bulletin No. 1: Eitel-McCulloch Inc.
Crystal-Controlled Diathermy; R. L. Norton.
Electronics, October, 1946.

PARTS LIST

Capacitors

- C1—.002, mica.
- C2—.002, mica, 600 volts.
- C3—60 μ f, variable capacitor.
- C4—.001, mica, 600 volts.
- C5—.004, mica.
- C6—.004, mica, 600 volts.
- C7—split-stator variable capacitor, 30 μ f per section.
- C8—.001, mica, 600 volts.
- C8—.0001, mica, 600 volts.
- C9—.032, mica, 5,000 volts.
- C10—.002, mica, 5,000 volts.
- C11—.002, mica, 5,000 volts.
- C12—.002, mica, 5,000 volts.
- C13—50 μ f, transmitting-type tuning capacitor (0.1 inch minimum plate spacing).
- C14—split-stator variable capacitor, 100 μ f per section (0.1 inch minimum plate spacing).
- C15—Same as C14.
- C16—2 μ f, 600 volts, oil-impregnated paper.
- C17—2 μ f, 3,000 volts, oil-impregnated paper.
- C18—.01 mica.

Resistors

- R1—51,000 ohms, 2 watts, carbon.
- R2—30,000 ohms, 10 watts, wire-wound.
- R3—8,000 ohms, 10 watts, wire-wound.
- R4—100,000 ohms, 2 watts, carbon.
- R5—500 ohms, 10 watts, wire-wound.
- R6—30,000 ohms, 10 watts, wire-wound.
- R7—100 ohms, 2 watts, carbon.
- R8—10,000 ohms, 10 watts, noninductive wire-wound.
- R9—100 ohms, 2 watts, carbon.
- R10—25,000 ohms, 100 watts, wire-wound.
- R11—Two 100,000-ohm, 50-watt, wire-wound resistors in series.
- R12—50,000 ohms, 25 watts, wire-wound.
- R13—100 ohms, 10 watts, wire-wound.
- R14—100 ohms, 25 watts, adjustable, wire-wound.
- R15—Heater in time-delay relay.
- R16—100 ohms, 2 watts, carbon.
- R17—750 ohms, 10 watts, wire-wound.

Miscellaneous

- T1—Filament transformer—6.3 volts, 3 amps.
- T2—Filament transformer—5 volts, 15 amp.
- T3—Power transformer—1,050 volts, center-tapped, 150 ma.
- T4—Filament transformer—5 volts, 3 amps.
- T5—Filament transformer—2.5 volts, 10 amp.
- T6—Power transformer 6,000 volts, center-tapped, 150 ma.
- T7—Variac—800 volt-amperes.
- Ma—0-500 d.c. milliammeter.
- Timer—Rotary timing switch such as manufactured by the Haydon Mfg. Co. Timing duration 1 to 30 minutes.
- Time-delay relay—Can be either thermal or clock motor type. Should allow 3 minutes of heating time for rectifiers before application of high voltage.
- RY-1—Overload relay. D.c. relay with solenoid requiring 0.1 to 0.3 amp. Current actually circulating through winding is adjustable by R14. Contact points must be capable of handling about 1 ampere inductive load.
- RY-2—High-voltage relay, 120-volt, a.c. solenoid. Points must be capable of handling 10 amp inductive load.
- L13—10-henry filter choke, 100 ma.
- L14—12-henry filter choke, 300 ma.

Coil Table

- L1—12 turns No. 16 enameled solid wire spaced for winding length of $1\frac{1}{4}$ inch on $1\frac{1}{8}$ -inch form.
- L2—2.5-mh r.f. choke, 125 ma.
- L3—9 turns No. 16 enameled solid wire spaced for winding length of 1 inch on $1\frac{1}{8}$ -inch form. Tap at fifth turn down from plate end of coil.
- L4—2.5-mh r.f. choke, 125 ma.
- L5—225- μ h r.f. choke, 800 ma (National Co.'s R-175).

- L6—5 turns $\frac{1}{8}$ -inch copper tubing spaced to occupy length of $2\frac{1}{2}$ inches. Inner diameter of coil is 2 inches.
- L7—One-turn coupling coil, $\frac{1}{8}$ inch copper tubing. Inner diameter of coil is 2 inches. Space about $1\frac{1}{4}$ inch from L6.
- L8 & L9—5 $\frac{1}{2}$ turns $\frac{1}{8}$ -inch copper tubing spaced to occupy winding length of $1\frac{1}{2}$ inch. Inner diameter of coil is $1\frac{1}{8}$ inch.

- L10 & L11—5 Turns of $\frac{1}{8}$ -inch copper tubing spaced to occupy winding length of $1\frac{1}{4}$ inch. Inner diameter of coil is $1\frac{1}{8}$ inch.
- L12—Hairpin pickup loop for resonating lamp. Form of No. 16 solid wire about 2 inches long. Space between leads connecting L7 and L8 to their respective output jacks. Actual spacing must be determined by experiment.

—end—

"WRISTWATCH" RADIO COMES TO LIFE

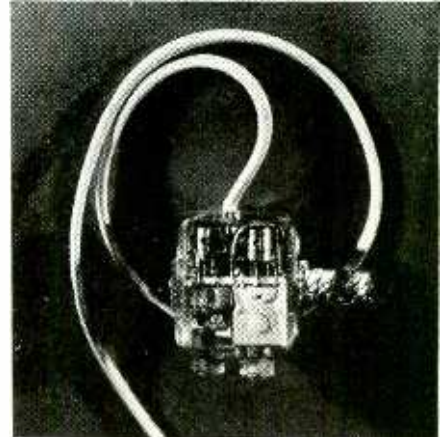

"Dick Tracy" wristwatch radio is smaller than a pack of cigarettes, uses transistors instead of tubes. Built in their spare time by two Western Electric engineers as a gift for Chester Gould, creator of the comic-strip detective, the $1\frac{1}{2} \times 2 \times \frac{3}{4}$ -inch receiver has an r.f. amplifier, regenerative detector, two transformer-coupled a.f. stages. Only components not in the wristfitting

plastic case are the 1-inch lapel speaker, hearing-aid type B battery, and antenna wire (worn under the coat). Tiny knobs control tuning and volume.

This little wristwatch radio is, of course, an experiment, and is not likely to be manufactured in the near future. It is important because it shows what transistors may be able to do at a not-too-distant day.

BRASSPOUNDING BUG BITES BEAUTY



A velvet "fist" on the 80-meter band. One of the youngest and prettiest newcomers to ham radio, 12-year-old Carole Millett of St. Cloud, Minnesota, signs WØIKJ on 3744 kc, doesn't let brass pounding interfere with music and stamp collecting. Carole was trained by dad Beryl Millett, WØRIL.

Modern electronic communications inspire

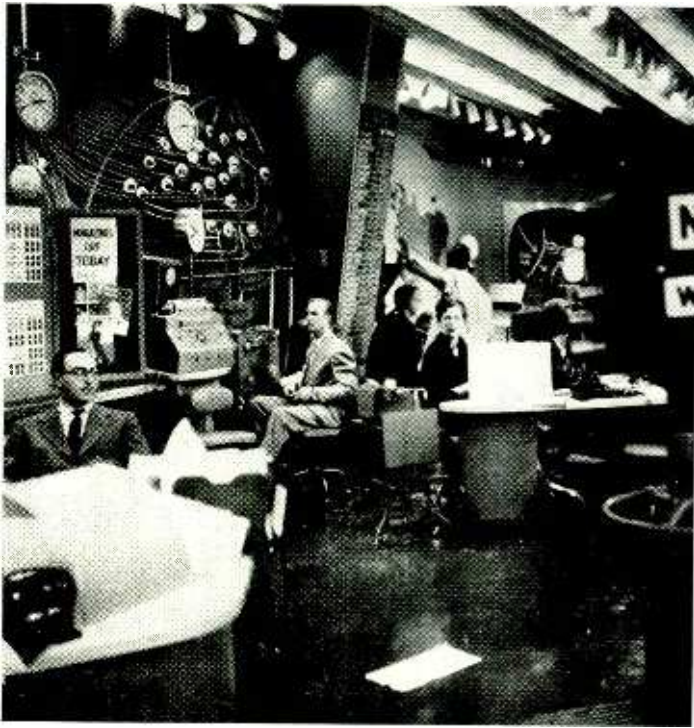

"Today's" communications center. Clocks show time at overseas news points.

UNIQUE METHODS IN A TV NEWS PROGRAM

By ERIC LESLIE

THE NBC TV news program "Today" calls the scene of its broadcasts a communications center, not a studio. Tape recorders, teletypes, and facsimile (wirephoto) machines are as important to the program as Garroway himself. No small part of the program comes from the outside while the show is actually in progress. While news from the United States is being received on one teletype machine, European news may be coming in from Reuters on another. Two tape recorders pick up voice broadcasts from other cities and hold them for insertion in the program at the proper times. Important items may be rebroadcast immediately. TV pickups from outside points, either live or kinescope, may form part of the programs. And the ordinary Bell telephone plays an important part in getting the news.

All these devices, plus the unusually early program time, have helped "Today" put across an occasional news beat, and keep a little ahead of other TV programs on at least part of the news.

When you hear the program depends on where you live. For Garroway and his staff it runs from 7 to 10 a.m. Viewers in the Eastern Time Zone see the first two hours. Those on Central Standard Time hear the last two hours, though for both groups the program runs from 7 to 9 on the clock.

The "communications center" itself is as unconventional as the broadcast time. The show takes place in a large area of the RCA Exhibition Hall in New York City, in full view of the passers-by—who may sometimes find themselves on the program when a

cameraman occasionally turns his instrument on them.

An ordinary day on the air starts with Garroway reading the newspaper headlines while the camera—and the viewers—also scan them. Then outside reporters may come in—occasionally by TV from other American cities, sometimes by voice only from overseas. A brief commercial and quickie weather report may follow. Then the TV camera scans the teletype strip, reading the news that has just been summarized orally. While this is going on, the audio end is kept busy with recorded music—often the first playing of a new hit tune.

The main weather forecast is an important part of "Today's" program. A little after 10 minutes past the hour, Garroway phones the Weather Bureau in Washington, and listens (with the TV audience) to the full daily forecast, marking up a large weather map with the data received by phone.

Besides the official weather broadcast, shorter ones dot the hour, with readings of the long weather board seen at right center of the photo, which shows the temperatures of all large United States cities. Another large board carries baseball scores, and a third is used for newspaper clips. A special device, called a Vu-graph, consists of a screen on which sketches, graphs or maps may be drawn and televised. Extensive changes, additions, or notes to the main drawing can be made on transparent plastic overlays before or during the program and dropped into place instantly.

Telev viewers hear the news at least four times during each hour's broadcast. Between newscasts there may be movie

shorts (at one time the viewer was taken on a tour of United States cities, at the rate of one per day), more new records, and the day's special feature, which may be anything up to an interview with a trio of shapely girl life-guardians in bathing suits.

While Garroway and one or two others do practically all the work before the camera, there may be as many as a dozen people on the set during the broadcast. Two girl secretaries are continuously busy receiving news reports, checking with outside sources, posting latest news and temperatures on the boards, and otherwise keeping the program up to the minute. Technicians and operators man the teletypes, tape recorders, and facsimile equipment. Cameramen, directors, and others not directly on the set bring the number of active participants to over 30. And when engineers, writers, advertising salesmen, and all other full-time workers on the program are counted in, the number runs up to 105.

At five minutes before the half hour and the hour, any one of the 38 network stations handling the show may cut in with five minutes of local news or other features. Meanwhile the program goes on at those stations which do not take advantage of the 5-minute breaks.

The one-hour show is repeated three times, with late news items added and with variations and new records for those who may sit through a second viewing. At 10, Eastern Time, the cast and crew can relax for breakfast, presumably glowing with satisfaction at being participants in one of TV's most original and most valuable programs.

—end—

A down-to-earth discussion
of mobile interference with lots
of practical remedies

By **CAPTAIN WILLIAM H. MINOR, USAF**

THE radio service technician or radio operator who has just installed communications equipment in a mobile unit may find he has a number of headaches ahead of him in the form of electrical interference. He must usually work out his difficulties

himself. There is little reference material available on the subject of mobile radio interference, and the average auto mechanic is neither interested in nor trained for many of the electrical problems the radio man or communications engineer may bring him. (His

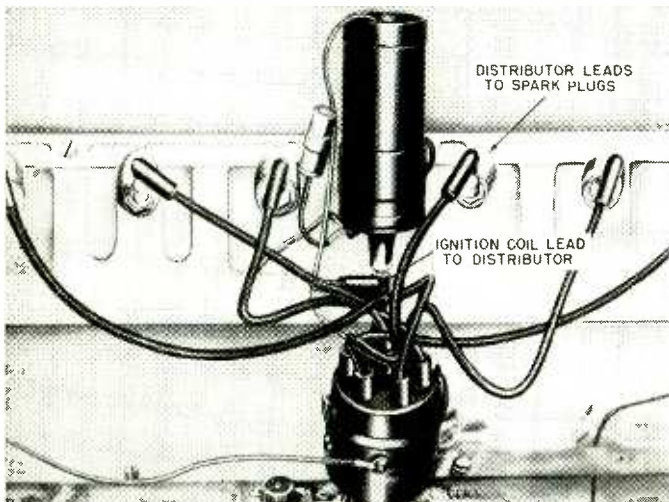

The distributor, coil, and spark plugs cause an easily recognized type of interference. Shielding and suppressors minimize the noise.

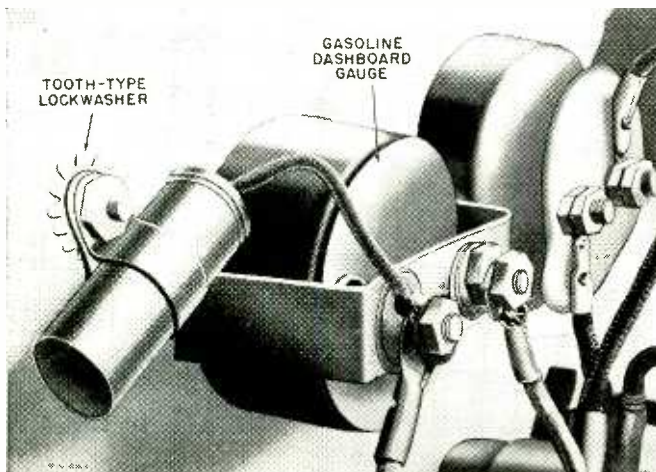

Electrically operated gauges are often a source of interference. Bypass hot lead with capacitor grounded as shown in photo.

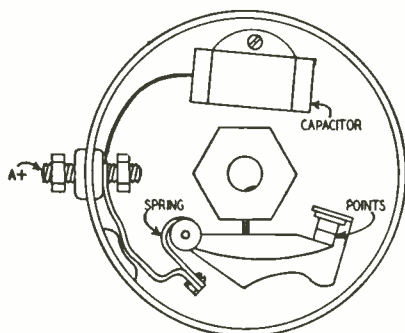

Fig. 1—The distributor breaker box. Opening and closing of points causes transient oscillations which generate noise over a wide range of frequencies.

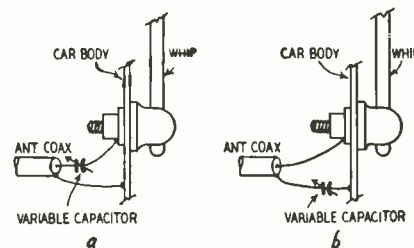

Fig. 2—(a) Impedance-matching circuit in a mobile antenna installation. The capacitor should be completely shielded to reduce pickup of ignition or other noises. (b) Another method of impedance matching used in some cases but not recommended since coax shield is floating.

MOBILE

interest does not go beyond seeing that the electrical system keeps the car running smoothly and the battery properly charged.)

Listening to interference in the receiver is the best way to identify the source. Each type is characterized by a sound all its own. Avoid hasty conclusions, though, for some can be confusing.

Ignition Noises

The most common source of ignition interference is the high-voltage discharge that takes place every time a spark plug fires. Each spark generates a series of damped r.f. waves with very strong harmonics. The interference is not too bad in the broadcast band, but gets worse as the frequency increases. It is most severe at about 30 mc.

Spark interference is easy to recognize. With the engine idling each spark discharge is heard as a "pop" in the receiver. As the engine accelerates, the "pops" blend into a continuous rasping noise that varies with the engine speed.

There are other direct and indirect causes of ignition noises. Dirty plugs, bad ignition cables, pitted points, and poor suppressors would be direct causes. Trouble in the voltage regulator, loose electrical wiring, or a bad distributor capacitor could be indirect causes.

When ignition interference is encountered, remove each plug and inspect the ceramic for even the smallest cracks. Cracked plugs should be replaced without question. Clean the body of the plug with a cloth dampened in gasoline or other solvent. The business end of the plug should be cleaned with a blast of ceramic grit and air and the gap should be reset.

The gap is quite important. Car and plug manufacturers specify the correct gap for each car and plug type, with and without a radio installation. Check with a good mechanic if there is any doubt as to the correct gap. Measure gaps with a round not flat, gauge.

Be careful in pulling and installing spark plugs. Use the right tools to avoid cracking the ceramic. Use good

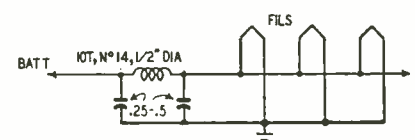

Fig. 3—Heater-line ignition-noise filter of a type employed successfully in most types of commercial automobile radios.

INTERFERENCE

gaskets. Do not tighten the plugs too much or leave them too loose. See that the top terminal nut is tight.

Next check the distributor (Fig. 1). Remove the cap and clean it with gasoline. Inspect it for cracks. This particular part seldom needs replacement, but you should not overlook any possibility. Inspect the distributor points for burning and pitting. (These may be pried apart with a screwdriver. The spring tension is heavy.)

It is good practice to replace distributor points every 10,000 miles, though this is not a hard-and-fast rule. When points are changed it is always good insurance to change capacitors too.

If there is any reason to remove the whole distributor, the firing must be timed when it is replaced. This should be done by a mechanic with adequate facilities.

Inspect the ignition harness. The heavy cable should be covered with good live insulation, free from brittleness and cracks. The metal clips at the ends should be clean and should bite through the insulation into the wire. They should fit the plug terminals firmly. Modern high-compression heads require very high firing voltage. Bad ignition harness can cause corona and leakage discharges which show up as noise in the receiver.

If noise persists after these precautions, some form of suppression may be necessary. For the sake of efficient car operation, this should be held to a minimum. First try a single good carbon suppressor at the center lead into the distributor. If this does not help, put suppressors on the individual plugs. Use good carbon types. Suppressor-type spark plugs are even better.

The indirect causes should be checked. When plugs foul too quickly or points go bad after only a few hundred miles, the trouble may be in either the battery-charging system or the distributor capacitor.

If your battery requires frequent addition of water, check the charging system. A voltage regulator which main-

tains full charging rate on the ammeter even after long trips can cause pitted points. Check and tighten all leads between the regulator, battery, and generator. If the full charging rate still continues, have the battery checked and the voltage regulator adjusted if necessary.

Antenna-system Noise

You may find that after all fault possibilities in the ignition system have been tried and corrected, the noise—or part of it—persists. There are still several ways in which interference can find its way into the radio. These should be individually checked.

The antenna lead-in is one offender. This lead must be fully shielded between the base of the antenna and the receiver. In some installations a braided-wire connection is made from the shield to the car body at the point where the lead connects to the antenna. This ground lead must be short—not over 1/4 inch. The difference between 1/2 and 3/4 inch may mean the difference between bad and good reception. The standard shielded antenna plug at the receiver eliminates pick-up at that end.

Amateur operators who use the same antenna for transmitting and receiving sometimes use a variable capacitor for matching the antenna to the transmitter. Two commonly used methods are shown in Fig. 2-a and 2-b. Both of these can permit interference to creep into the receiver input. The system of Fig. 2-a can be used if the capacitor is mounted in a shielded box. *Method 2-b should not be used.* It is better to use a loading coil in the whip. This may be base, center, or top, but *should not be inside the car in series with the lead-in.*

Other sources

Ignition noises can enter the receiver through the filament circuit. This is particularly true of home-constructed converters and receivers. If this is suspected as a point of entry, add the simple filter shown in Fig. 3. The coil can be about 10 turns of No. 14 wire about 1/2 inch in diameter. The capacitors can be 0.25 or 0.5 μ f. This type filter is common in auto receivers and may be taken from an old unit. Notice, though, that in commercial sets the capacitor is usually a "spark plate."

In some instances it may be found that additional bypass capacitors are necessary. A 0.5- μ f capacitor across the ammeter may eliminate some ignition noise. The temperature indicator has long connecting leads to a thermocouple mounted in the motor lead. A 0.5- μ f capacitor across the thermocouple will sometimes help. The capacitor should be a type which will not be broken by engine vibration. The type used on the generator is quite satisfactory.

As a last resort bonding may help. This will rarely have to be more than a short braided wire connecting the hood to the car body. *Make it short* and install it where it will not interfere with lifting the hood.

Generator Noises

A third source of interference is the generator. This is easy to identify by its characteristic whining noise in the receiver. If the commutator or brushes are bad, a popping noise can accompany the whine. The interference rises in pitch as the engine speed increases.

Remove the band from the generator and inspect the brushes and commutator for wear, dirt, and pitting. Replace pitted and worn brushes.

A dirty commutator can be cleaned by holding a piece of No. 00 sandpaper against it with a small block of wood. Let the engine idle so the generator turns slowly. *Never use emery cloth to clean the commutator.* Use oil when

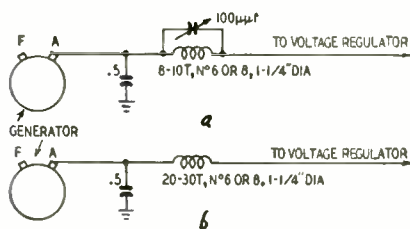

Fig. 4—(a) Tunable generator-noise filter for mobile communications equipment. (b) A simpler form of generator filter, tuned by trimming down the choke coil.

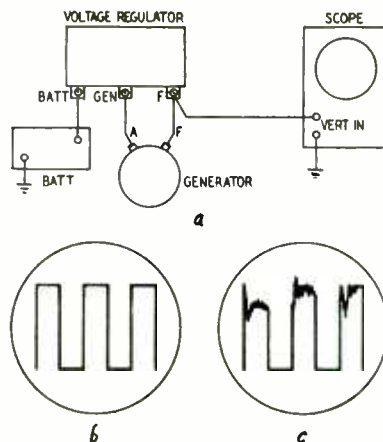

Fig. 5—(a) Hookup for checking voltage-regulator operation with an oscilloscope. (b) Normal voltage-regulator output. (c) Irregularities mean bad contacts.

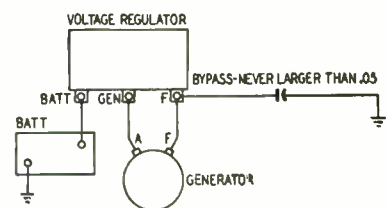

Fig. 6—Bypass capacitor from generator "F" terminal to ground may reduce voltage-regulator hash. Capacitor should be metal-cased and limited to value shown.

necessary but avoid over-oiling, for this can gum up the commutator.

A deeply cut or pitted commutator must be turned down on a lathe. This should be done by an experienced mechanic.

The generator should have a bypass capacitor from the "A" pole to ground. Its value is usually around 0.5 μ f.

The whining noise noticed around 14 or 28 mc may be eliminated entirely by the use of the filter shown in Fig. 4-a or 4-b. In 4-a the coil is 8 or 10 turns of No. 6 or No. 8 wire wound on a short piece of broomstick and shunted with a 100- μ f trimmer. This can be tuned for minimum whine in the receiver while the engine is turning at cruising speed.

Since the filter is not critical, the circuit shown in Fig. 4-b can be used. This coil is 20 to 30 turns of No. 6 or No. 8 wire on a piece of broomstick. Exact specifications cannot be given, for they will vary with installations. Start with 30 turns and remove a turn or two at a time until the whine disappears.

Generator noise can also be caused by wiring or voltage-regulator trouble. First inspect the generator after the car has been run for a short time. If

the generator runs hot, look for loose connections between the generator and voltage regulator. If these are O.K. the regulator should be checked and adjusted.

Voltage-regulator noises

The voltage regulator can be an indirect cause of several types of interference. It can also be a *direct cause*, for there are vibrating relays in the unit. One of these operates when the battery is at or near full charge. During this time it may vibrate as often as 200 times per second. Corroded, burned, or bouncing relay points can cause severe interference.

This source can be identified by an intermittent hissing noise in the receiver. Often the ammeter pointer bounces in step with the noise. A good way of testing for this noise is to connect an oscilloscope as shown in Fig. 5-a. The trace should be a good square-wave (Fig. 5-b). An irregular trace (Fig. 5-c) would indicate bounce or arcing and would be accompanied by interference.

The voltage regulator is a touchy instrument, and the cure may present something of a problem. If the relay contacts are badly burned, the best bet is to replace the regulator. Slightly-pitted contacts can be cleaned with a good point file and wiped with a lintless cloth. The gap and spring tension must be adjusted for correct voltage output (consult the manufacturer of the particular regulator). Also clean the make-and-break.

If interference persists a bypass capacitor can be connected between the generator "F" lead and ground. (Fig. 6). Under no circumstances use more than .05- μ f. A .005- μ f unit will probably be sufficient.

A word of caution. This type of interference can be completely eliminated by misadjusting the voltage-regulator relay. If this is done, the regulator will not operate properly and the battery and distributor points may be ruined. The oscilloscope test would show no square wave output from the regulator. *Avoid this misadjustment.*

Wheel and tire noise

Occasionally noise is introduced through the car wheels. This can be caused by poor bonding between the wheels and axles. A good way to distinguish this from electrical-system interference is to allow the car to coast at high speed with the engine off. If the interference continues, the cause is probably in the wheels.

Practically all wheel noise can be eliminated by installing bonding springs between the wheels and the axles. These are standard items with most parts suppliers.

Certain types of tires cause a singing or whining interference which is most noticeable on the black-top or macadam roads. The same test given above for wheel noise can be made. Driving with two wheels off the paved surface of the road will lessen the noise. A powder is

available at most radio supply houses which can be inserted in the tire tubes. This will eliminate tire noises.

Static-discharge noises

Static discharge occurs when the car is moving or during thunderstorm conditions. It is a steady crackling sound almost identical to ignition noise when caused only by car motion. It can be distinguished from ignition noise because its intensity depends upon *car speed* while ignition noise depends on *engine speed*.

A metal brush with many small sharp points can be attached to the car body. The fine points discharge the static into the air before it can build up to a severe noise level.

An intermittent hissing noise starting at high intensity and diminishing quickly is usually whip discharge. It is most frequently noticed during thunderstorms, but can occur at any time the car is in motion. The static built up in the car may discharge through the sharp tip of the antenna rod. This can be reduced by attaching a metal ball to the antenna tip. The brush mentioned above will also help.

Other noise sources

Any other electrical device insulated from the body of the vehicle may be a source of interference. This applies to panel instruments (ignition switch, ammeter, gasoline gauge, light switches, heater and defroster controls, electric clocks, cigar lighters, etc.), interior lights with door-operated switches, ventilating fans, and especially blinker-type warning signals. Wherever possible the ground side of each device should be bonded to the body of the car, and the hot terminal bypassed with a 0.5- μ f *shielded* capacitor. All mechanical control shafts entering the body through shock- or moisture-proof mountings should be grounded.

Receiver modifications

A noise-clipper circuit may be installed in the receiver to limit extra-strong peaks and reduce interference originating outside the vehicle. A very effective and simple clipper (from the Hammarlund HQ-129X) is shown in Fig. 7. Connections to the receiver will depend on the second detector circuit. Three methods are shown in Fig. 8 (See "Cut QRM With Noise Limiters," by Alvin B. Kaufman, in the June, 1951, RADIO-ELECTRONICS.—*Editor*.) The 6H6 has been found to work slightly better than the 6AL5, but the advantages of each type should be considered in adding the circuit. Make every effort to eliminate locally-generated noise *at the source*. Use the clipper to cut down externally-generated noises. A Greyhound bus, for example, can be heard in the receiver for nearly $\frac{3}{4}$ of a mile. Passenger cars can be heard at 300 to 1,000 feet. A clipper almost entirely eliminates this source of trouble and for that reason is an essential part of any mobile short-wave AM receiver.

—end—

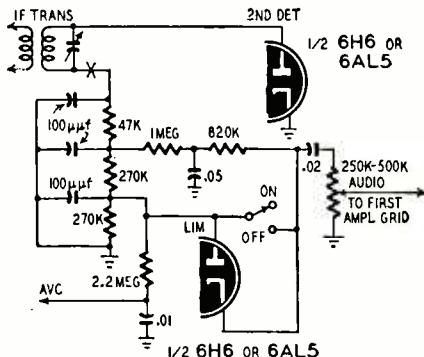

Fig. 7—Noise clipper circuit adaptable to most mobile communications receivers.

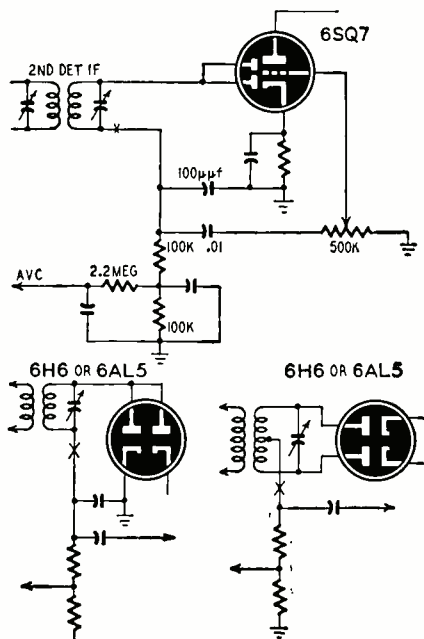

Fig. 8—Methods of connecting the noise clipper to three types of 2nd detector.



**TRAIN FASTER—TRAIN BETTER—TRAIN EASIER
IN 10 MONTHS—OR LESS—FOR
RADIO-TELEVISION**

Our 21st Year Training Men for Greater Incomes and Security in Radio-Television

**I SEND YOU
18 BIG KITS**

of Radio Television parts and equipment. Much of your training will be actual construction and experimentation . . . the kind of truly PRACTICAL instruction that prepares you for your Rad-o-Television career.



Frank L. Sprayberry
President
Sprayberry Academy
of Radio

NEW! NO OBLIGATION PLAN

**You Have No Monthly Payment Contract to Sign
Pay For Your Training as You Earn and Learn**

You can get into Radio-Television, today's fastest growing big money opportunity field, in *months* instead of years! My completely new "package unit" training plan prepares you in as little as 10 months or even less! *No monthly payment contract to sign—thus NO RISK to you!*

This is America's finest, most complete, practical training—gets you ready to handle any practical job in the booming Radio-Television industry. Start your own profitable Radio-Television shop . . . or accept a good paying job. I have trained hundreds of successful Radio-Television technicians during the past 21 years—and stand ready to train you, even if you have no previous experience! Mail coupon and get all the facts—FREE!



**Valuable Equipment Included
With Training**

The new Sprayberry "package" plan includes many big kits of genuine, professional Radio-Television equipment. You perform over 300 demonstrations, experiments and construction projects. You build a powerful 6-tube 2-band radio set, multi-range test meter, signal generator, signal tracer, many other projects. All equipment and lessons are yours to keep . . . you have practically everything you need to set up your own profitable Radio-Television service shop.

Earn Extra Money While You Learn!

All your 10 months of training is IN YOUR HOME in spare hours. Keep on with your present job and income while learning. With each training "package" unit, you receive extra plans and "Business Builder" ideas for spare time Radio-Television jobs. New television stations everywhere, open vast new opportunities for trained Radio-Television Technicians—and those in training. If you expect to be in the armed forces later, there is no better preparation than practical Sprayberry Radio-Television training.

YOU BUILD the Television set and the powerful superhet radio receiver shown above. IN ADDITION to the other test units shown here (many are not shown because of lack of space). All equipment I send you is **YOURS TO KEEP.**

**SPRAYBERRY ACADEMY OF RADIO 111 NORTH CANAL ST.
Dept. 20-N, Chicago 6, Ill.**

**MAIL COUPON
TODAY!
NO OBLIGATION**

**SPRAYBERRY ACADEMY OF RADIO, Dept. 20-N
111 North Canal St., Chicago 6, Ill.**

Please rush to me all information on your 10-MONTH Radio-Television Training Plan. I understand this does not obligate me and that no salesman will call upon me. Be sure to include 3 books FREE.

Name..... Age.....
Address.....
City..... Zone..... State.....

**I invite you to get all the facts—
FREE TO YOU 3 BIG
RADIO-TELEVISION BOOKS**

I want you to have ALL the facts about my new 10-MONTH Radio-Television Training—without cost! Rush coupon for my three big Radio-Television books: "How to Make Money in Radio-Television," PLUS my new illustrated Television Bulletin PLUS an actual sample Sprayberry Lesson—ALL FREE. No obligation and no salesman will call. Mail coupon NOW!



A single antenna system covers all v.h.f. and u.h.f. TV channels by using unique selective filters

ULTRA Q-EE

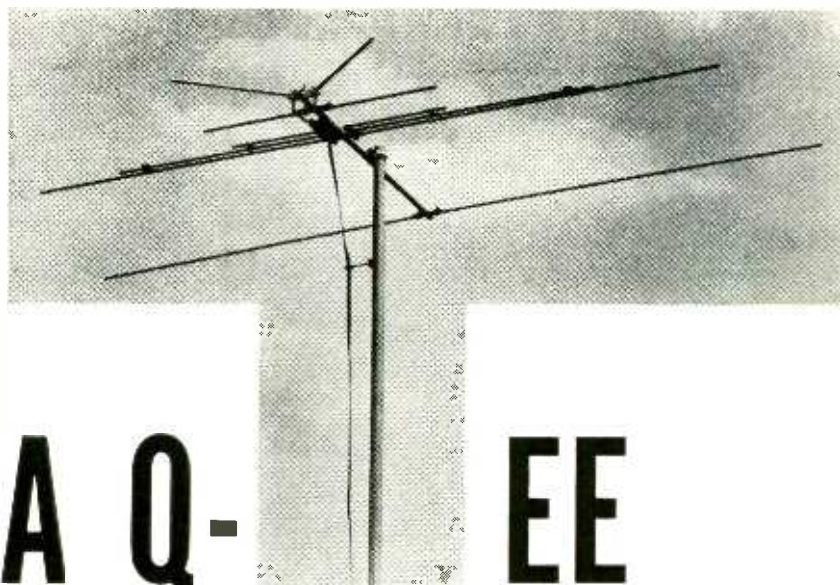

Fig. 1—Horizontal pattern of dipole at fundamental and at third harmonic.

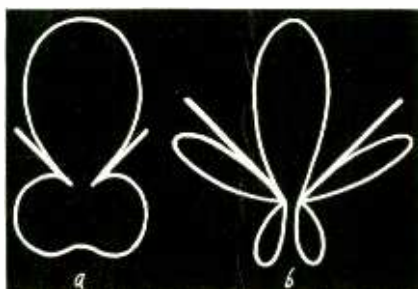
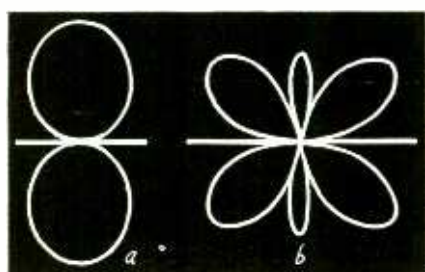

Fig. 2—Radiation pattern of the Fig. 1 dipole with the ends tilted forward.

By DOUGLAS H. CARPENTER*

CERTAIN basic problems concerned with tuner, preamplifier, and antenna equipment have always plagued the TV design engineer. Most of these problems have been created by the inconvenient division of the spectrum into high and low v.h.f. channels. Television receiver front ends have to cover a frequency ratio of almost 4—1. This greatly complicates the design of continuously-tuned types, and increases the cost of efficient tuning mechanisms. Signal boosters of course must also be designed to cover both high and low channels, and losses in optimum performance due to switching have been minimized, but never completely eliminated.

The antenna engineer faces the same basic problems as those faced by the circuit design engineer, but with the additional aggravation of limited working constants. Antenna research has been accelerated by TV, but, until recently, has failed to produce a markedly improved type. Most of the antennas dotting the country's roof tops are simple variations of basic designs described for years in engineering manuals. Installation requirements have generally created a demand for two basic types: broadband systems for multichannel

areas, and selective high-gain antennas for single-channel fringe-area reception. For fringe reception, the Yagi has become well entrenched as the single-channel champion. Where several channels must be received, it is generally conceded that the conical does an outstanding job. For readers not familiar with antenna theory, it might be well to review the principles of that antenna.

Conical antenna operation

A simple half-wave dipole covers a limited frequency range, and has a bidirectional or figure-8 pattern with the planes of maximum radiation at right angles to the directions in which the antenna points. To increase the bandwidth of the simple dipole, it is necessary only to increase its tubular diameter. To further increase bandwidth, an understanding of the familiar "tilt" employed in the conical receiving element is necessary. Fig. 1-a shows the horizontal pattern of a simple half-wave dipole at its design frequency, and Fig. 1-b shows the same dipole at three times this frequency. Fig. 2-a illustrates a receiving element of the same physical dimensions and the same base frequency with the ends tilted. Fig. 2-b indicates horizontal directivity at three times this frequency. The major lobes

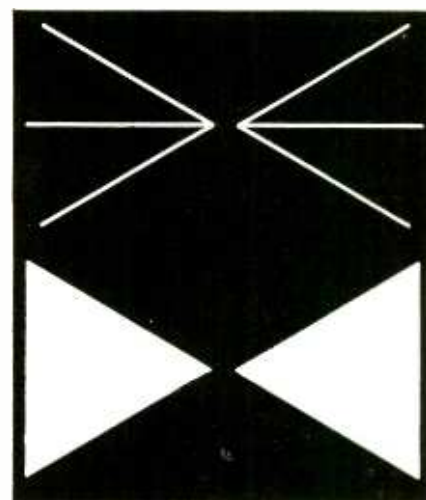

Fig. 3—Evolution of conical antenna.

are superimposed, resulting in increased gain and a sharp horizontal pattern. The 3—1 frequency ratio is roughly that between the high and low v.h.f. television channels. The tilting effect is the basic principle controlling the extended bandwidth of the so-called conical-type antenna. This simple arrangement would work at two preselected frequencies in the television spectrum, but the center impedance of the system would vary radically at frequencies not far from the design and third-harmonic points.

To extend the frequency response around the design points we can electrically simulate a "filled-in" triangular area or solid sheet. This is accomplished in the case of the conical by angularly locating three separate receiving elements on either side of

*Engineering Division, La Pointe-Plascomold Corp., Rockville, Conn.

BUY TEST EQUIPMENT ON THIS RADICALLY NEW TIME PAYMENT PLAN

NO INTEREST!! - NO CARRYING CHARGES!!

USE CONVENIENT TIME PAYMENT ORDER BLANK BELOW

Superior's New

JUNIOR SUPER-METER

MOST COMPLETE AND COMPACT MULTI-SERVICE INSTRUMENT EVER DESIGNED



Measures:
* Voltage * Current * Resistance
* Capacity * Reactance * Inductance
* Decibels

Specifications: D.C. Volts: 0-7.5/75/150/750/1500 Volts. A.C. Volts: 0-15/150/300/1500/3000 Volts. Resistance: 0-10,000/100,000 ohms. 0-10 Megohms. D.C. Current: 0-7.5/75 Ma. 0-7.5 amps. Capacity: .001 Mfd.—2 Mfd. .1 Mfd.—20 Mfd. Electrolytic Leakage: Reads quality of electrolytics at 150 Volt test potential. Decibels: -10 Db to +18 Db. +10 Db to +38 Db. +38 Db. to +58 Db. Reactance: 15 ohms—25 K ohms 15 K ohms—2.5 Megohms. Inductance: .5 Henry—50 Henries 30 Henries—10 K Henries. Plus Good-Bad scale for checking the quality of electrolytic condensers.

Handsome round cornered molded bakelite case 3 1/4" x 5 3/4" x 2 1/4" complete with all test leads and instructions **\$21.40 NET**

Superior's New Model TV-11

TUBE TESTER



• Uses the new self-cleaning Lever Action Switches for individual element testing. Because all elements are numbered according to pin number in the RMA base numbering system, the user can instantly identify which element is under test. Tubes having tapped filaments and tubes with filaments terminating in more than one pin are truly tested with the Model TV-11 as any of the pins may be placed in the neutral position when necessary. • Uses no combination type sockets. Instead individual sockets are used for each type of tube. Thus it is impossible to damage a tube by inserting it in the wrong socket. • Free-moving built-in roll chart provides complete data for all tubes. • Phono jack on front panel for plugging in either phones or external amplifier detects microphonic tubes or noise due to faulty elements and loose external connections.

Operates on 105-130 Volt 60 Cycles A.C. Hand-rubbed oak cabinet complete with portable cover **\$47.50 NET**

Superior's New Model 670-A

SUPER-METER

A combination volt-ohm milliammeter plus capacity reactance inductance and decibel measurements

SPECIFICATIONS:

D.C. VOLTS: 0 to 7.5/15/75/150/750/1,500/7,500 Volts
A.C. VOLTS: 0 to 15/30/150/300/1,500/3,000 Volts
OUTPUT VOLTS: 0 to 15/30/150/300/1,500/3,000 Volts
D.C. CURRENT: 0 to 1.5/15/150 Ma. 0 to 1.5/15 Amperes
RESISTANCE: 0 to 1,000/100,000 Ohms 0 to 10 Megohms
CAPACITY: .001 to 1 Mfd. 1 to 50 Mfd. (Quality test for electrolytics)
REACTANCE: 50 to 2,500 Ohms 2,500 Ohms to 2.5 Megohms
INDUCTANCE: .15 to 7 Henries 7 to 7,000 Henries
DECIBELS: -6 to +18 +14 to +38 +34 to +48



Comes housed in rugged, crackle-finished steel cabinet complete with test leads and operating instructions. Size 6 1/4" x 9 1/2" x 4 1/2".

\$28.40 NET
ADDED FEATURE
The Model 670-A includes a special GOOD-BAD scale for checking the quality of electrolytic condensers at a test potential of 150 Volts

Superior's New

TV BAR GENERATOR

THROWS AN ACTUAL BAR PATTERN ON ANY TV RECEIVER SCREEN!

Two Simple Steps

1. Connect Bar Generator to Antenna Post of any TV Receiver.
2. Plug Line Cord into A. C. Outlet and Throw Switch.

RESULT: A stable never-shifting vertical or horizontal pattern projected on the screen of the TV receiver under test.



Power Supply: 105-125 Volt 60 Cycles. Power Consumption: 20 Watts. Channels: 2-5 on panel. 7-13 by harmonics. Horizontal lines: 4 to 12 (Variable). Vertical lines: 12 (Fixed). Vertical sweep output: 60 Cycles. Horizontal sweep output: 15,750 Cycles.

TV Bar Generator comes complete with shielded leads and detailed operating instructions. Only **\$39.95 NET**

New Model 200-AM and FM

SIGNAL GENERATOR

Provides complete coverage for A.M.-F.M. and TV alignment



R.F. Frequency Ranges: 100 Kilocycles to 150 Megacycles. Modulating Frequency: 400 Cycles. May be used for modulating the R.F. signal. Also available separately. Attenuation: The constant impedance attenuator is isolated from the oscillating circuit by the buffer tube. Output impedance of this model is only 100 ohms. This low impedance reduces losses in the output cable. Oscillatory circuit: Hartley oscillator with cathode follower buffer tube. Frequency stability is assured by modulating the buffer tube. Accuracy: Use of high-Q permeability tuned coils adjusted against 1/10th of 1% standards assures an accuracy of 1% on all ranges from 100 Kilocycles to 10 Megacycles and an accuracy of 2% on the higher frequencies.

* Tubes used: One 954 as oscillator; one 954 as modulated buffer amplifier; T-2 as modulator; 7193 as rectifier.

The Model 200 comes complete with output cable and operating instructions

\$21.85 NET

NEW TIME PAYMENT PLAN ORDER BLANK

MOSS ELECTRONIC DISTRIBUTING CO., INC.
Dept. B-31, 38 Murray Street, New York 7, N. Y.

Please send me the units checked below. I am enclosing the down payment with order and agree to pay the monthly balance as shown. It is understood there will be no carrying, interest or any other charges, provided I send my monthly payments when due. It is further understood that should I fail to make payment when due, the full unpaid balance shall become immediately due and payable.

- JUNIOR SUPER METER Total Price \$21.40
\$5.40 down payment. Balance \$4.00 monthly for 4 months.
- MODEL TV-11 Total Price \$47.50
\$11.50 down payment. Balance \$6.00 monthly for 6 months.
- MODEL 670-A Total Price \$28.40
\$7.40 down payment. Balance \$3.50 monthly for 6 months.
- TELEVISION BAR GENERATOR Total Price \$39.95
\$9.95 down payment. Balance \$5.00 monthly for 6 months.
- MODEL 200 Total Price \$21.85
\$5.85 down payment. Balance \$4.00 monthly for 4 months.

- I enclose \$ _____ as down payment.
- Ship C.O.D. for the down payment.

Signature _____

Name _____

Address _____

City _____

Zone _____

State _____

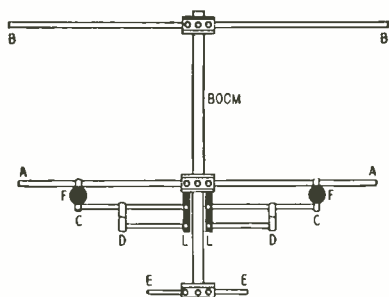

Fig. 4—Details of the Q-Tee antenna.

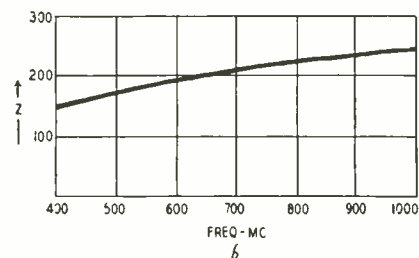
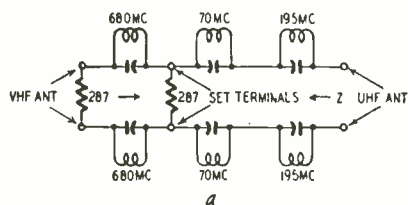
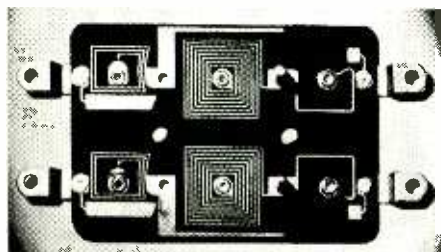

Fig. 5—Schematic and impedance characteristics of the band-isolation filter.



Courtesy Vee-D-X (Lic. A. A. K.)

Fig. 6—The printed-circuit filter which separates u.h.f. and v.h.f. sections.

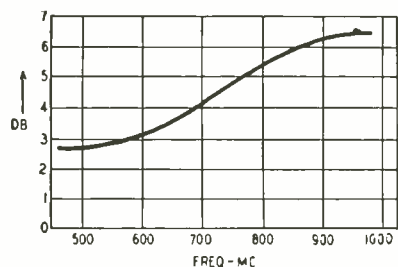

Fig. 7—Ultra Q-Tee gain vs frequency.

the feed junctions so that their fields intercouple, resulting in a lowered Q of the radiator section. This is illustrated in Fig. 3. It will be noted in Figs. 2-a and 2-b that the horizontal pattern of the conical is not ideal throughout the entire v.h.f. spectrum. Tilting the elements displaces the natural directivity response of the dipole, and broadens the pattern on channels 2-6. What actually happens is that the forward response is made worse because of angular separation of the

major natural lobe. This type of antenna is therefore susceptible to increased noise pickup. Signal-to-noise ratio as seen by the front end of the receiving system is directly proportional to the power gain of the antenna and inversely proportional to the width of the horizontal pattern at the frequency under consideration.

Antenna design engineers have thus far found no substitute for natural resonance and sharp horizontal directivity for optimum results. A new approach to the old problem of extending bandwidth while maintaining sharp horizontal directivity has been accomplished by a method quite different from that of the conical types. Fig. 4 is a drawing of the "Q-Tee" antenna. It consists of separate radiator and parasitic elements, coupled with isolation networks which permit independent operation of these separate sections with a common transmission line. B is a half-wave reflector cut for channel 2. Consequently it is effective throughout channels 2-6. Radiator A is also half-wave, with center resonance at 63 mc (channel 3.) Filters F-F are resonant at 195 mc and isolate radiator A from full-wave receiving element C which is cut for the center of the high channels. The T-matching transformer D is tapped into the full-wave receiving element C at a point that converts the impedance characteristic to the transmission line value. Director E is effective over channels 7-13 and has no function on channels 2-6.

If we first consider the operation on channels 2-6 the entire radiator section and reflector B are operative. Tracing from transmission-line feed points L-L, sections D and C "look" like a dual-section T-matching transformer, and match the transmission line impedance to the proper point on the low channel radiator A. Reflector B, as mentioned, controls the horizontal directivity response and center impedance of the radiator section in the low-channel v.h.f. range. Parallel filters F-F are practical short circuits, as they are operating at frequencies remote from resonance. The slight residual series impedance of the filters is utilized in the total match back to the line feed points. Sharp horizontal directivity is obtained by the reflector action, and broad bandwidth by mutual coupling of the elements comprising the total radiator section.

On the high v.h.f. television channels, director E, matching transformer D, full-wave radiator C, and filters F-F control operation. At these frequencies the center impedance of radiator C is dependent upon the spacing of director E. Transformer D matches the line to the proper points of radiator C which is now effectively isolated from the low-channel radiator A by the parallel resonant action of filters F-F. With the u.h.f. spectrum about to go into use, emphasis has been placed on special antennas for higher frequencies. Again, the types used at v.h.f.—if made smaller—become practical at u.h.f. An-

tennas using tilted or V elements can cover a certain broad band of frequencies by taking advantage of the method of Fig. 2-b. Such a system generally restricts the response to a frequency ratio of 3-1.

V.h.f.-u.h.f. antenna

Spreading the frequency acceptance throughout the range of 54-890 mc is possible (at least at this writing) only by selective filtering as employed in the Ultra "Q-Tee" antenna system. Basically, the Ultra "Q-Tee" is an extension of the v.h.f. "Q-Tee" system employing selective separation through the use of a special 6-section printed-circuit filter assembly. Fig. 5 is a schematic of the filter circuit indicating connecting points of the v.h.f. "Q-Tee," transmission line, and u.h.f. antenna section. The problem of simultaneous v.h.f.-u.h.f. operation is solved by isolating the separate receiving elements and delivering all signal voltages to a common transmission line. Fig. 5-a indicates how this is done. Throughout the v.h.f. range, the "Q-Tee" operates as an independent section as described. Shunt loading of the u.h.f. section is eliminated by the parallel-resonant series filters labeled 70 and 195 mc. Filters labeled 680 mc are short circuits to the passage of v.h.f. signals, being designed for the u.h.f. range. Looking toward the load (transmission line) from the u.h.f. antenna, the series filters 70 and 195 mc are short circuits, and filters labeled 680 mc are high impedances isolating the v.h.f. section and permitting independent operation of the u.h.f. antenna. Fig. 5-b shows the average impedance characteristic of the filter throughout the u.h.f. range when properly terminated in average 300-ohm line loads. This information was compiled using a General Radio admittance meter and adjustable "baluns" in the u.h.f. range.

The importance of proper termination at u.h.f. cannot be overemphasized. A slight standing-wave ratio on the transmission line at v.h.f. will not cause a serious amount of signal loss. The fixed constants of the receiver input circuit and antenna termination are much easier to control. Constants that are purely resistive in the lower frequency range develop reactive components in the u.h.f. spectrum. Design of antenna termination, transmission lines, and the eventual receiving system load require much more exacting measurement.

A typical example of the care that must be exercised is a bend in common 300-ohm line at these frequencies. If the bend or impedance variation of the line is an appreciable fraction of a wavelength, a high standing-wave ratio will result. Only a small physical length of line need be altered at u.h.f. to create such a condition.

At this writing, there is no ideal line available for use at u.h.f. Although receiver inputs have been standardized at the 300-ohm figure, present-day lines leave a lot to be desired. Standard ribbon line has an average loss factor of

A Guiding Beacon For
Quality Electronic Parts



Your Local
RADIART
Distributor



RADIART Sales Offices Across The Nation



These Are The Cities With RADIART Distributors
In Connecticut, Maine, Massachusetts, Vermont,
New Hampshire and Rhode Island.

CONNECTICUT

- BRIDGEPORT
- HARTFORD
- MILFORD
- NEW HAVEN
- NEW BRITAIN
- NEW LONDON
- STAMFORD
- WATERBURY

MAINE

- AUBURN
- BANGOR
- PORTLAND

MASSACHUSETTS

- BOSTON
- BROCKTON
- CAMBRIDGE
- FALL RIVER
- FITCHBURG
- HOLYOKE
- LAWRENCE
- MALDEN
- MELROSE
- NATICK
- NEEDHAM
- NEW BEDFORD
- NEWTON

- PITTSFIELD
- ROXBURY
- SPRINGFIELD
- WORCESTER

NEW HAMPSHIRE

- CONCORD
- DOVER
- MANCHESTER

RHODE ISLAND

- PROVIDENCE

VERMONT

- BURLINGTON
- RUTLAND

BUY OF THE MONTH



The RADIART VIBRATOR KIT is the new and wise way to buy vibrators! First of all, you get the BONUS of the re-usable plastic box that has a hundred uses around the home and shop. And of course, you get nine of the famous SEAL VENT vibrators in an assortment that takes care of 60% of ordinary replacement requirements.

FOR NAME OF YOUR NEAREST RADIART DISTRIBUTOR

USE COUPON BELOW

RADIART SALES CO., 90 Edmunds Rd., Wellesley Hills 82, Mass.

-----Please send names of the Radiart Distributors in my area stocking the following Radiart products in which I am interested: Rotors, Vibrators, TV and FM Antennas, "Spee-Dee" Chimney Mounts, Lightning Arresters, Auto Aerials, Power Supplies

-----Please have a Radiart Distributor call on me.

Name

Address

City..... State.....



THE RADIART CORPORATION CLEVELAND 2, OHIO

VIBRATORS • AUTO AERIALS • TV ANTENNAS • ROTATORS • POWER SUPPLIES



Customers judge your service by the results they get. If a radio or TV repair job fails to stand up, they blame *you*, not the parts you used.

Don't jeopardize your business reputation with "just-as-good" replacement parts. OHMITE resistors provide an extra margin of safety. You can depend on these quality resistors—wire-wound or composition—to give years of trouble-free service.



OHMITE MANUFACTURING COMPANY
4895 Flournoy Street, Chicago 44, Illinois

Send for stock catalog

*Be Right
with...*

OHMITE®

DEPENDABLE RESISTANCE UNITS

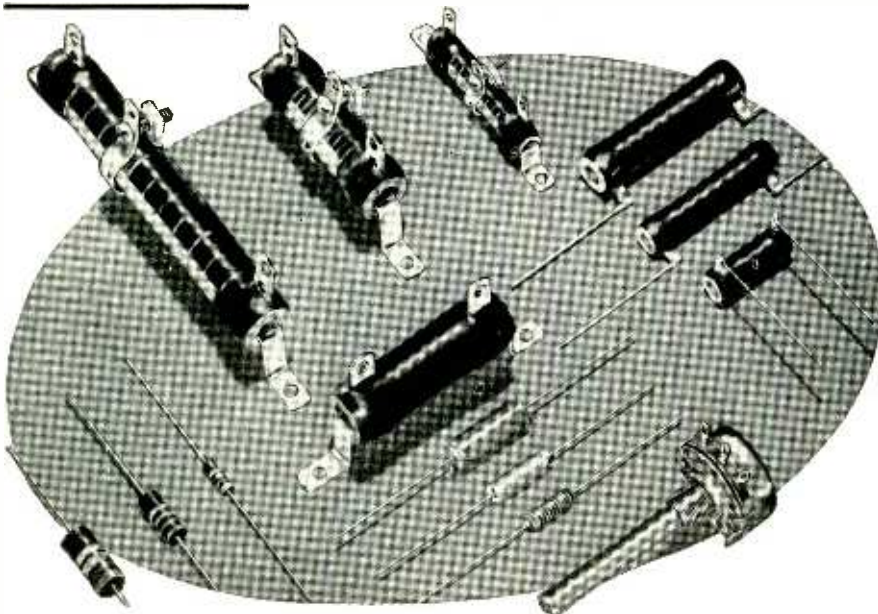

4 db per 100 feet when dry, and between 20 and 30 db when damp. Good grades of coaxial line are less susceptible to moisture absorption, but have a fixed loss of approximately 9 db per 100 feet at the center of the u.h.f. band.

Fig. 6 is a photograph of the printed-circuit filter used in the Ultra "Q-Tee." Printed-circuit technique adapts itself nicely to use in the u.h.f. range, where exact duplication of components is mandatory. More familiar constants of L and C would work as well as the printed-circuit types, but control of tolerances to ½ of 1% would make such an arrangement expensive and impractical from a cost standpoint. Another advantage of the printed-circuit filter over conventional types is the "loading" of the parallel circuits by the composition of the dielectric material. Controlled insertion loss (effective frequency isolation through resonance), and consequently the bandwidth, can be easily controlled by selecting the proper base material. For this specific application phenolic sheet 1/16-inch thick was used. The ratio of L to C must be chosen to provide a definite bandwidth when phenolic material is used as the dielectric.

Another application for the 6-section filter could be isolation of separate antennas for v.h.f. and u.h.f. For this job, it would be installed at the receiver location. Such an arrangement would eliminate a transfer switch for antenna selection.

As will be seen from the photo at the head of this article, the receiving element of the u.h.f. section of the Ultra "Q-Tee," is of the "tilted" or V type. At u.h.f. such design is practical, as we are dealing with one continuous range (470-890 mc). The angle of the V is chosen to superimpose the major lobes exactly at 1,000 mc. The length of the elements comprising the V is cut slightly less than the v.h.f. director. This is to take advantage of the reflector action of this element in the u.h.f. range. At the low end of the u.h.f. range, the V is one-half wavelength on a side and has a fairly high center impedance if considered independently. It is matched through the filter sections. At the one-and-one-half wavelength points, the V has a lower center impedance, but this is compensated for, as far as the transmission line is concerned, by the rising impedance characteristic of the filter itself. (Fig. 5-b). At the two-wavelength point (high end) we have the same impedance-matching problem as at the low-frequency end.

The power gain and directivity of the V-type antenna increases as the number of wavelengths on a leg become greater. The chart of Fig. 7 indicates the gain of the Ultra "Q-Tee" over the entire u.h.f. spectrum as compared to a tuned folded dipole.

Horizontal gain will increase on the average of 2.75 db if two antennas are stacked. This is of course true for both the v.h.f. and u.h.f. sections.

With the impending use of the u.h.f. spectrum, it is felt that the service technician should find wide application for this versatile antenna system.

—end—

Rauland Tubes give you a prettier profit picture



Rauland picture tubes are first choice of an ever growing number of service dealers and men. First, because of the completeness of the Rauland replacement line.

Second, because you get the benefit of acknowledged leadership in picture tube engineering. Rauland research has developed more picture tube improvements since

the war than any other company.

You get quality you can count on, too. Rauland production employs machines unique in the industry—many of them designed by Rauland engineers and built in Rauland's own plant.

And finally, you get assurance of customer satisfaction beyond

what any other line can give you. Installation and adjustment of Rauland tubes is faster and better. The Indicator Ion Trap gives you the surest known protection against ion burn and shortened tube life.

Specify Rauland—deliver Rauland—and assure yourself of pleased picture tube customers.

THE RAULAND CORPORATION



Perfection Through Research

4245 N. KNOX AVENUE • CHICAGO 41, ILLINOIS



Cathode Follower Applications Range From Hi-Fi Audio Circuits To V. H. F.

By I. QUEEN

Compare! PROVE **EMC** SUPERIORITY!

MODEL 205
tube tester

- Tests all tubes including Noval and sub-miniatures
- Completely flexible lever type switching arrangement
- Tests all tubes from .75 volts to 117 filament volts by standard emission test
- Tests all cold cathode, magic eye, voltage regulator and ballast tubes
- Has pilot light indicator
- Line voltage control compensates for line variations between 105 and 135 volts
- Checks for shorts and leakages
- Three-color hammer tone panel.

MODEL 205C—
Sloping Counter Case—illustrated . \$46.50

MODEL 205P—
With hand-rubbed oak carrying case . \$47.50

MODEL 204
tube-battery-ohm capacity tester

- Tests all tubes including Noval and sub-miniature
- Tests all batteries under rated load
- Emission testing method gives easy, direct readings
- Tests resistance to 4 megohms
- Tests condensers from .01 to 1 mfd
- Uses four-position lever type switches
- Checks condenser leakage.

MODEL 204—
Portable oak case, removable cover . \$55.90

MODEL 206
Mutual conductance tube tester

- Checks mutual conductance on calibrated microhmo scale
- Checks tubes for gas content
- Detects both shorted and open elements
- Tests all tubes from .75v to 117 filament volts
- Tests all local, octal and miniature tubes
- Checks individual sections of multi-purpose tubes. Built-in roll chart, Uses lever type switches.

MODEL 206— Sloping Counter Case . \$79.50

MODEL 206P—
With hand-rubbed oak carrying case . . \$83.50

Write Dept. RE-9 for FREE Catalog

Electronic Measurements Corp.
280 Lafayette St., New York 22, N. Y.
Lester Dept. 303 W. 42nd St., N. Y. C.

BOTH BOOKS
FREE

FREE

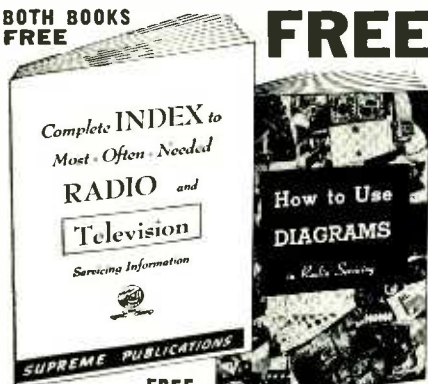

FREE

FREE to every reader of RADIO-ELECTRONICS. No strings, nothing to buy. "How to Use Diagrams" gives hints, suggestions, short cuts on the use of diagrams in radio servicing. The 25-page INDEX will tell you just what models are included in all SUPREME "Most-Often-Needed" Radio or Television manuals. If you need a circuit at any time, this INDEX will tell you where to get it. Get both books in 2-in-1 volume FREE; just send stamp for postage.

SUPREME PUBLICATIONS 3727 W. 13th St. Chicago 23, ILL.

A CATHODE follower is useful in many ways. Most important, its input impedance is higher than the conventional grounded-cathode circuit, while its output impedance is much lower. It is equivalent to a step-down transformer with the advantage that it is effective at high as well as low frequencies. In addition, it is a power amplifier. Because of its impedance characteristics, the cathode follower is ideal for coupling high-gain amplifiers. As a power amplifier, the follower may also be used in an audio output stage.

In a cathode follower the plate is grounded for the signal. This is shown in Fig. 1 where C grounds the plate

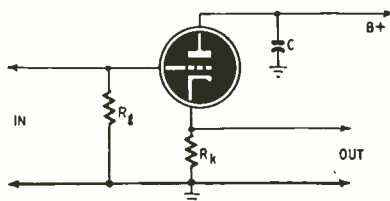

Fig. 1—Basic cathode-follower circuit.

for a.c. The plate may be connected to the B supply directly or through a dropping resistor.

This circuit has 100% negative feedback. The grid and plate circuits return to the cathode through the common load R_k . If the grid goes more positive, more plate current flows through R_k and drives the cathode more positive. Thus part of the original signal is cancelled out. This feedback reduces distortion and permits wider-band operation. Since part of the signal is opposed by the tube output, we can apply larger signals without overload.

The output voltage opposes the input but can never equal it, so the cathode follower is useless as a voltage amplifier. However, there is considerable current flowing through the cathode load and we do have power amplification.

Miller effect is absent in the cathode follower. This effect is the apparent multiplication of input capacitance. It is present only in tubes which show voltage gain. In the follower, the input capacitance is relatively low, therefore the input impedance remains high.

When a tube is used as a cathode follower, strange things happen to its plate resistance (R_p) and amplification factor (μ). The values given in tube manuals apply only to conventional grounded-cathode circuits. For a fol-

lower, the apparent tube resistance is reduced to $R_p/\mu + 1$. This is nearly $1/G_m$, where G_m is the mutual conductance given in mhos. The apparent amplification factor becomes $\mu/\mu + 1$ which is less than unity. This confirms what we said previously about voltage gain. As an example, consider the 6J5 triode. The manual shows: $R_p = 7,700$ ohms, $\mu = 20$, $G_m = .0026$ (mhos). As a cathode follower, the apparent R_p is only $7,700/21$ or 366 ohms. The apparent μ is $20/21$ or 0.95.

The equivalent circuit of a cathode follower is drawn in Fig. 2. The apparent plate resistance shunts the cathode resistor (since both are connected between cathode and ground). The output impedance is less than either R_k or $R_p/\mu + 1$. As shown before, it is always less than $1/G_m$. The next stage (or any other reasonably high-impedance load) will have negligible loading effect on the follower.

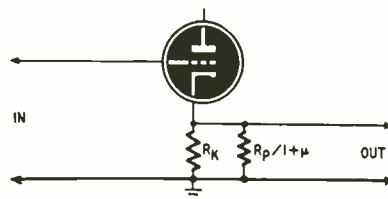

Fig. 2—Equivalent output impedance.

Fig. 3 is a typical arrangement for coupling and isolating high-gain stages. CF1 has a high input impedance so there is negligible loading of the signal source. Its output impedance is low, so AMP1 has practically no effect on the cathode follower. CF2 isolates the amplifiers. Its high input impedance does not load down the previous AMP1. Its output impedance is so low that AMP2 produces no loading effect. Thus a follower effectively isolates amplifier stages. The signal is transmitted easily enough but the stray capacitance of one amplifier cannot combine with that of the next.

If the output load in Fig. 3 were a transmission line or other low impedance, a third follower stage would be used between AMP2 and the load. This permits better impedance match over a wide frequency band.

Fig. 4 is a typical follower used to deliver output at audio and ultrasonic frequencies. It is the output stage of the Hewlett-Packard low-frequency standard (type 100A) effective from 100 cycles to 100 kc. A 1-megohm resistor between plate and grid main-

You can be sure of customer satisfaction-- especially in fringe areas--if the TV set you sell is equipped with a

TARZIAN TUNER

Because so much depends upon the satisfactory performance of the tuning mechanism, many of the nation's leading set manufacturers use the

TARZIAN TUNER

in the television sets they produce, and sell, under their own brand names.

It's only natural that the world's largest producer* of switch-type tuners should produce the best UHF tuners for future, complete coverage reception.

*SARKES TARZIAN, Inc., Tuner Division, Bloomington, Indiana

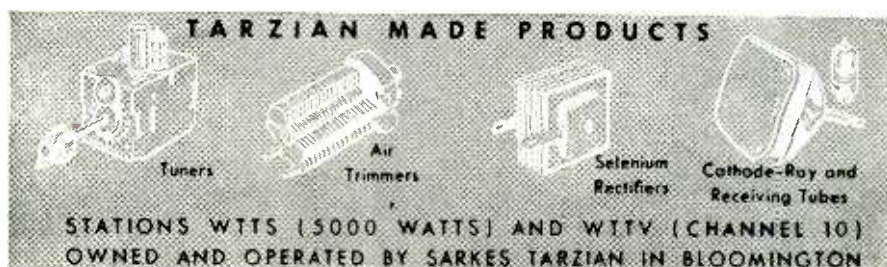
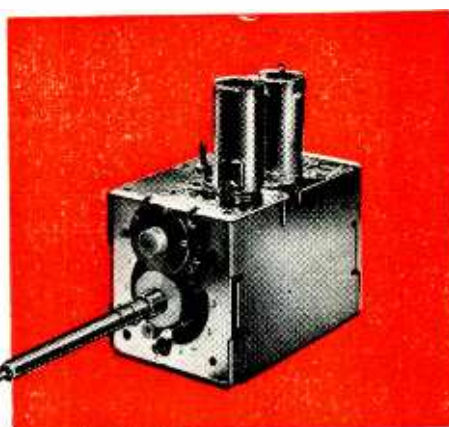

Tarzian Tuners and Tarzian Picture Tubes are available for the growing replacement market. Write for complete information.



C-D's Blue Beaver

- The only electrolytic capacitor designed and built *specifically* for servicemen.
- 50% "safety factor" — makes allowance for changes in set caused by previous servicing, aging of components, etc.
- Eliminates costly comebacks. Millions in use!
- Write for Catalog 200C, Cornell-Dubilier Elec. Corp., South Plainfield, N. J. Your local Classified Phone Directory lists your nearest C-D jobber.

50% tougher
than the job calls for!



CONSISTENTLY DEPENDABLE
CORNELL-DUBILIER
CAPACITORS

PLANTS IN SO. PLAINFIELD, N. J. • NEW BEDFORD WORCESTER AND CAMBRIDGE, MASS. • PROVIDENCE, R. I.
INDIANAPOLIS, IND. • FUQUAY SPRINGS, N. C. • SUBSIDIARY, RADIART CORP., CLEVELAND, OHIO

PARTS LISTS

Bills of material for most of the pieces of equipment described in RADIO-ELECTRONICS construction articles are on hand at all radio parts jobbers and distributors who sell the magazine. See your dealer for a complete parts list of any of this apparatus you wish to construct.

bins the latter positive by 44 volts. Thus a large cathode resistor (5,600 ohms) may be used for maximum output. The 6AC7 is triode-connected. Due to its high mutual conductance, the apparent R_p is low. The load on this circuit may be as low as 1,000 ohms without distortion and with little reduction in output voltage.

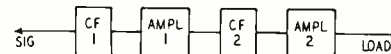

Fig. 2—Cathode followers as isolating stages in high-gain wide-band amplifier.

Fig. 5 is an example of a high-frequency cathode follower. It is the i.f.-v.f. output stage of the RCA WR-59A sweep generator. It delivers 0.1 volt at frequencies up to 30 mc. The 6J6 triodes are parallel-connected. This doubles the effective G_m and results in

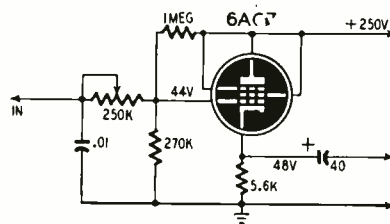

Fig. 4—Schematic of a commercial follower flat from 100 cycles to 100 kc.

still lower *apparent* R_p . Fig. 5 has an output impedance of about 100 ohms. A 100-ohm terminating resistor R is connected across the output cable to eliminate standing waves. The tap at P permits grid bias adjustment.

Although the output impedance of a follower is very low, it is still too high for direct matching to a low-impedance speaker voice coil without using a large number of paralleled tubes.

Fig. 6 shows a cathode-follower audio output stage. The push-pull beam-power tubes are used as triodes. For maximum power output Z_L should equal

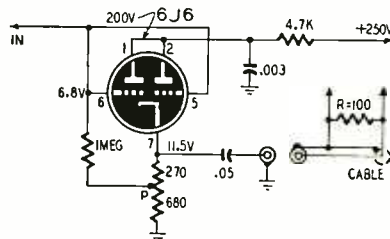

Fig. 5—RCA sweep-generator output stage for frequencies to about 220 mc.

$4 \times R_p / \mu + 1$. For 6L6's this is approximately 1,000 ohms. For maximum *undistorted* output the primary impedance should be about 2000 ohms. With the same input signal, the output power is about $1/\mu$ (where μ is large) as much as in a stage having no feedback. For greater output a peak signal of 150 volts may be fed to each tube in Fig. 6. More than 8 watts output will be available. However, the large signal may require an input transformer, raising the cost and introducing some distortion.

In all the examples shown the tubes are either triodes or pentodes con-

ENGINEERING!

THE POWER

behind
the

EXTRA POWER

of VEE-D-X

Ever since the VEE-D-X name first appeared in the trade, it has been a basic company policy to originate — not to duplicate. As a result, VEE-D-X has contributed more and better products for TV reception than any other antenna and accessories manufacturer. A few of these products are shown below. This record could not have been possible without a highly capable staff of engineers — men who have constantly conducted extensive research and product design programs to bring VEE-D-X users the best in antenna equipment — first. The VEE-D-X engineering staff and facilities are being continually enlarged to meet the challenges of the great and fast-growing TV industry. We say with confidence "Look to VEE-D-X for the newest and most far-reaching contributions to better TV reception."

The World's Most Powerful
TV Antenna Systems

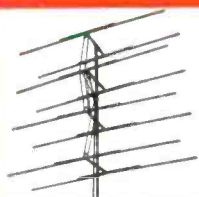

SUPER — First four-bay long distance all-channel antenna.

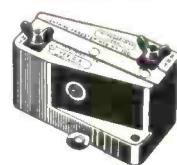

LIGHTNING ARRESTER — The first twin-lead heavy duty lightning arrester.



COLINEAR ARRAY — Low priced, pre-assembled four-bay all-channel antenna.



JC — The original and most popular five element Yagi.



LONG JOHN — Sensational 8 element single channel Yagi.

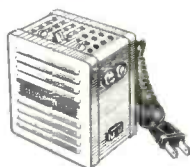

OUTBOARD BOOSTER — The first and most powerful pre-amplifier of its type.



ROCKET BOOSTER — Finest single channel mast-mounted pre-amplifier.



MIGHTY MATCH — Permits use of single transmission line between separate high and low channel antennas.

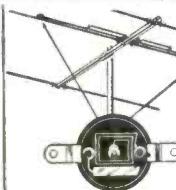

Q-TEE — Revolutionary all-channel antenna with printed circuit channel separators.

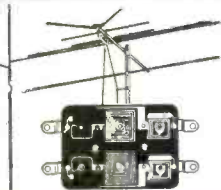

ULTRA Q-TEE(2-83) — The first and only truly all-channel VHF-UHF antenna.

THE LaPOINTE-PLASCOMOLD CORPORATION — New Address — ROCKVILLE, CONNECTICUT

RADIO-TV SERVICE

Get this important **NEW**

Free



one model for all tv sets

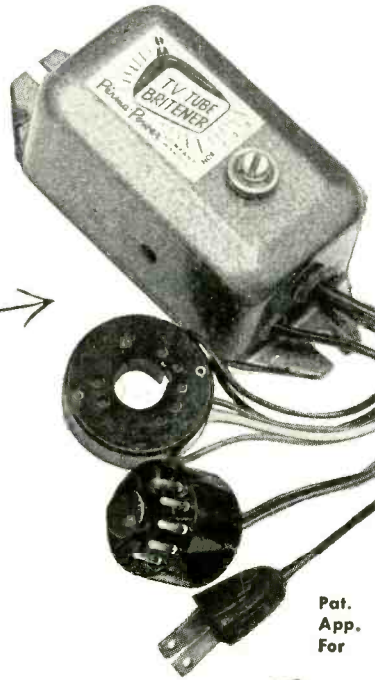

Pat.
App.
For



Order the
Engineered Product
— installs
permanently inside
cabinet in minutes
(no wiring or
soldering) — fully
automatic — 3 boost
positions to
select desired
tube brilliance.

- ★ For either Series — or Parallel-wired filaments.
- ★ Increases electron emission, makes dim tubes **BRITE**
- ★ Isolates filament, relieves cathode-filament shorts.



- ★ Line power supply, does not disturb any TV Set circuits.
- ★ Made to sell, packaged to sell.

Write for complete, illustrated literature.
SOLD through recognized wholesalers ONLY. ORDER TODAY!

Perma-Power COMPANY
4721 N. Damen Ave., Chicago 25, Ill.

"Manufacturers
of electronic
equipment
since 1928"

nected as triodes. It is not practical to use a straight pentode. Since the plate is grounded, this element and the screen grid (which is always grounded through a capacitor) are effectively strapped together.

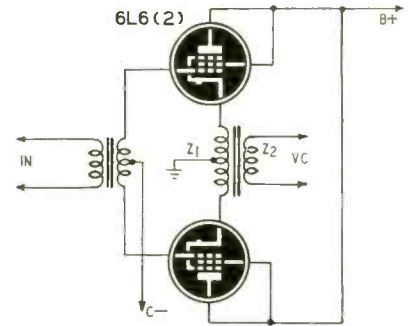

Fig. 6—Push-pull audio power amplifier with cathode-coupled output transformer.

The output from a cathode follower has the same polarity as the input signal. A more positive voltage on the grid increases the plate current and makes the cathode more positive, therefore input and output are always in phase.

The use of cathode followers in audio output circuits may take a new direction in the near future. With the development of high-impedance speaker voice coils, it may be possible to eliminate the output transformer entirely. Balanced voice-coil windings could replace the output-transformer primary in Fig. 6. The magnetizing effect of the d.c. cathode currents is cancelled by the fact that in a perfectly balanced stage, equal currents flow in opposite directions from the center tap. The heating effect of the d.c. remains, however, and reduces the speaker's power-handling ability. One of the problems still facing speaker designers is how to dissipate the heat without increasing the size of the voice-coil structure or the size of the magnetic gap.

—end—



"I'm the radio ham of this outfit. I get the short wave!"

HERE YOU ARE, SERVICEMEN!

Win \$5,000.00 in cash prizes!

Jensen
NEEDLE'S

\$1000 FIRST PRIZE!

187 WINNERS!

187
CASH PRIZES

1st Prize	\$1000.00
2nd Prize	500.00
3rd Prize	250.00
Next 10 Winners . . . each	100.00
Next 25 Winners . . . each	50.00
Next 50 Winners . . . each	10.00
Next 100 Winners . . . each	5.00
Total Prizes	\$5000.00

Contest Closes
DEC. 31, 1952

"WIN
A GRAND"
CONTEST

Special Prize
FOR EARLY BIRDS!

A precision quality, high powered Jensen Needle Microscope will be given to each of the first 500 servicemen to send in a completed Official Entry Blank. \$5.00 value. Handy pocket size to take on your service calls.

Start saving those packages . . . get your entry in soon!

RULES OF ENTRY

1. What You Have To Do . . . Jensen Phonograph Needles are packaged two ways—on a card or in a plastic box. Every time you sell or install a Jensen Needle during this contest, save the card or colored insert in the box (not the instruction sheet). Collect as many as you can during the contest period. Prizes will be awarded to the 187 servicemen sending in the most empty Jensen Needle packages.

2. When Is The Contest . . . The Jensen "Win a Grand" Contest opens September 1, 1952 and closes at midnight December 31, 1952.

3. Who Is Eligible . . . This contest is open to every bona fide radio-television serviceman in continental United States. This includes employees as well as employers, anyone who is actively engaged in this work during the period of the contest. No employee of Jensen Industries, Inc. or its advertising agency is eligible.

4. How To Enter . . . To be eligible for one of the 187 cash prizes, you must send in one completed Official Entry Blank (available at your regular Parts Distributor) together with all the empty Jensen Needle packages you have collected during the period of the contest. All Jensen Needle packages, EXCEPT the Jensen "Symphonette" and Jensen Coin Machine Needles, are acceptable.

5. 15-Word Statement . . . On the Official Entry Blank, you will find a sentence beginning, "I Sell Jensen Needles Because" Just complete this sentence in 15 words or less. As a suggestion, you might say, "I Sell Jensen Needles Because they are easier to install." (5 words).

6. Where To Send Entries . . . All entries to be considered for prizes must be sent, accompanied by a completed Official Entry Blank, direct to:

Jensen Contest Headquarters, 329 South Wood St., Chicago 12, Illinois

Do not send your entry to your Parts Distributor. You may hold your entry until the last day or send it in as often as you like, but be sure you have a suitable means of identification with each shipment (such as your original Official Entry Blank). REMEMBER: All entries must be postmarked before Midnight, December 31, 1952, to be eligible.

7. Duplicate Prizes . . . In the event of a tie, duplicate cash prizes will be awarded to all tying contestants.

8. Judges' Decision Final . . . Decision of the judges, chosen by Jensen Industries, Inc., will be final. All entries become the property of Jensen Industries, Inc., and none will be returned.

9. Only Entry Itself Counts . . . Only the total number of empty Jensen Needle packages, together with the completed Official Entry Blank, counts toward the prizes. Neatness, spelling, grammar or packing of entry do not count.

10. Winners To Be Announced . . . Winners in the Jensen Contest will be notified as soon after the contest closes as possible.

HERE'S ALL YOU HAVE TO DO! . . .

It's Easy! Simply save the cards and colored inserts from all the Jensen Phono Needles you sell or install from now 'til the end of the year. Pick up an Official Entry Blank at your regular Parts Distributor, complete the sentence, "I Sell Jensen Needles Because" and mail this with your packages direct to Jensen Contest Headquarters before Midnight December 31st. That's all there is to it . . . the radio-TV serviceman sending in the most Jensen packages wins \$1000 cash. It might be you!

WHY JENSEN SPONSORS THIS BIG CONTEST!

Every radio-television serviceman can get a lot more business for himself without additional tools, equipment or labor simply by just replacing worn-out phonograph needles. That's why Jensen sponsors this unique contest—to show you how easy it is . . . and profitable, too. And Jensen supplies every assistance you need, with a precision made needle for every type of record player and complete easy-to-follow instructions.

Jensen INDUSTRIES, INC.
329 South Wood Street, Chicago 12, Illinois

JENSEN . . . Oldest name in Sound Engineering

Sell a JENSEN NEEDLE on Every Service Call!

Depend on ...
CONCORD
 for BEST
VALUES!

RED HOT BUY!
 Famous Make
CLOCK RADIO

Superhet. Self-starting
 clock - sweep - second
 movement. Molded
 plastic cabinet. Ebony.
 Lots of 3, **\$15.95**
 Each
 Single, each \$16.95



Walnut, lots of 3,
 Each \$16.95
 Single, Each \$17.95



EXTRA! EXTRA!
NATIONAL
"Turret"
TV BOOSTER

Finest ever made!..
 Self-contained, in ma-
 hogony finished metal cabinet.

Limited
 quantity!

Special Reg. List \$39.95
 Net. each **\$11.95**

Yes, you'll find these wonder-
 ful buys — and thousands more,
 in the new **CONCORD** Buying
 Guide.

DEPEND ON CONCORD, for:

- The latest in Radio, Electronic & TV Sets, Sound Systems, Ham Equipment, Components, Accessories, Standard Merchandise and **SPECIAL BUYS!**
- Fast, efficient, courteous Counter Service — High-geared Mail-order Department — a Ham Section manned by **HAMS**, ready to help you!

Send **TODAY** for your copy of our
 latest Buyer's Guide.

CONCORD RADIO
 55 Vesey St., New York 7.

VALUES GALORE!
 • RADIO
 • TELEVISION
 • ELECTRONIC
BUYER'S GUIDE
CONCORD
 RADIO

and it's
FREE
 for the
 asking

CONCORD RADIO, 55 Vesey St., N. Y. 7
 Dept. C-9
 Send me at once your latest Buyer's Guide,
 Free of Charge.

Name

Address

City State

AUTOMATIC VOLTAGE REGULATION FOR R.F. HIGH-VOLTAGE SUPPLIES

By **ALFRED HAAS**

RF. power supplies of the type shown in Fig. 1 are widely used in television, oscilloscopes, radiation counters, and other devices that require very high voltages at currents up to about 1 ma. Compared with line-frequency transformer-rectifiers, they have the advantages of low cost, small size and weight, and safety, but the voltage regulation is generally poor for two reasons:

1. The high d.c. resistance of the rectifier and filter causes large changes in output voltage with changes in load.

2. The oscillator tuning is also affected by changes in load. The filter capacitor (C_F) and the internal capacitance of the rectifier (C_R) are part of the tank circuit. A change in load current becomes effectively a change in tuning capacitance. The oscillator resonance curve (Fig. 2) is generally quite steep, as high-Q tank circuits are used for efficiency and high output. If the oscillator is normally tuned to the peak of the resonance curve, the detuning effect of a change in load will cause a large drop in r.f. voltage and a decrease in the rectified output.

(In unregulated circuits this effect is kept as low as possible by tuning the oscillator to a frequency on the *relatively flat* high side of the resonance curve. The maximum output voltage is reduced, but regulation is improved.)

A recent French invention utilizes the electrostatic attraction between the plates of a capacitor as an automatic voltage regulator. When a capacitor is charged, the positive and negative polarities tend to pull the opposite plates together. In ordinary capacitors, the physical barrier of the dielectric,

proportional to the voltage.

If one of the capacitor plates is flexible, an increase in applied voltage will bend it toward the fixed plate and increase the capacitance. A reduction in voltage will reduce the attraction and

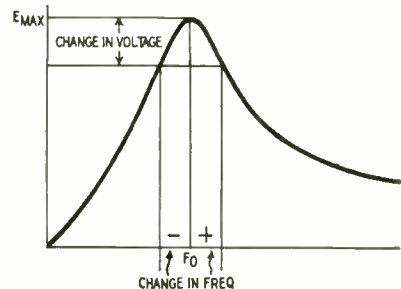

Fig. 2—H.v.-oscillator output curve.

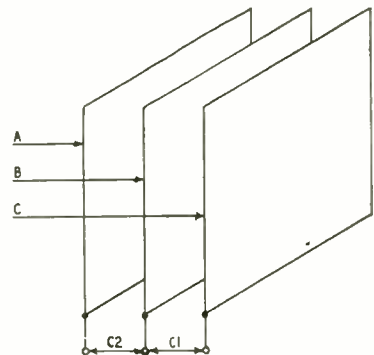

Fig. 3—The automatic voltage-regulating capacitor described in the text.

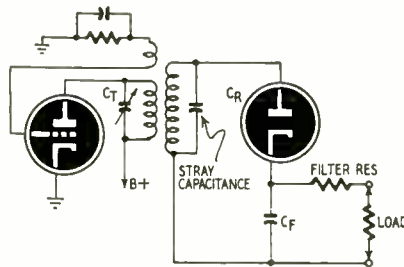

Fig. 1—Basic circuit of most r.f.-oscillator-type high-voltage power supplies.

or in air capacitors the rigid mounting, prevents any actual movement of the plates. The attracting force is directly

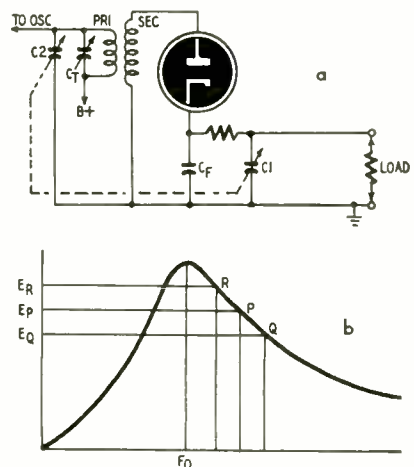
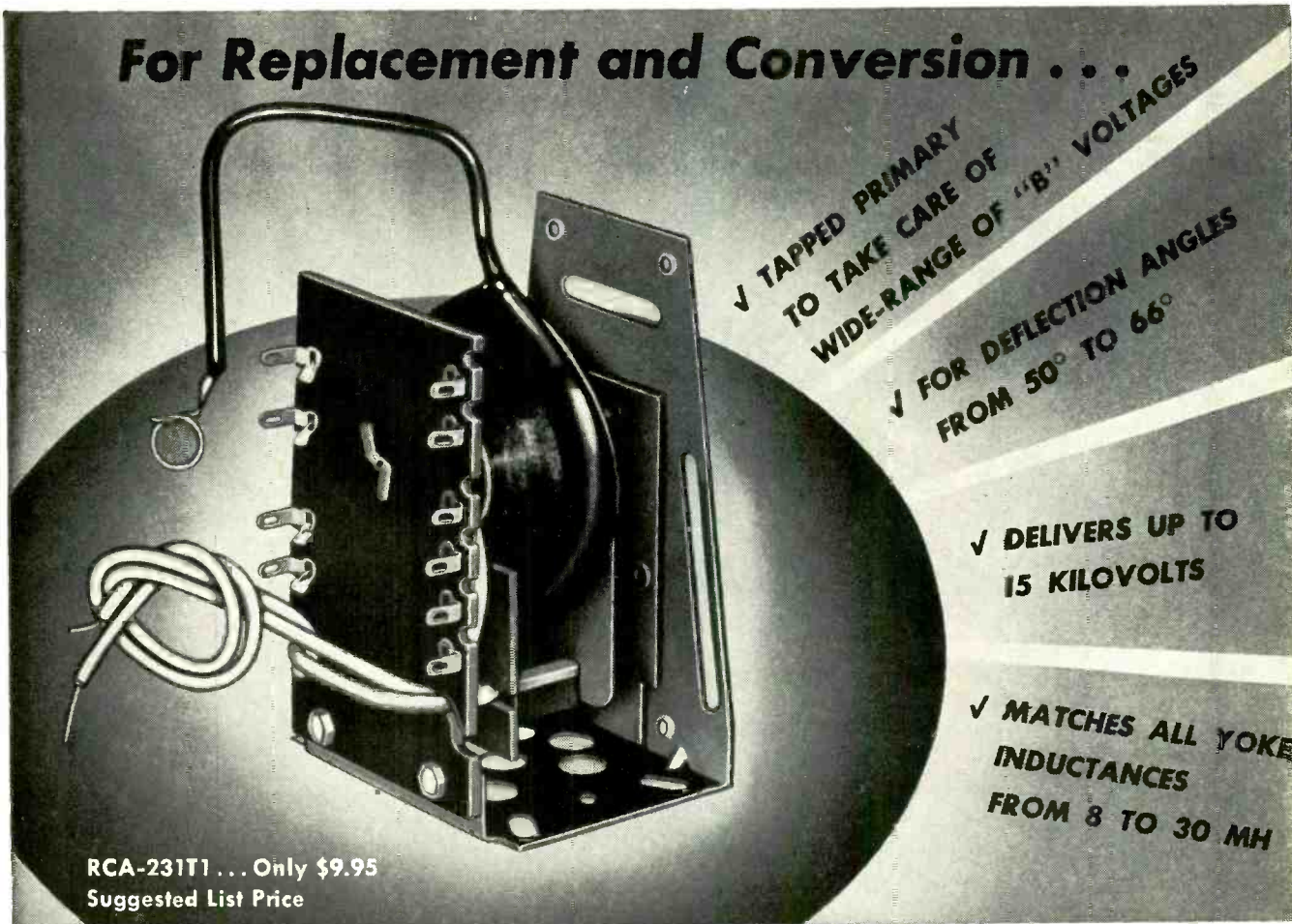

Fig. 4—(a) Positions of regulating-capacitor sections C1 and C2 in the circuit. (b) Operating characteristics of the new automatic voltage regulator.

For Replacement and Conversion . . .



RCA-231T1 . . . Only \$9.95
Suggested List Price

✓ TAPPED PRIMARY
TO TAKE CARE OF
WIDE-RANGE OF "B" VOLTAGES

✓ FOR DEFLECTION ANGLES
FROM 50° TO 66°

✓ DELIVERS UP TO
15 KILOVOLTS

✓ MATCHES ALL YOKE
INDUCTANCES
FROM 8 TO 30 MH

NOW . . . a "universal-type" horizontal output & HV transformer

You've wanted it . . . here it is—the first "universal-type" horizontal output and HV transformer that solves virtually all replacement problems in TV receivers utilizing transformers which have isolated secondary windings. Because of its versatility, this new transformer is particularly suitable for conversion jobs.

Mechanically and electrically . . . the new RCA-231T1 meets practically every mounting and circuit requirement. With its 3 terminals on the primary winding and 7 terminals on the secondary winding, this universal-type transformer accommodates all standard driver tubes . . . assures a flexible and accurate match to an extremely wide range of yoke inductances . . . and provides excellent voltage regulation, ample width, and high voltage output. It uses a ferrite core for highest efficiency, cushioned to reduce 15-Kc acoustic radiation . . . and an arc shield to minimize corona problems. Provided with multiple mounting holes and slots, the RCA-231T1 can be quickly installed in practically all receivers.

Now, for the first time, you can simplify your stocking and servicing problems, with the new RCA-231T1 transformer for receivers using isolated-secondary-type transformers. Save yourself time and trouble . . . get a supply of 231T1's from your RCA Parts Distributor *today*.



RCA-201Y1
Convertkit
Only \$19.70 Suggested List Price

Handles picture tubes up to 21 inches in size and having horizontal-deflection angles up to 66°. Contains high-quality electronic components—an RCA-211D2 "Anastigmatic" Deflecting Yoke and an RCA-231T1 Horizontal-Deflection-Output and High-Voltage Transformer.

See your local RCA Parts Distributor for "Original" RCA TV Components.

tmks. ®



RADIO CORPORATION of AMERICA
ELECTRONIC COMPONENTS HARRISON, N. J.

don't throw it away...
weak picture tubes can be saved!

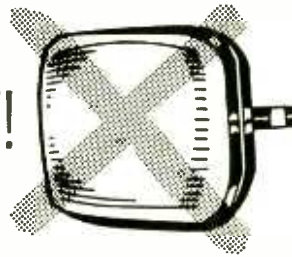

use a
**Picture Tube
REJUVENATOR**

- ✓ Simple Plug-in Unit
- ✓ Permanent Hook-up
- ✓ No Exposed Wires
- ✓ Usable on All Size Tubes
- ✓ Automatically Operated
- ✓ Only \$2.79 Dealer Net

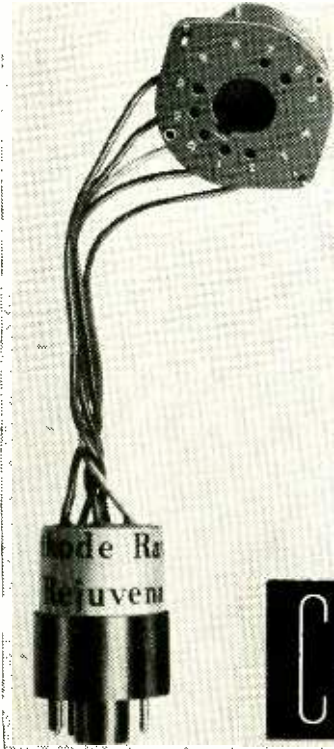

Model "C"



Available at Local Jobbers

LABORATORIES, INC.

Whitehall Building
Far Rockaway, New York

the flexible plate will move away.

The new invention (Fig. 3) consists of a special capacitor with two fixed plates (A and C), and a single flexible plate (B). The capacitance BC (C1) is across the load; capacitance AB (C2) is part of the oscillator tank (Fig. 4-a). The oscillator is tuned to frequency P on the high-frequency side of the resonance curve (Fig. 4-b).

If the load voltage increases for any reason from its normal value at P to a new value represented by R, plate B of the special capacitor will be attracted toward C. This reduces the capacitance between B and A (C2) and automatically retunes the oscillator to the original frequency P, reducing the output voltage. Any drop in load voltage (Q) bends plate B away from C and closer to A, increasing C2 and tuning the oscillator back toward P.

In one form of the new device movable plate B may be a small vane attached to the pointer of a voltmeter across the load. The fixed plates A and C may be mounted on either side of the normal-output scale reading. Proper damping of the meter pointer and vane B will prevent sudden changes and "hunting".

—end—

NEW TUBES

Sample quantities of 27-inch rectangular picture tubes are being produced by RCA and Sylvania for set manufacturers working on 1953 models. No RTMA type numbers have been issued yet for these tubes. The RCA version is a metal-shell tube weighing 29 pounds, with aluminized screen and spherical frosted-Filterglas faceplate.

New! Up-to-date!

**TELEVISION
SERVICING**

by Walter H. Buchsbaum

Get this brand new, complete handbook for sure-fire working knowledge of TV installation, maintenance and troubleshooting. Tells you step-by-step procedures for audio IF alignment, video IF alignment, aligning RF amplifiers, mixers, oscillators, etc. All possible defects classified for ready reference, thoroughly analyzed to show what is wrong and why... and what to do to correct the defect. No mathematical knowledge needed! Practical, authoritative, up-to-the minute, the perfect handbook for set owners, trainees, and repairmen.



340 pages
170 illustrations

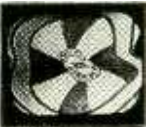

Symptoms of defective operation easily recognized, quickly corrected by illustrations, diagrams and how-to-do-it facts in this new book.

USE IT 10 DAYS FREE

Coupon below brings you "Television Servicing" on FREE trial for 10 days, without obligation. Mail it NOW.

PRENTICE-HALL, Inc., Dept. M-RE-952
70 Fifth Ave., New York 11, N. Y.

Send me, for 10 DAYS' FREE TRIAL, "Television Servicing." I will return it in ten days and pay nothing—or keep it and send \$1.35 down (plus postage) and \$2 monthly for 2 months.

NAME.....
ADDRESS.....
CITY.....STATE.....

SAVE! Send \$5.35 with this coupon, and we'll pay postage and packing.

Crystal Headphones (Brush) . . . 50,000 Ω Imped. . . \$4.95
With adj. band & tipped cord . . . operate to
Sound-Power Phone-Mike Units . . . ea. \$1.95 2/3.49
250 ft. using only 2 cond. wire . . . ea. \$1.95 2/3.49

Leotone

- 20 Ft. Speaker Ext. Cord . . . tip-lug69
- 6V AC-DC Plunger Solenoid (1 1/2"x1 1/2" O.D.)89
- 3/8" travelea. 89¢ 6/4.95
- 5" C.R. Tube Front Bezel . . . black crackle89
- 5" Scope Visor . . . leather; rubber eye-piece98
- Radio Hardware Treasure . . . FULL I.B. CAN (hinged lid) of: NUTS, WASHERS, LUGS, SCREWS, Eyelets, etc.lb. 89¢ 3 lbs./2.49
- ARC-5 P.A. Xmt'r Coil (#27250) . . . 7-9Mc.98
- Dynamic Headset & Hand Mike (#19-MKH)3.49
- Press-to-talk, BRAND NEW
- HB-7 Headbands . . . dble. cord, less plug10/3.50
- Used surplusea. 29¢ 10/2.49
- NE-48 Neon Bulbsea. 29¢ 10/2.49

!!TUBE CLEARANCE SALE!!
90 DAY GUARANTEE!
Standard brands; unsealed cartons—
80, 85, 89 or 6K725¢
#1H4, 1H6, 1J6, 6B7, 6G5, 6SD7, 6SH7 or 6R739¢
#7, 7B, 1L4, 5Y3, 5Y4, 6F6, 6J5, 6K8, 6SA7, 6SK7, 6C5, 6U7 or 7B959¢
#1A7, 1LC6, 1LH4, 2A5, 2A6, 6A3, 6A6, 6B8, 6SC7, 7A7, 7AG7, 7C6, 7C7, 7Y4 or 5Y69¢

High Fidelity Crystal Mike . . . hi-imped. Rubber shock mtd. 1 3/4"x1 1/4". Less housing\$1.29
Aluminum Housing for crystal mike15
Hand Mike Case . . . moulded bakelite98
12 1/2 Ft. Whip Antenna . . . 4 steel screw sects.1.98
3.9MFD-330VAC Oil Condensers98



!!MOTOR SPECIAL!! . . . 1/17H.P.
G. E. MOTOR, 1725RPM, 110VDC.
7amp. Dble. 3/8" shaft.
O.D. 3 1/2"x5 1/2". Shpg. wt. \$2.95
13 lbs.ONLY

Ball Bearings (Fafnir) . . . O.D. 3/4", I.D. 3/16"29¢ 4/1.90
O.D. 5/8", I.D. 1/8"23¢ 5/1.00
Cabinet Draw Slidessliding ball-bearing13" (9" ext.)—\$2.10 pr.; 25" (11" ext.)—\$2.25;
16 1/2" (12 1/2")2.39
16 1/2" (12 1/2")3.25
Experimental Tubes . . . for Test, Research, etc.
Fil. tested. Kit of 40 asstd. revg. types.1.98

STOP! LOOK! SAVE!! "JUMBO RADIO PARTS KIT" . . . 17 FULL LBS. OF EVERYTHING FOR THE RADIOMAN: COILS, CONDENSERS, SWITCHES, RESISTORS, CONTROLS, HARDWARE, WIRE plus MUCH, MUCH, MUCH MORE! (shpg. wt. 20 lbs.)\$3.95

Moulded Bakelite Condensers00002 to .2mfd., 200-000V. Micamold. Kit of 50 asstd. \$1.98
Carbon Resistors . . . 1/2 to 2W, 100 asstd.1.98

"FACTORY SPEAKER REPAIRS SINCE 1927"
Min. order \$3.00, 20% deposit req. on all C.O.D.'s. Full remittance with foreign orders. Please add sufficient postage—excess refunded.

LEOTONE RADIO CORP.
67 Dey Street
New York 7, N. Y.



Sylvania's (shown above) is all glass, with a neutral-density gray-filter face plate. It uses magnetic deflection and focus, and has no external conductive coating. Recommended operating conditions for the Sylvania tube are: ultor voltage—20,000; grid 2 voltage—300; ion-trap magnet—45 gauss.

Both types are shorter than 21-inch picture tubes, and have 90-degree deflection. Screen size is approximately 18 x 24, with a picture area of about 400 square inches. Basing is standard.

—end—



TESTING TUBES PAID FOR OUR *HICKOK* 605 IN LESS THAN A WEEK

Bill Schneider

Fairview Radio & TV Service
Fairview Park 26, Ohio

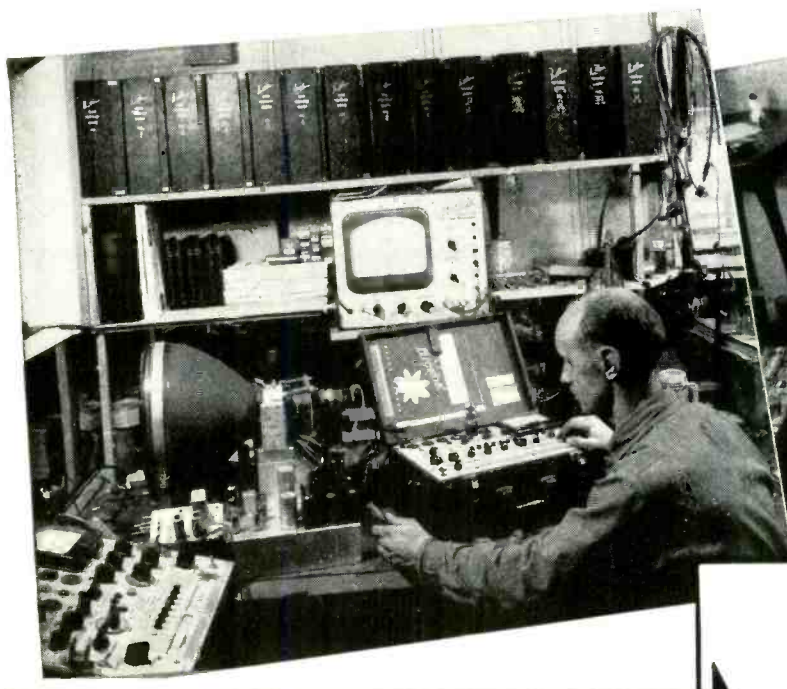

An average of 8 tubes will fail in a TV receiver every 6 months.

Read what Bill Schneider writes:

"Due to the highly efficient circuits of today's TV receivers, their Vacuum tubes are constantly pressed to their upper limits. In order to produce a sharp clear picture these circuits must function perfectly at all times.

In our service work we find that every 6 months an average of 8 tubes fall below requirement standards in every TV receiver, due to use. Hickok tube testers are the only instruments to contain the dependable completeness of test necessary to accurately pick out below normal tubes. All tubes that the Hickok testers reject should be replaced to bring the receiver back to its manufacturer's standards.

We have continued to stand on the accuracy of our Hickok 533 and 534A shop testers for any tube test, so we decided to invest in another Hickok to build our income with increased "house-call" business. We chose the Hickok 605 tube tester because of its multimeter. For \$12.60 more than the standard Hickok we got a built-in multimeter with a vacuum tube rectifier which is better than any other V.O.M. we could buy separately; even up to \$50.00 as it will also measure capacitance. The complete Hickok 605 cost \$167.60. With it we replaced

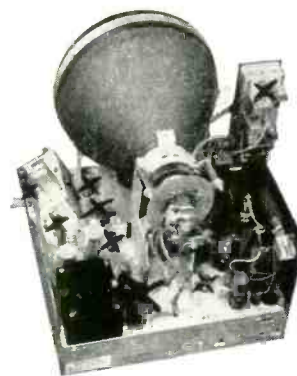

235 tubes in the first week of part time use. The profit on these tubes alone covered the cost of the 605 and gave us an additional small income on top of it. Our new, fast and accurate service has added many customers by way of recommendation, as well as a healthy increase in our shop service on more complete jobs.

As a special note, we have been averaging over 200 tubes a week ever since."

Sincerely, Bill Schneider.

MODEL 605 \$167.60

WRITE TODAY FOR COMPLETE INFORMATION

THE HICKOK ELECTRICAL INSTRUMENT COMPANY

10531 DUPONT AVENUE • CLEVELAND 8, OHIO

THE STANDARD OF QUALITY FOR OVER 40 YEARS

This instrument provides complete sweep and marker frequencies

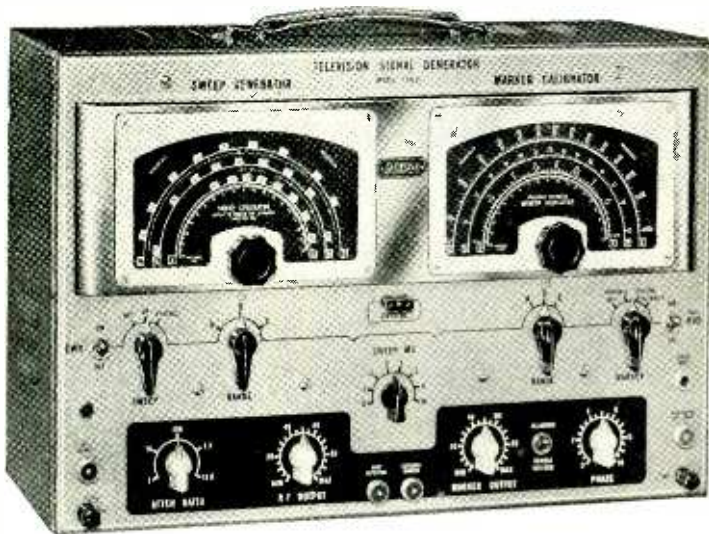

Jackson Model TVG-2 Television Generator

Both industrial and service technicians the world over use the Model TVG-2. Years of experience have proved that Jackson Signal Generators STAY accurate. Just ask the "ole timer" who owns one.

Continuously variable sweep frequencies over all TV and FM bands . . . Reversible single response pattern with base line or double pattern . . . Adjustable sweep width from 100 KC thru 18 MC . . . Marker Calibrator continuously variable from 100 KC thru 216 MC . . . Separate Crystal Oscillator for use either as a marker or calibrator . . . Video Modulation Jack provides for picture or pattern

modulation . . . Marker Calibrator IF frequencies all on highly stable fundamentals . . . RF Output completely controllable with variable and step attenuator . . . Multiple shielding of attenuators and circuits insures low leakage . . . Complete Sweep and Marker Generators in one beautiful instrument . . . Styled to match the famous Jackson Model CRO-2 Oscilloscope.

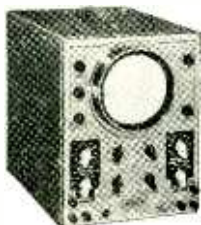

MODEL CRO-2
OSCILLOSCOPE

Two Other Fine
Jackson Instruments

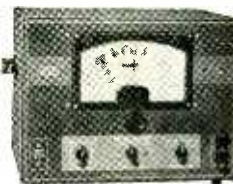

MODEL 655
AUDIO OSCILLATOR

5-inch oscilloscope having a vertical sensitivity of .018 RMS v.p.i. and band width flat within 1.5 db from 20 cycles thru 4.5 Mc. Linear sawtooth sweep oscillator 20 cycles thru 50 KC per second in 5 steps. A standard voltage provided for determining unknown Peak to Peak potentials of all waveforms. Has reversible vertical polarity and return trace blanking.

Sine-wave 20 cycles to 200,000 cycles. Less than 5% harmonic distortion between 30 cycles and 15,000 cycles. Frequency calibration accurate within 3% or 1 cycle. Hum level down more than 60 db of maximum power output. Output impedances of 10, 250, 500, 5000 ohms or Hi Z resistive output.

See your electronics distributors for more information, or write

JACKSON ELECTRICAL INSTRUMENT CO.

"Service Engineered"
Test Equipment

DAYTON 2, OHIO

In Canada:
The Canadian Marconi Co

AIMS AND OBJECTIVES OF A TECHNICIANS' GROUP

We have printed a number of *Codes of Ethics* of electronic service associations. The *Statement of Aims* below is considerably broader, since it includes the objectives as well as the ethical standards of the organization. It forms part of the constitution of the San Diego County Electronic Association:

We, the electronic technicians of San Diego County, deem it eminently right that we should organize for the development and improvement of our conditions, taking but a fair and just compensation, commensurate with the services rendered, so that equity may be maintained and the welfare of our Association be promoted. To this end the following objectives are promulgated:

To establish, promote and maintain a high standard of ethics, integrity, business practice, and service among members of this association.

To accept as members of this association only those people who will pledge themselves to uphold the standards, unity, and integrity of this association. To publicize the ideals and objectives of this association for the purpose of inspiring public confidence.

To act as liaison between the public and members of this association.

To act as arbitrator in cases of public complaint involving members of this association.

To encompass a training program which will ensure the public of fully qualified technicians.

To assist civic groups and organizations to the best of our abilities.

To provide adequate apprenticeship training with proper supervision within this association.

To ensure the public of a flexible association which can readily modify its program as circumstances demand.

To foster close co-operation between members of this association with mutual support extended to every member.

To provide the public with a source of



"Since he discovered that old crystal set up in the attic, he hasn't any time for television!"

RADIO-ELECTRONICS

**\$4⁰⁰ opens up
A NEW BUSINESS
FOR YOU...**

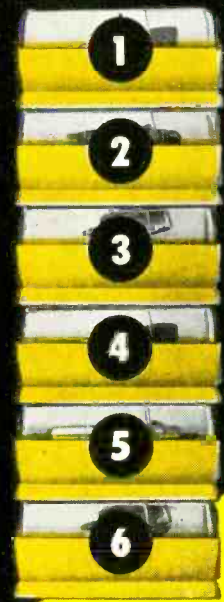

**GOLDEN OPPORTUNITY FOR ALERT SERVICEMEN
TO TURN \$4.00 INTO HUNDREDS**

The market is wide-open... a ready market... an actual \$70,000,000 Phono-Cartridge Replacement market. Facts and figures prove it! What an opportunity for you and every serviceman to get new business, profitable business you're not getting now!

ELECTRO-VOICE SHOWS YOU HOW... AND PAVES THE WAY

E-V helps you with everything you need to build a money-making Professional Phono Service business—New Sales Aid Kit, Manufacturer's Set Model Replacement Guide, Dramatic Direct Mail Campaign including Post Cards and Stuffers, Handbook on Cartridge Sales and Service, Professional Phono Service Sign, Window and Wall Streamers, Service Tags, etc. With these sales tools you can easily turn that \$4.00 into HUNDREDS.

The E-V Basic 6 Preferred Type Cartridges enable you to make over 92% of all cartridge replacements and give immediate replacement service. Not only that... every E-V Cartridge now comes like a jewel in a new golden yellow, self-stacking plastic box.

It's the most powerful, most effective merchandising plan ever conceived in the phono service field!



Look for the Golden Yellow Cartridge Box

FREE

Send Now for Bulletin CP-1. Gives You the E-V Plan—Tells you How to Make \$4.00 Open New Business for You.

ELECTRO-VOICE, INC.
421 CARROLL STREET
BUCHANAN, MICHIGAN

Please Rush FREE Bulletin CP-1

Electro-Voice

421 CARROLL STREET • BUCHANAN, MICHIGAN
Export: 13 East 40th St., New York 16, U.S.A. Cables: Arlab
PHONO CARTRIDGES • MICROPHONES • HI-FI SPEAKERS • TV PRODUCTS

NAME _____
ADDRESS _____
CITY _____ ZONE _____ STATE _____

MY DISTRIBUTOR'S NAME _____

the bottom won't drop out!

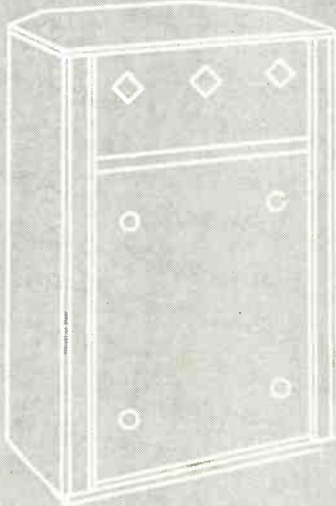

The bass response— weakest feature in most fine sound systems— is custom engineered into Jensen Back-Loading Folded Horn cabinets.

In this universal design, a long folded flare path, expanding on the Hypex* formula, gives superior bass response—even when placed on a sidewall. In a corner, walls act as extensions of the horn.

Available in mahogany and blonde for both 15" and 12" speakers.

Ask your jobber or write for 1020 brochure.

*Trade Mark Registered

Jensen

JENSEN MANUFACTURING COMPANY
DIVISION OF THE MUTER COMPANY
6601 S. LARAMIE AVE., CHICAGO 38, ILLINOIS
IN CANADA:
COPPER WIRE PRODUCTS, LTD., LICENSEE



reference or guidance for those who may desire this type of service. To provide satisfactory policing of the members of this association. To provide members of this association with the means of public expression. To provide the members of this association with a means of closer contact with each other and with all peoples of the electronic industry.

SAN DIEGO USES TV

The San Diego County (California) Electronic Association is using a series of spots on the local TV outlet KFMB-TV. Called "Symbols of Trust," the presentation has caused many housewives to ask TV technicians for their credentials when they arrive on neighborhood repair calls.

The Association has embarked on the first step of a plan for a program of contributions of their time and talent to worthwhile organizations by presenting a television projector to the San Diego Children's Convalescent Hospital.

Regular technical meetings are expected to keep the members abreast of new developments in the field. One of the most recent, held June 25th, was addressed by Robert Jablonski of Hoffman Radio and Television Corporation, and by James G. Duncan, of KFMB-TV, San Diego.

MIAMI PROGRESSES

The latest monthly letter of the Radio & Television Technicians Guild of Florida shows great improvement over previous issues. Nicely printed on 12 pages of slick paper, it contains considerable advertising and boasts an advertising manager, Robert Martin.

It starts out with a full-page editorial on u.h.f., and contains a column of local news on the distributors and countermen, as well as a page of local news ("Association Notes"). We learn that heavy preparations for the annual picnic were being made at the time of writing, and that the last Blood Bank drive meeting was a great success, due in no small part to the efforts of C. R. Gunn. The magazine also welcomes Bernard Williams as circulation manager and Ed Stevens as official photographer.

TECHNICIAN ELECTROCUTED

Frank Freudinger of Chicago was killed by contact with the high-voltage system of a TV set on which he was working, reports TISA.

This death of a qualified technician, TISA points out, is a particular warning against the use of fix-it-yourself books by the public. If a man who knew exactly what he was doing could get himself killed, laymen who are not familiar with the dangers are exposed to far greater risk. "Pulling the plug" as advised by the books does not necessarily eliminate the danger. Capacitors have been known to retain a charge for six months. And no amount of plug pulling can eliminate the danger of an imploding picture tube.

TUBES Today's Best Buys

Top Quality at Terrific Savings
RTMA Guaranteed

1A7GT	\$.79	6B4	1.50	7G7	1.30
1B3	.85	6BA6	.55	7H7	.70
1L4	.60	6BC5	.56	7N7	.90
1L6	.60	6BE6	.49	7Q7	.89
1LN5	.95	6BF5	.65	7V7	.95
1N23B	3.50	6BF6	.70	7W7	1.25
1N34	.69	6BG6G	1.48	12A7E	.40
1R5	.60	6BH6	.75	12A7T	.80
1S4	.85	6BJ6	.65	12A7U	.55
1S5	.80	6BQ6	.94	12A7V	.75
1T4	.85	6C4	.60	12A7W	.95
1U4	.60	6CB6	.65	12AX7	.75
1U5	.50	6CD6G	1.93	12BA6	.48
1X2A	.85	6E5	1.05	12BA7	.80
2D21	1.40	6H6M	.70	12BE6	.55
2X2	.60	6J5M	.65	12J5GT	.50
3A4	.75	6J6	.73	12SA7GT	.70
3A5	1.25	6K6	.65	12SF5M	.65
3Q4	.55	6K7	.70	12SJ7	.60
3V4	.62	6L6GA	1.05	12SK7	.65
3S4	.80	6N7G	.95	12SQ7	.70
5U4G	.55	6S4	.51	12SN7GT	.75
5V4	.95	6S7M	.85	12SR7	.65
5Y3GT	.39	6SA7GT	.70	14B6	.95
5Z3	.85	6SC7	1.10	19T8	.86
6A7	1.00	6SH7	.65	25AV5	.95
6AB4	.65	6SJ7	.70	25L6GT	.60
6AB5/6N5	1.25	6SK7GT	.53	25W4	.80
6AC7	.85	6SL7GT	.65	35L6GT	.33
6AG5	.65	6SN7GT	.65	35W4	.47
6AG7	1.40	6SQ7GT	.65	35Z5GT	.49
6AH6	1.40	6T8	.86	41	.85
6AJ5	1.45	6V6GT	.60	50B5	.53
6AK5	.95	6W4GT	.49	50C5	.53
6AK6	1.20	6X4	.45	50L6GT	.53
6AL5	.54	6X5	.45	59	1.50
6AQ5	.65	6Y6	.85	75	.85
6AS5	.75	7AD7	1.25	89Y	.75
6AT6	.45	7C5	.70	9001	1.25
6AU6	.65	7C7	.85	9002	1.05
6AV6	.50	7E7	1.30	9003	1.25
6AX3GT	.85	7F7	.95	9006	.35

Minimum Order \$15.00

IMMEDIATE DELIVERY!

Write for quotations, many other types available. 20% Deposit with order, balance C.O.D. All tubes subject to prior sale. Prices subject to change without notice.

WRITE, WIRE, CALL—TODAY!

We Buy Anything in Electronics—large or small quantities!

Nat Adelman

168 Washington St. New York 6, N. Y.
Co. 7-6091

Prerequisite to

Natural Reproduction
of Music

THE **BROOK**

ALL TRIODE HIGH QUALITY
AUDIO AMPLIFIER

The BROOK will play at extremely low volume, yet retain full naturalness of tone; or, recreate in your home the full volume of a symphony, or dance band, clear and clean. You will hear and FEEL live music and voices.



Write for technical data, booklet
"Better Listening"
and name of local dealer. Dept. EI-2

BROOK ELECTRONICS, INC.
34 DeHART PLACE, ELIZABETH 2, N.J.

RADIO-ELECTRONICS

The TRIO ROTATOR

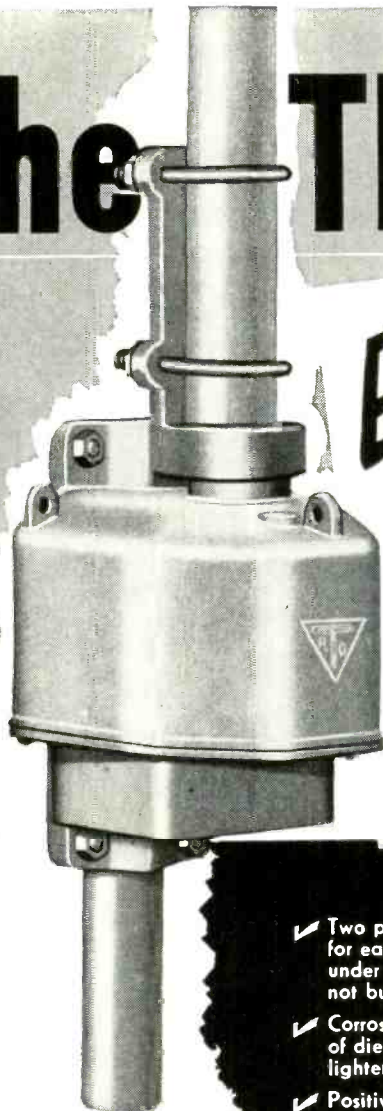

Easy to Sell!

It's easy to sell a product with as many plus features to talk about as the TRIO ROTATOR. In design, in construction, appearance; it is by far the outstanding TV antenna rotator in the market today!

Stays Sold!

In addition to providing a powerful sales story, the features listed below are your assurance of complete customer satisfaction: Assurance that the TRIO ROTATOR will give dependable performance year in and year out — in all kinds of weather!

- ✓ Two powerful 24 volt motors used — one for each direction of rotation. Each motor under load only fraction of time — will not burn out!
- ✓ Corrosion resisting, weatherproof housing of die-cast aluminum for greater strength, lighter weight, perfect alignment of parts!
- ✓ Positive electrical stops at ends of 360° rotation prevent damaging or twisting of leads!
- ✓ Will support heavy TV arrays — even in 80 MPH winds!
- ✓ Permanently lubricated with special grease that functions perfectly in high and low temperature extremes!
- ✓ Ball-bearing end thrusts on all shafts, including motor! Main shaft vertical load carried on large oversized "Oilite" self-lubricating bearing!
- ✓ All motors, shafts and gears mounted on a rugged, one-piece casting for true alignment and longer life!
- ✓ 11/16" diameter tool steel main shaft and mast holder will withstand 4500 inch pounds bending moment!
- ✓ Rotator and mast holder fits any pipe size up to 2" OD!
- ✓ Precision built to extremely close tolerances!



Smartly Styled

DIRECTION INDICATOR

The TRIO Direction Indicator is housed in a sturdy plastic cabinet of graceful lines. It is a beautiful instrument that will blend harmoniously with any furniture style.

Utmost ease in selecting the desired antenna direction is provided by a new "finger tip" control that operates at a light touch and the easy-to-read dial face that clearly and instantly indicates the exact antenna position.



**FULLY TESTED
BEFORE
SHIPMENT**

Each TRIO ROTATOR is thoroughly factory tested to the equivalent of 3 months of constant operation. This, plus an additional torque test guarantees each unit to be perfect in every detail of assembly.

The TRIO ROTATOR's sound design and construction has been proven by three years of extensive field testing under every extreme of weather.

TRIO Manufacturing Company
GRIGGSVILLE, ILLINOIS

TV SERVICING

is easier than you think

How many times have you asked yourself this question: "What can I do to make my servicing job easier?" Chances are you ask it every time you get a "stickler" in the shop. But have you ever stopped to consider that *all* your servicing . . . from the real headaches to the simplest repair . . . can be easier than you ever thought possible if you GET THE COMPLETE SERVICING INFORMATION ON A RECEIVER BEFORE YOU START TO REPAIR IT. Let's take a closer look to see why. *All* servicing data must originally come from the receiver manufacturer. He made the product, so he knows all about it. His information is not based on a single receiver but on hundreds, which are sampled. If you are using this kind of information, servicing is easy; but if you are using abridged data — information which does not originate with the set manufacturer — you do *not* have all the data required to do easy — permanent — prestige-building servicing.

Here's a typical example: For Stewart-Warner model 9122-A the set manufacturer prepared the equivalent of 35 pages (8½ x 11") of servicing data. The complete data is published in Rider TV Manuals Vol. 8 and in Rider TV Tek-File pack 12. The reason was that the production runs covered seven different codings (from A to G) plus 16 important changes in the receivers. Some of these changes were made to eliminate such actions as component resonance in the I-F system . . . horizontal sync instability . . . and the possibility of arcing in the high voltage system. Other changes were in tubes and parts. But *all* of the changes are vitally important to you when you're faced with a repair on this Stewart-Warner model. This is only one case in thousands of why it is absolutely necessary for you to have the complete, official, manufacturer-prepared servicing information for every set you repair.

There are two ways for you to get complete, official, factory prepared servicing information. One way is to write the set manufacturer directly. However, this takes time when you

need it most: While the customer's set is in the shop. So the easy way is to buy this data in complete published form. This means Rider Servicing Data! For 22 years Rider Servicing information has been the only publishing source for factory authorized and prepared servicing information: Exactly as issued by the manufacturer who made the set . . . organized into indexed, easy-to-follow style. In Rider Servicing Data you get all of the manufacturer's troubleshooting test patterns . . . schematics of all his productions . . . stage by stage alignment curves . . . clear, enlarged chassis views . . . the manufacturer's circuit changes . . . circuit explanations . . . voltage data, disassembly information and much, much more. For example: Rider Servicing Data has shown scope waveforms in TV receivers ever since the first TV receiver was made!

And Rider Servicing Data now has these important new features: manufacturers' trouble cures and guaranteed replacement parts listings. The manufacturers' trouble cures are standard (3 x 5") index cards, called Rider Handies, containing vital manufacturer-issued permanent trouble cures plus production changes. Each Handy is identified with a manufacturer and receiver model. With Rider Handies you save countless hours of diagnosis and repair time . . . because Handies contain the data you *must* have to make permanent repairs on many receivers. The replacement parts listings are included in the latest Rider Servicing Data. All these replacement parts must meet the physical and electrical performance ratings of the original equipment.

To meet your individual requirements, Rider TV Servicing Data comes in two forms. The Manual form; volumes covering the complete data on receivers manufactured during a certain period, and Tek-File form; separate packs containing complete data for specific models.

The TV Manual form has nine volumes covering more than 4,200 models of television receivers. Each vol-

ume has over 2,000 (8½ x 11") pages of servicing data with an index covering the contents of all volumes. Each volume is attractively bound in a permanent hard cover. The Manual form is ideal for shop use and as a permanent reference.

The Tek-File form now covers more than 2,200 models. Each Tek-File pack contains complete data for several of the most popular models . . . the ones you are called to work on every day. (Contents are clearly marked on the cover of each pack.) These models are bound in handy, standard file folders for easy home and shop use. In each Tek-File pack you get a special coupon. 15 of these coupons plus a small handling charge entitles you to a permanent, hard-cover manual binder for Tek-File shelf use. Or if you prefer, each coupon is worth five cents toward the purchase of any Rider book. Note: Get your free Tek-File indexes covering the contents of all packs at your jobber's. If he doesn't have them, write us.

For the complete servicing facts on *radio*, get Rider Radio Manuals. In 22 volumes Rider Radio Manuals give you the complete, factory-authorized, official AM, FM radio servicing data for receivers manufactured over the past 22 years! Plus complete data on auto radios, record changers, tuners and recorders. Everything is organized and indexed to make radio servicing easy.

DON'T BE SWITCHED

Remember, Rider Manuals and Tek-Files are the *only* source for complete published servicing data. If your jobber doesn't have them, **DON'T BE SWITCHED!** If he doesn't have Rider Manuals, write to us . . . we'll tell you where to get them. If he doesn't have Rider Tek-Files, write to us . . . we'll fill your order directly. (Please include your jobber's name.) Why not prove to yourself that Rider Servicing Data really makes servicing easy. Try one Rider TV Tek-File pack *at our risk!* Try a pack for the next receiver you repair . . . if you don't agree that it makes your servicing easier than anything you've ever used **RETURN THE PACK TO US WITHIN SEVEN DAYS AND WE'LL SEND YOU A FULL REFUND!** So act now . . . you have absolutely nothing to lose! John F. Rider, Publisher, Inc., 480 Canal Street, New York 13, N. Y. West Coast Office: 4216-20 W. Jefferson Blvd., Los Angeles, California.

With the Technician

TISA EXPELS

The following special bulletin was received from the Television Installation Service Association of Chicago:

Please be advised that Central Television Service has been expelled by this association by unanimous vote at the regular TISA meeting of July 2, 1952.

Henceforth, they are to be accorded none of the privileges of membership. A report on the same meeting warns members against "gimmicks" and "gimmick advertising" and instructs all members to clear their ads with the Executive Board, to the end that plans and devices that reflect unfavorably on TV or the TV service industry may be eliminated.

JOINT PENNSYLVANIA OUTING

The Lackawanna (Pennsylvania) Radio Technicians Association played host to the State organization and the National Electronic Technicians and Service Dealers Association (NETSDA) on July 20th, with a joint meeting and clambake at Lilly Lake. A number of matters vitally affecting the welfare of electronic technicians was brought up for discussion, and important decisions were reached on action to protect the interests of the membership.

TV TECHS QUIT MEETING

Protesting an "unneutral" attitude on the question of licensing, about 50 service technicians and officials of radio and TV repair concerns walked out of a Washington, D. C., meeting sponsored by a local distributor. The meeting, according to Norman Selinger, secretary of the local TV technicians' organization, was supposed to present "strictly neutral views on the issue of licensing radio and TV service technicians." After the first speaker, the admittedly anti-licensing Louis B. Calamaras of the National Electronic Distributors Association, had presented the case against licensing, local technicians asked for an opportunity to present the views of pro-licensing technicians in rebuttal. When this was denied or delayed, the pro-licensing technicians left the meeting.

Besides Mr. Calamaras, the meeting was addressed by John F. Rider and by Frank Mansfield, research expert of Sylvania Electric Products, Inc.

—end—

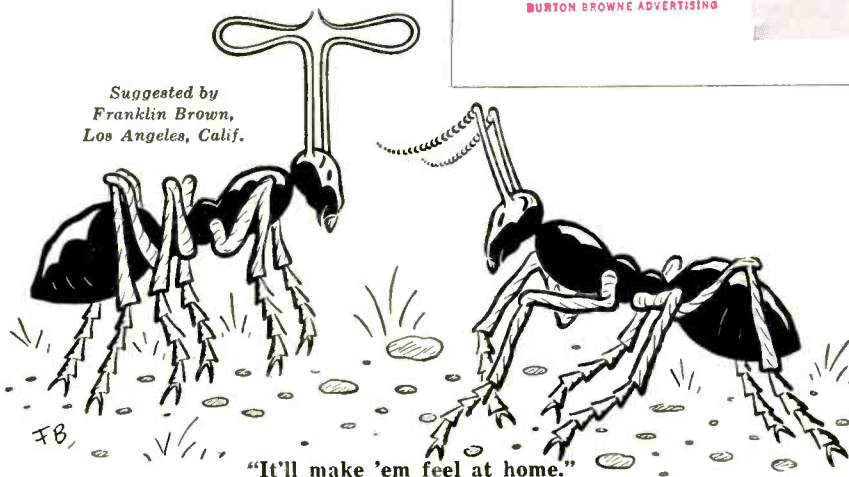

Suggested by
Franklin Brown,
Los Angeles, Calif.

"It'll make 'em feel at home."

SEPTEMBER, 1952

Simpson

perfectly designed
for proper servicing
of all tv and fm
receivers

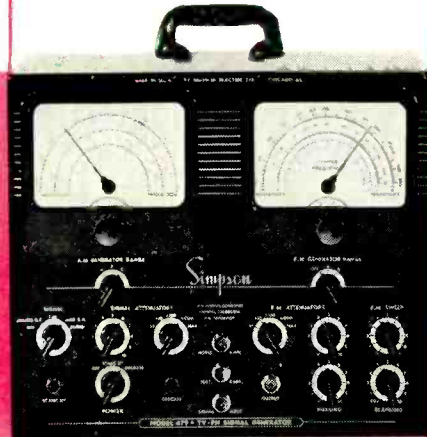

model 479
tv-fm
signal generator
\$269 dealer's net

Simpson

SIMPSON ELECTRIC COMPANY, 5200 W. KINZIE ST., CHICAGO 44, ILLINOIS 1-4221

BURTON BROWNE ADVERTISING

EASY TO LEARN CODE

It is easy to learn or increase speed with an Instructograph Code Teacher. Affords the quickest and most practical method yet developed. For beginners or advanced students. Available tapes for beginner's alphabet to typical messages on all subjects. Speed range 5 to 40 WPM. Always ready—no QRM.

ENDORSED BY THOUSANDS!

The Instructograph Code Teacher literally takes the place of an operator-instructor and enables anyone to learn and master code without further assistance. Thousands of successful operators have "acquired the code" with the Instructograph System. Write today for convenient rental and purchase plans.



INSTRUCTOGRAPH COMPANY

4701 Sheridan Rd., Dept. RC, Chicago 40, Ill.

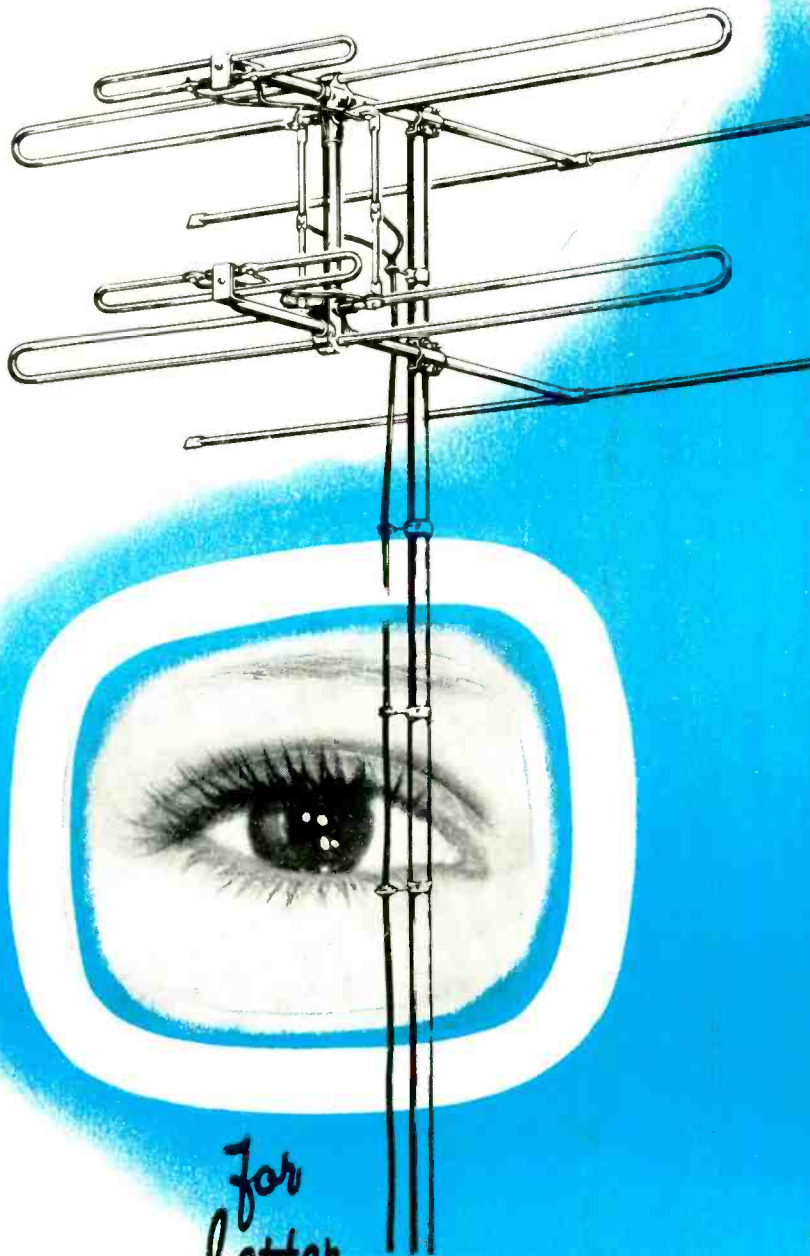

For
better
TV
Picture
Quality...

AMPHENOL **— IN LINE** **ANTENNA**

New Devices

MOBILE ANTENNA

Brach Manufacturing Corp., 200 Central Ave., Newark, N. J., announces a new high-frequency antenna (No. 475), covering 152 mc to 162 mc, for automobile communications systems.

The antenna is designed for roof-top mounting, with a locking device which bites into the metal roof, making it unnecessary to scrape the mounting surfaces to establish a ground connection.

The antenna portion is made of beryllium copper and is pressure-fitted into a locking nut. The model 476 shown in



the photo is a side-mount adaptation of the 475.

FIVE-INCH OSCILLOSCOPE

Hickok Electrical Instrument Co., 10514 Dupont Ave., Cleveland 8, Ohio, has released the new model 670 5-inch oscilloscope for visual alignment of AM, FM, and TV receivers when used with a sweep generator. The vertical-amplifier input impedance is 2.2 megohms shunted by 30 μ f; deflection sensitivity is .01 volt r.m.s. per inch. Pulse rise time is 0.6 μ sec. The horizontal amplifier has a sensitivity of .07 volt r.m.s. per inch, input impedance of 1 megohm shunted by 35 μ f, response from d.c. to 250 kc, pulse rise time 1.2 μ sec.

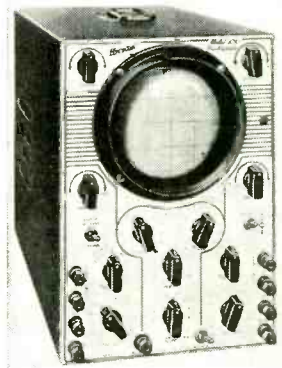

When the signal is applied directly to the deflection plates, vertical and horizontal sensitivities are 12 and 13 volts r.m.s. per inch respectively, and input impedances are 3.3 megohms.

The sweep oscillator is variable from 3 to 50,000 cycles with fixed sweep frequencies at 30 and 7,875 cycles. The 670 features controls for selecting negative or positive sync, horizontal sweep reversal, reversal of vertical deflection, Z-axis modulation, and a built-in detector for viewing modulation on r.f. signals.

The scope consumes 65 watts from a 117-volt, 60-cycle a.c. line, weighs 28 pounds, and is housed in a cabinet 9 1/4 inches wide, 12 1/4 inches high, and 18 inches deep.

NEW TV ACCESSORIES

Radio Merchandise Sales, Inc., 1165 Southern Blvd., New York 59, N. Y., announces the development of four new accessories for television installation: a thermal switch, 2-set coupler, local-distance switch, and a 4-channel switch.

The model TH-SW thermal switch, permits automatic operation of lamps, rotor, booster, and similar devices through the TV receiver. The model 4CS channel switch will switch four antennas into one receiver, or will operate any one of four receivers from a single antenna. The unit is engineered to reduce the coupling effect between the antenna in use and those which are idle.

The local-distance switch eliminates the overload which causes either a

RADIO-ELECTRONICS

PHILCO

Test Equipment for Measurements you can rely on



GET it right the *first* time with precision-built Philco Test Equipment. Save time, avoid guessing, build your reputation for dependable, thorough service work. Choose Philco instruments, tested and approved in the famous Philco Engineering Laboratories, for reliable performance and long-life accuracy.

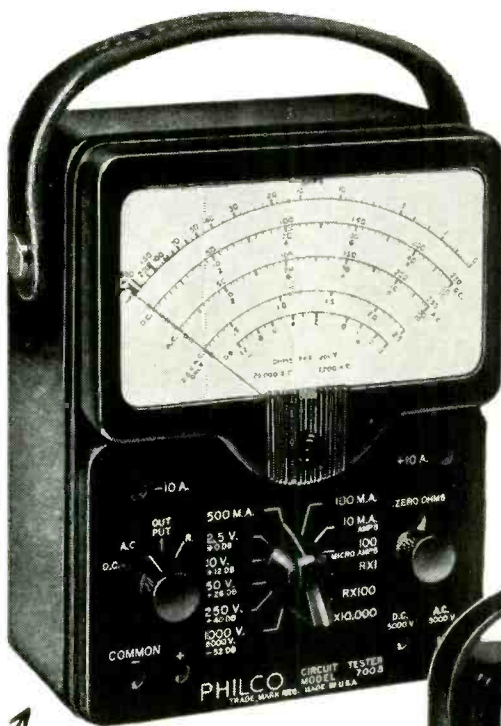

Philco Circuit Tester

Model 7005 Dimensions—5 $\frac{1}{4}$ " wide x 7 $\frac{1}{8}$ " deep x 3 $\frac{1}{2}$ " high.

Battery—Dry cell—"A" size.

Voltage Ranges DC—(20,000 ohms per volt) 2.5, 10, 50, 250, 1000, 5000 Volts.

Voltage Ranges AC—(1000 ohms per volt) 2.5, 10, 50, 250, 1000, 5000 Volts.

A.F. Output—2.5, 10, 50, 250, 1000.

Volume Level— -12 to +55 db (5 steps).

Resistance—RX1—12 ohms center—2000 Full Scale. RX100—1200 ohms center—200,000 Full Scale. RX10,000—120,000 ohms center—20 Megs. Full Scale.

Current—100 Microamperes; 10, 100, 500 Milliamperes; 10 Amperes.

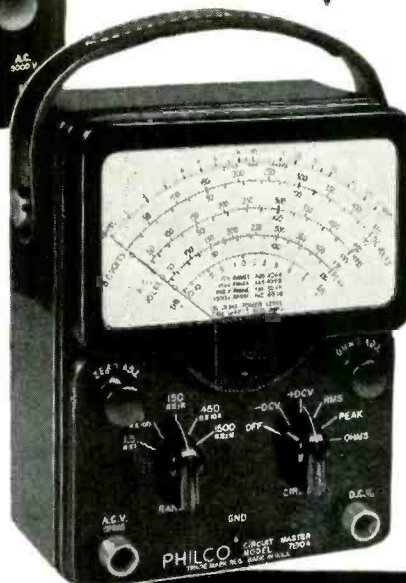

Philco Circuit Master

Model 7004 Dimensions—5 $\frac{1}{8}$ " wide x 7 $\frac{1}{8}$ " deep x 3 $\frac{1}{2}$ " high.

Operating Voltage—105-125 Volts; 60 cycles.

Basic Circuit—Balanced difference amplifier. Miniature double triode.

Voltage Ranges (DC)—1.5, 15, 150, 450, 1500 Volts.

Voltage Ranges (AC)—1.5, 15, 150, 450, 1500 Volts. 1.5, 15, 150 Volts. AC—RMS and peak—compensated to same frequency response.

Circuit Switch Positions—Off + DC Volts, —DC Volts, RMS Volts, Peak Volts, Ohms.

Ohms Ranges—Full scale, 100 times center. RX1—10 ohm center, RX100—100 ohm center. RX1000—10,000 ohm center. RX10,000—100,000 ohm center. RX1 Meg.—10 Megohm center.

Decibels— -20 to +65 on AC Peak. Reference level 1 Milliwatt, 600 ohms—zero level.

Internal Resistance—AC Volts (RMS and Peak), 5 Megohms. DC Volts, 10 Megohms.

External Adjustments—Zero adjust and ohms adjust.

For Information and Prices—Call Your
PHILCO DISTRIBUTOR

buzz in sound, or darkening of the picture in strong-signal areas. The switch, model LDS, is inserted in the antenna circuit. When overload occurs, the switch is moved to LOCAL position. This attenuates the signal and in turn eliminates the overload.

The AC-2 2-set coupler permits operation of two sets from a single antenna. It distributes the signal equally to both receivers, and there is



no limitation as to its location or length of lines between the coupler and either set.

NEW SWITCH KITS

The Centralab Division of Globe-Union, Inc., 900 E. Keefe Ave., Milwaukee 1, Wis., announces the availability of its newly-revised 414 and 419 switch kits, which consist of the latest

switch parts in a 17 x 11-15/16 x 12 3/4-inch metal cabinet. Kit 414 has 11 phenolic switch sections, 31 index assemblies, and complete hardware



consisting of knobs, brackets, tie rods, spacers and dial plates. Kit 419 contains 81 steatite-ceramic switch sections, 27 index assemblies, and complete hardware. Both switch kits are described in detail in bulletin 42-138 available from the manufacturer.

CAPACITOR NETWORK

Sangamo Electric Company, Marion, Ill., has announced development of the type BTN capacitive network, a multi-section, metal-encased, hermetically-sealed paper-dielectric unit. It provides a selection of capacitive Pi, Y,

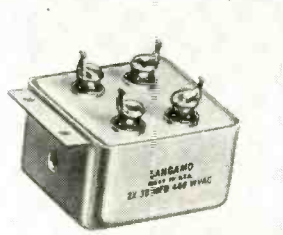

or Delta networks. Type BTN can be provided with mineral oil, pentachlorodiphenyl, or electrical-grade waxes as impregnants. Units are supplied in

ferrous or nonferrous cases. Complete data available from manufacturer.

PICKERING EQUALIZER

Pickering and Co., Inc., Oceanside, N. Y., is distributing the new 410 audio input system (equalizer-preamplifier) designed to serve as an audio control center. Three input channels are provided: two are for high-level audio signals and one for magnetic type pickups. The pickup channel provides 40 db gain at 1,000 cycles and 6 db per octave of bass boost below the low-frequency turnover. It is self-powered, operates from a 115-volt a.c. line. Three a.c. outlets on the rear of the chassis are controlled by the a.c. switch on the panel, permitting this unit to be used as a master control for other components of the system.



Its design features include:

1. An accurately equalized preamplifier for all magnetic pickups.
2. A 3-position record compensator which correctly matches the characteristics of popular types of recordings.
3. Step-type low-frequency control having 5 positions of bass boost.
4. Step-type high-frequency control having 4 positions of high-frequency rolloff and one position of high-frequency boost.
5. Minimum intermodulation and harmonic distortion.
6. Extremely low noise and hum level.
7. Compact in the vertical plane for easy mounting in any cabinet.
8. All electrical outlets and connections as well as the vacuum tubes are located on the rear of the chassis.
9. Cathode-follower output allows the main amplifier and speaker system to be located for best acoustic performance, at distances as great as 100 feet from the control center.

12-ELEMENT TV YAGI

The LaPointe Plascomold Corp., Rockville, Conn., announces its new Vee-D-X Long Long John 12-element, single-channel series of TV antennas. The antennas feature ruggedized construction with V-shaped boom braces and reinforced element stampings, full 6-mc bandwidth, and high front-to-back ratio.

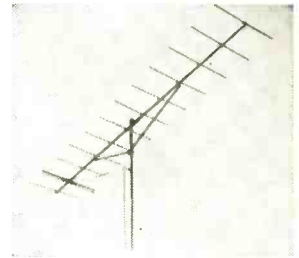

WATERTIGHT FUSE POSTS

Littelfuse, Inc., 1865 Miner St., Des Plaines, Ill., announces a new watertight fuse-extractor post for 3AG, 4AG, and 5AG fuses. Molded of black bakelite, leakage is prevented by inserting body contacts at the time of molding.

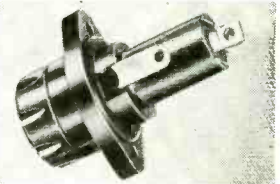

Rubber rings seal the front panel and the knob seats squarely in the shell. One-piece terminals and welded joints reduce voltage drop. Ease of extraction is insured by a leaf-spring grip on the fuse. There is no danger of shock while removing the fuse from the post by hand.

BUILD 15 RADIOS WITH THE PROGRESSIVE RADIO "EDU-KIT"

This is a practical home radio course! No radio experience is needed. You start learning a simple circuit and advance as quickly as you wish. You build RECEIVERS, TRANSMITTERS, AMPLIFIERS, CODE OSCILLATOR AND SIGNAL TRACER. All parts and instructions are included and clearly explained. Nothing extra to buy — you keep everything. You can quickly pay for this kit by repairing radios. The Signal Tracer alone is worth more than the small cost of this kit.



USED BY RADIO SCHOOLS AND GOVERNMENT AGENCIES!

The Progressive Radio "Edu-Kit" includes tubes, paper condensers, mica condensers, electrolytic condensers, variable condensers, selenium rectifiers, chassis, hardware, tie strips, tube sockets, solder, wire soldering iron, tubing, coils, instruction book, radio tester, etc.; in brief, everything you need in a practical radio course.

You risk nothing -- 10 DAY MONEY-BACK GUARANTEE

FREE RADIO TESTER AND SOLDERING IRON

Anyone Can
LEARN RADIO AT HOME
✓ NO PREVIOUS TRAINING NEEDED
✓ EXCELLENT BACKGROUND FOR T. V.

FREE

Radio & T.V. Troubleshooting Guide sent when you ask for complete information OR rush us your order and you get FREE Code Oscillator Key (value \$2.95) in addition to Radio & T.V. Troubleshooting Guide. Write today!

POSTAGE PREPAID ON CASH ORDERS — C.O.D. ORDERS ACCEPTED IN U.S.A.

BUILD 15 RADIOS
Only
\$19.95
COMPLETE

PROGRESSIVE ELECTRONICS CO.
497 UNION AVE. RE-63 BROOKLYN 11, NEW YORK

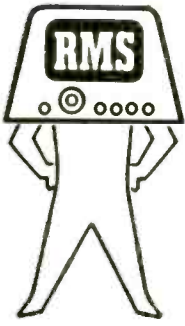

A properly selected **RMS** antenna helps you do...

THE BEST JOB IN YOUR AREA

HOW TO SELECT THE PROPER RMS ANTENNA FOR YOUR PARTICULAR INSTALLATION

• up to 25 miles — FA-1 OR YA-100

• up to 60 miles — FA-2, CVA-500, STY (5 element yagi)

• up to 85 miles — FA-4, CVA2-500

• over 85 miles — CVA4-500, STYL8—, STYL10—



REDI-RIG RMS Model FA-1

- Completely preassembled — no loose parts or hardware.
- Exceptionally flat response across entire tv band.
- 3/8" dowel-reinforced aluminum elements.
- Plus six other distinctive mechanical and structural advantages!

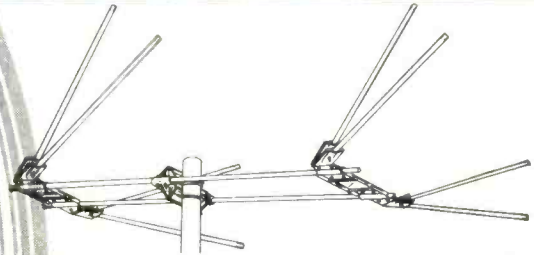

FRINGELEADER END-FIRED ARRAY RMS Model CVA-500

- Completely preassembled.
- High gain on all channels.
- 3/8" dowel-reinforced aluminum elements with unique double U-bolt attachment to the mast.



SUPER STEEL-BRACED YAGIS RMS Model STYL8-

- Cut for specific channel — one of the highest gain antennas in use today.
- Steel brace assures permanent orientation.
- Deluxe construction and engineering features — the fastest installing long boom yagi on the market!

SEE YOUR
RMS JOBBER

RMS



2016 BRONXDALE AVENUE • NEW YORK 60, N. Y.



Announcing Radio Receptor's new range of Germanium Diodes



Germanium Diodes

FEATURING POLARITY AT A GLANCE!

Keynoting sound design features and simplicity in construction, the new Radio Receptor Germanium Diodes will give a maximum of trouble-free operation even under the most adverse conditions.

Normally in diodes such as these, one side of the germanium wafer is plated so that it may be soldered to the base . . . but Radio Receptor's improved production methods make it possible to omit plating, thus eliminating possible flaking and improving quality.

The distinctive tapered shape of the glass-filled phenolic cartridge body indicates the direction of current flow, while the hexagon form assures ease of handling—prevents rolling, especially when the leads are cut off to permit mounting the diode in clips.

Submit your germanium diode application problems to us. . . We'll be glad to make recommendations without obligation!

Germanium Transistors are coming!

... WATCH FOR OUR ANNOUNCEMENT SOON



current flow
ACTUAL SIZE

RADIO RECEPTOR COMPANY, Inc.

SELETRON & GERMANIUM DIVISION



Since 1922 in Radio and Electronics



Sales Department: 251 West 19th St. • New York 11

Our Lowest Price Ever For this Great New 1952 Model 630-DX CHASSIS

FREE Channel Strips for UHF in locales where UHF is transmitted this year!

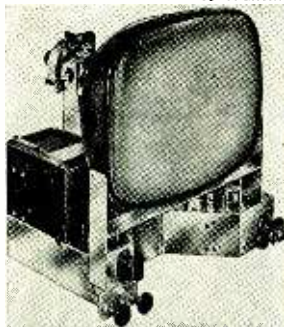

ADVANCED DESIGN INCLUDES NEW CASCODE TUNER—30 TUBES—FOR 16" to 24" PICTURE TUBE

Save Many Dollars for this. The Finest Chassis Available At Any Price. For long range and best reception up to 200 miles without a booster, this new, advanced 630-DX Chassis gives 3-times normal reception. Special extra-high-gain standard coil tuner gives greater sensitivity, top performance on any channel; aligned & tested for 5 hours; molded condensers; 4 microvolts sensitivity; FM sound system; horizontal & linear lock and is directly adaptable for color and UHF. Don't wait for color or UHF—Buy now and use this same chassis.

\$139.50 (incl. Fed. Tax, less CRT) Can't be beat for Quality—Can't be beat for Price! RMA Guaranteed—Factory Wired, ready to play. Complete with 12" speaker, hardware and knobs.

UNIVERSAL MOUNTING BRACKETS \$5.95
FREE: New Trouble Shooting book with every chassis!

New Reduced Prices TV PICTURE TUBES

Full Year Guarantee—Non-glare—Black Face—Brand New—Standard Brands—Sealed Cartons

10BP4 Round Glass \$19.95	16KP4 Rect. Glass \$24.95
12LP4 Round Glass 22.95	17BP4 Rect. Glass 23.95
14BP4 Rect. Glass 23.95	19AP4 Round Metal 33.95
16AP4 Round Metal 36.95	20CP4 Rect. Glass 34.95
16GP4 Round Metal 28.95	21EP4 Rect. Cyl. face 36.95
16HP4 Round Glass 32.95	24AP4 Round Metal 63.95

Never Before have we been able to sell these tubes at such low prices—order now while supply lasts!

Table model cabinets for these chassis, Model 100: Original list: \$79.95. Now! \$38.50

Model 200 Console: Original list: \$99.95. Now! \$45.50
Blonde finish. Add \$10.
300 OHM LEAD-IN Heavy duty—Best quality
100 ft. hank. \$1.95
1,000 ft. spool. \$17.95

NOW: Write for FREE Catalog including new complete line of tubes, parts, accessories for radio & TV, plus test instruments.

MINIMUM ORDER: \$5.00. 25% deposit with order, balance C.O.D. Include postage with order. All merchandise subject to prior sale. F.O.B. New York City. Prices subject to change without notice.

The ROSE Company

100 Park Place, Dept. E-9, New York 7, N. Y., COrtlandt 7-6195

EQUALIZER PREAMP

The Radio Craftsmen, Inc., 4401 N. Ravenswood Ave., Chicago 40, Ill., have added the model 300 equalizer-preamplifier to their line of high-fidelity audio equipment. The unit is designed to control the response of an amplifier when fed from a tuner, microphone, or phonograph pickup.

The unit has five main controls: a selector switch with positions for standard and LP pickups, microphone, and three high-level inputs. (Input impedance of the high-level channels is 500,000 ohms, and 1 megohm for the microphone channel. The impedance of the phono channel is matched to the cartridge.) Separate bass and treble controls are continuously variable to provide up to 16-db boost or attenuation. The power on-off switch controls the built-in power supply and associated units which may be plugged into the power receptacle at the rear. It has a volume-compensated loudness



control. Secondary controls are: Low-frequency equalization lever with turn-over positions marked LP, 300, and 500 cycles. High-frequency equalization lever which provides droops of minus 4, 8, 12, and 16 db at approximately 10,000 cycles. Low-range lever with five filter positions for reducing hum and motor rumble. High-range lever with five positions for reducing hiss and record scratch. Loudness-volume lever which allows the use of a conventional volume control without loudness compensation.

The unit uses one 12AV6 and four 12AX7's in a circuit which includes a dual-triode phono preamplifier with selective feedback for equalization, two cathode-follower-driven grounded-grid amplifiers for tone compensation, and two cathode followers for input and output of the common high-level channel. Maximum gain is 26 db in the high-level channel and 58 db for phono and microphone.

PAPER CAPACITORS

Pyramid Electric Co., 1445 Hudson Blvd., North Bergen, N. J., is producing a new type of molded tubular paper capacitor. *Imps*, as the new units are called, are molded of thermo-setting plastic which resists moisture and operates at temperatures ranging from -40° C. to +100° C.



Each section is noninductively wound, and is available in capacitance values ranging from .00025 to 0.5 µf in 200- and 400-volt ratings, and from .00025 to 0.25 µf in 600-volt ratings. Complete data is available on your own letter-head request from the manufacturer.

ALL-CHANNEL ANTENNA

The Gonset Co., 801 So. Main St., Burbank, Calif., is producing an all-channel v.h.f. antenna, the Gonset Rocket, which functions as a resonant unterminated rhombic antenna on the high channels and a folded dipole with reflector on the low channels. By making



All specifications given on these pages are from manufacturers' data.

the legs three quarter-wavelengths long on the high channels, a good front-to-back ratio is obtained without a terminating resistor. The company claims the impedance match to 300 ohms is better than if a terminating resistor were employed.

On the low channels the functioning and performance are comparable to those of a conventional folded dipole. Gain and front-to-back ratio on the low channels are improved by a parasitic reflector. The antenna is assembled to speed installation time and prevent the loss of loose hardware. For fringe-area applications where more gain is needed, two- and four-bay stacking harnesses are available as extras.

TV WALL-THRU

Mosley Electronics, 2125 Lackland Rd., Overland 14, Mo., announced a new weatherproof TV or FM lead-in wall entrance that can be installed in any wall up to 13 inches thick. The Mosley Wall-Thru unit consists of precision-molded polystyrene inside and outside wall plates combined with a 14-inch extruded polystyrene tube, 3/4 of an inch outside diameter. Both wall plates accommodate either standard flat 300-ohm transmission line or RG-59/U coaxial cable and are readily adopted for use with tubular type 300-ohm line.

A universal TV lead-in socket may be mounted directly on the inside plate if desired, providing a solderless low-



loss plug-in connection of TV set to lead-in when used with a matching transmission line plug. The Wall-Thru is available separately or may be purchased complete with socket and mating plug.

TEST LEADS

Insuline Corp. of America, 36-02 35th Ave., Long Island City, N. Y., an-

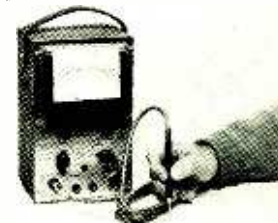

nounces two new test leads designed to fit the RCA vacuum-tube voltmeter and others equipped with screw-on microphone type connectors. The No. 316 contains an isolating resistor in its probe and is intended for d.c. measurements; the No. 317 is a straight-through lead for utility applications. Each is 6 feet long, made of heavy, shielded wire. Handles are insulated.

YAGI ANTENNA

Channel Master Corp., Ellenville, N. Y., enters the low-priced Yagi field with



its Challenger 5-element Yagi antenna, series 550. Over 7 db gain is claimed on the single bay which matches 300-ohm line, and has a 5-1 front-to-back ratio. Noise interference is minimized. A transformer-type folded dipole made in one single assembly is built into the antenna. The director and reflectors, made of reinforced aluminum, are completely preassembled, and the 1-inch cross-arm has plugged ends.

—end—

New Patents

IMPROVED PHOTOMULTIPLIER

Patent No. 2,594,703

Louis F. Wouters, Oakland, Calif.

(Assigned to United States of America as represented by the U. S. Atomic Energy Commission)

This invention greatly increases the amplification of a photomultiplier tube by working the tube at higher-than-normal voltages. Power is applied intermittently so the tube does not overload. Although the peak voltages are high, the average power input is kept below the maximum limit.

The photomultiplier is shown as V1. It may be type 931-A which has a cathode, 9 dynodes (secondary-emission electrodes), and an anode. With constant input, the maximum limit for the tube is less than 1,250 volts. With this circuit we can use as much as 2,000 volts. It is applied through capacitor C.

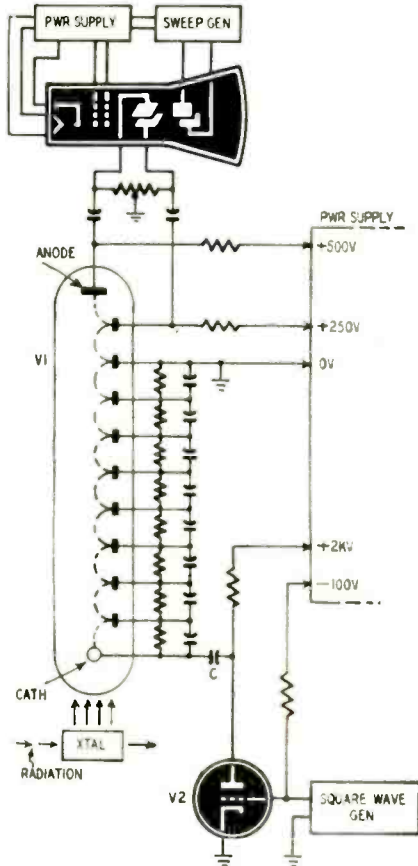

V2 is a triode pulsed by a square-wave generator which alternately blocks and unblocks the tube. When V2 is cut off, C charges to 2,000 volts. At completion of the charge, no current can flow through the V1 voltage divider. Therefore the cathode of this tube has the same potential as the other elements and the tube does not operate. With V2 conducting, one end of C is effectively grounded. Thus the capacitor voltage (2,000 volts) is placed across V1. Each dynode now receives about 250 volts more than the preceding dynode. The phototube operates at high efficiency. The tube cannot overheat, however, since V2 blocks again and removes the input from V1.

The figure shows a typical application for this circuit. A scintillation crystal is shown receiving radiation. The light flashes are converted to electron-emission pulses by the photocathode. While V2 is cut off these electrons return to the cathode. When a positive square wave from the generator overcomes the cutoff bias, V2 conducts and grounds the positive end of C. Electrons from the photocathode are drawn to dynode 1 and displace a large number of secondary electrons. These, in turn, are attracted to dynode 2, where they displace approximately double their own number. Current multiplication at each dynode is proportional to the applied voltage.

The greatly-amplified output signal between the last (ninth) dynode and the photomultiplier anode is applied across the vertical deflecting plates of a cathode-ray oscilloscope.

Harry M. Neben,

chief of Amphenol's Electrical Testing Laboratory

recommends

model 303 Vacuum Tube Volt-Ohmmeter

Simpson



SEE YOUR DEALER'S LIST
 SIMPSON ELECTRIC COMPANY
 636 W. KINZIE ST.
 CHICAGO 44
 CO. BUSBUS 1-123

SEE SIMPSON BROWNE ADVERTISING

RADIOS
1, 2 & 3 band Electric and/or Battery

TELEVISION
AC/DC Operation

TEST INSTRUMENTS
Write for FREE Catalog

ARKAY—Radio Kits, Inc.
120 Cedar St., New York 6, N. Y.

WANTED

STEVENS COILWINDER (OR SIMILAR)
 UNIVERSAL TYPE for R.F. coils. Also Boonton or Marconi "Q" Meter. Advise age, model number and condition.

WALTER L. SCHOTT CO.
 3225 Exposition Place, Los Angeles 18, California

PEN-OSCIL-LITE

Extremely convenient test oscillator for all radio servicing; alignment • Small as a pen • Self powered • Range from 7Mc cycles audio to over 600 megacycles u.h.f. • Output from zero to 125 v. • Low in cost • Used by Signal Corps

GENERAL TEST EQUIPMENT
 38 Argyle Ave. Buffalo 9, N. Y.

Another Outstanding Jobber

HIGGINS & SHEER
 6 Baymead Avenue
 Poughkeepsie, New York

TEICO has all 17 KITS
 & INSTRUMENTS
 in stock!

See E.C.C. ad on Page 28



TAKES THE "PORTERING" OUT OF PORTABLE RECORDING



THE *Magnemite**

**Battery-Operated Spring-Motor
PORTABLE TAPE RECORDER**

Field recording can now be made with as little effort as studio or home recording. Light and compact, the tiny Magnemite is the first completely portable tape recorder! Earphone monitoring and playback facilities built in. Powered by self-contained dry flashlight batteries that last 100 operating hours. Four models are available for any speech or music recording requirement, including a model designed to NAB recording standards.

**Model
610-B**
Size: 11½ x 8½ x 5½ in.
•
Weight, including batteries: 10 lbs.
•
Net Price: \$225

*Trade Mark Reg.

Write for complete literature, specifications and direct factory prices

AMPLIFIER CORP. of AMERICA • 398-2 Broadway • New York 13, N.Y.

NEW! MOSLEY WALL-THRU

For TV, FM and Amateur Transmission Line

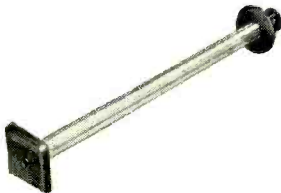

- Fits Any Wall Up To 13" Thick!
- Completely Weather-Proof!
- For Standard Flat 300 Ohm Line or RG-59/U Co-ax Cable!
- MOSLEY Lead-In Socket Can Be Mounted Direct To Inside Plate!
- Precision Molded Polystyrene End Plates!
- Easily, Quickly Installed!

Cat. No. 625
List Price \$1.95

Cat. No. 625-PK WALL-THRU, complete with MOSLEY Universal TV Lead-In Socket and Plug.
List Price \$3.00

MOSLEY ELECTRONICS

2125 Lackland Road Overland, Missouri

REDUCING FACSIMILE DISTORTION

Patent No. 2,587,617
Frank A. Hester, New York, N. Y.
(Assigned to Faximile, Inc.)

This circuit reduces distortion in facsimile signals. Much of the distortion is determined by the scanning aperture area. A small aperture means more lines per inch and relatively low distortion. Unfortunately, it also increases scanning time and requires greater bandwidth, so compromise is necessary.

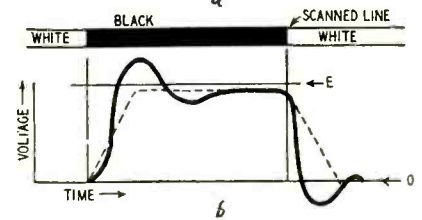
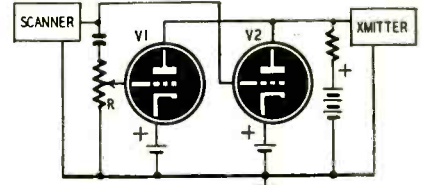

This new circuit is especially effective when transmitted images are contrasty (like black-and-white printed matter). When a scanned image changes abruptly from white to black, or vice versa, the corresponding voltage output should be a perfect square wave. This is impossible with an aperture of finite area. The actual voltage rises gradually from zero to maximum when the image goes suddenly from white to black. The voltage drops gradually to zero when the image goes from black to white.

The new basic circuit is shown at *a* in the figure. The normal facsimile signal feeds V2 directly. Differentiated output feeds V1 as shown. In *b* the dotted line shows how the V2 signal varies as the aperture scans first white, then black, then white again. The differentiated V1 signal provides a peak which overshoots in the positive direction during a voltage rise. The peak overshoots in the negative direction during a fall in voltage. (See full line in *b*.) R determines the steepness of voltage rise and fall.

The output is limited to a maximum value E and it cannot drop below zero. Therefore the overshoots do not appear in the output. However, the combined output from V1 and V2 does approximate a square wave.



Regency

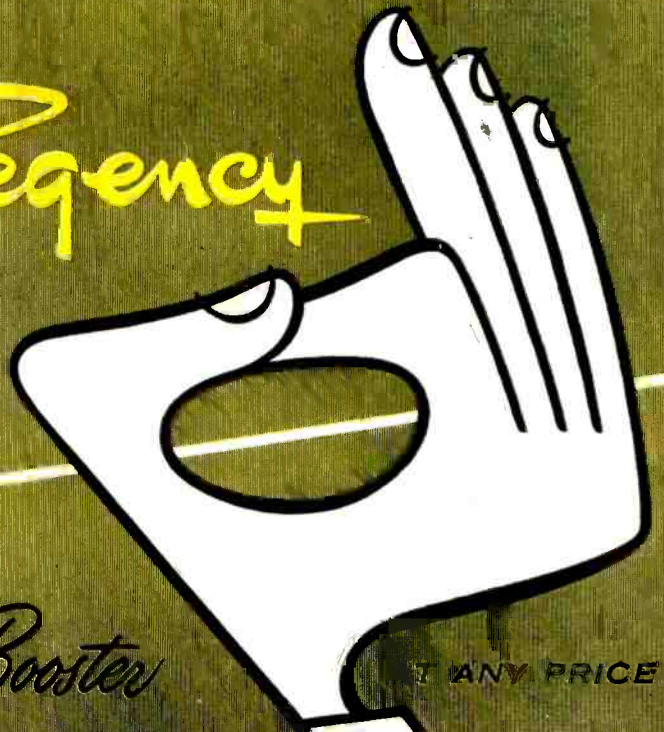

Largest Selling Booster

AT ANY PRICE

TIMING CIRCUIT

Patent No. 2,590,302

Clarence T. Evans, Wauwatosa, Wis.
(Assigned to Cutler-Hammer, Inc.)

This timer is suitable for use with electrolytic capacitors. Operated from the a.c. line, it is both efficient and reliable.

An E-shaped relay core is shown. The relay armature A1-A2 is pivoted on the center arm of the E. Because of its construction, one portion of the armature, either A1 or A2, touches the relay core and the other is pulled away. In the normal position shown here, A2 is attracted and A1 is pulled away, opening contacts K.

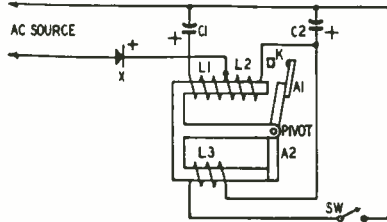

The center-tapped or "closing" coil L1-L2 tends to attract A1. The lower or "lockout" winding tends to attract A2. Each coil of the closing winding has more turns and greater magnetic force than the lockout coil L3.

When the timer is first connected to the line, rectified current flows through rectifier X into the center-tap. Equal currents flow in opposite directions through L1, L2, and charge electrolytic capacitors C1, C2. The armature remains in its normal position as shown because the electromagnetic fields of L1 and L2 buck each other. When the charge is complete, the current ceases.

The timing interval begins with closure of SW. C2 begins to discharge through L3. As the voltage across C2 drops, it permits current to flow through L2 and L3. The magnetic force due to L2 increases with time until it is sufficient to draw A1 to the core, and the contacts K are closed. This ends the timing interval.

THYRATRON VOLTMETER

Patent No. 2,591,511

Alfred Gordon Clarke, Slough, England
(Assigned to Ronald Trist & Co., Ltd.)

Here is a circuit we seldom see: a gas-tube voltmeter. A thyatron is often used as a switch, for "on" and "off" applications. This inventor uses one of the cold-cathode type to measure d.c. The thyatron is rugged and requires no filament supply. In this circuit, there is negligible drain from the source.

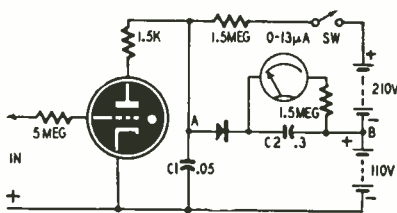

When SW is closed, the power supply charges C1. The capacitor voltage rises until the tube fires. Then C1 discharges through the tube. The voltage of the capacitor drops until it is too low (about 110 volts) to support conduction. After the tube is extinguished, C1 charges again. This cycle recurs about 6 times a second. The voltage at point A rises and falls periodically. The peak varies with grid bias. With zero input, the tube fires at slightly above 110 volts. With a bias of about 50 volts, the plate potential may have to go as high as 160 volts to fire the tube.

The voltage fluctuations between A and B are smoothed by filter capacitor C2. The average value is measured by a sensitive microammeter. The rectifier permits C2 to charge rapidly but prevents it from discharging except through the meter.

With zero input to this voltmeter, the potential at A will vary little from that at B. The meter will not deflect. With a large negative input, C1 can charge to a high voltage before the tube fires. This high peak at A will show up as a large meter deflection. The voltmeter can measure up to 50 volts.

The large grid resistor protects the tube and the signal source.

"CONICAL-V-BEAMS"

REGISTERED TRADE MARK

3 BIG REASONS WHY
telrex
is your logical ANTENNA CHOICE!



TELREX "FISHBONE" WITH TEN WORKING ELEMENTS GUARANTEED TO OUTPERFORM ANY YAGI ANTENNA! Recommended for superior reception in suburban and outlying areas, the "Fishbone" is constructed for lasting, trouble-free installations.

"BAT WING" the finest top-of-set antenna made REQUIRES NO TUNING, PRUNING OR ADJUSTMENTS! Outperforms any other indoor type and features modern, rich styling to harmonize with finest furnishings.

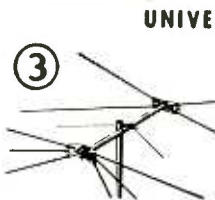

UNIVERSAL SERIES "CONICAL-V-BEAMS"

WITH HI-V-REFLECTOR AVAILABLE NOW CUSTOMIZED FOR YOUR OWN RECEPTION AREA! These famous-for-superior-performance antennas are supplied to your distributor custom-cut for best reception in your particular location.

NOW! THE DUAL-DRIVEN FISHBONE JR.

FOR ALL VHF CHANNELS — New six element TV series. Extremely high forward gain and front to back ratio exceeds most 8 element beams — compares favorably with many 10 element antennas. Supplied to distributors custom cut.

"CONICAL-V-BEAMS" are covered by Patent No. 23,346 CANADIAN and FOREIGN PATENTS PENDING

telrex INC.
CONICAL-V-BEAMS

AMERICA'S OUTSTANDING TELEVISION BEAM

Be sure it's a "CONICAL-V-BEAM" — look for the *telrex* TRADEMARK

ASBURY PARK 9, N. J.

So You Want To Be A Writer!

That idea you may have for writing a technical book is absolutely no good unless you do something about it. If you're dying to reveal all you know about TV; if you feel the world is wasted without your words on servicing, or if you nurture a secret ambition to out-theorize all the books on TV theory, then start your writing career by writing to us. Just send us a letter outlining your ideas. Our reply will contain a copy of our author's guide and details of royalty payments.

Book Dept.
RADCRAFT PUBLICATIONS, INC.

25 West Broadway
New York 7, N. Y.



FOR ELECTRONIC COMPONENTS

We offer immediate delivery from our vast stock of more than 25,000 items—all standard make, carefully inspected and fully guaranteed. Our prices are below market.

Always Check Wells' Stock First!

Quotations and quantities available will be given immediately upon request.

- ADEL CLAMPS
- ANTENNAS
- Insulators, Mast Sections
- BINDING POSTS
- BLOWERS
- CABLE ASSEMBLIES
- CHOKES
- COILS
- CONDENSERS
- Oil Filled, Bathub, Hearing Aid, Transmitting Micas, Silver Micas, Ceramic, Variable, Trimmer
- CRYSTALS
- DYNAMOTORS & BRUSHES
- FILTERS
- FUSES & MOUNTINGS
- GENERATORS
- GROUND RODS
- HEADSETS
- IF COILS
- JACKS
- JACK BOXES
- KEYS, Telegraph
- KNOBS
- LAMPS
- LORD MOUNTS
- LUGS
- MOTORS & BRUSHES
- PLUGS
- RECTIFIERS
- Selenium, Copper Oxide, Meter, Diode
- RESISTORS—All Types
- SELSYNS
- SOCKETS
- SWITCHES
- Aircraft, Micro, Switchettes, Toggle
- TIMERS
- TUBING—Flexible
- TUNING SHAFTS
- TRANSFORMERS—All Types
- VIBRATORS
- WALKIE TALKIES

Available Now!

A complete signal corps stock number listing of items in our stock. Write for listing No. SG-200. (For government agencies and contractors only.)

Manufacturers and distributors—write for Radio-Electronics Catalog No. H 501.

Write, Wire, Phone Your Requirements

all phones: **SEeley 8-4143**



833 W. CHICAGO AVE., DEPT. Y, CHICAGO 22, ILL.

KINESCOPE FOCUS SUPPLY

Patent No. 2,588,652

Morris D. Nelson, Bronx, N. Y.

(Assigned to Radio Corporation of America)

The voltage supply for electrostatic focusing poses a problem. It may be obtained by a potentiometer across the kinescope h.v. source, but the potentiometer must impose only slight drain and must be well insulated. This invention solves the problem. It requires only a high-voltage rectifier tube and few other parts.

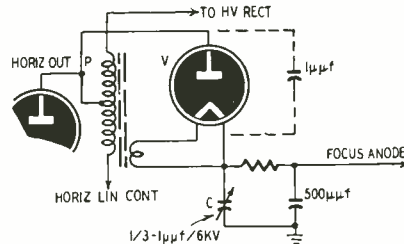

A capacitive voltage divider is connected across part of the horizontal output transformer. The peak voltage between point P and ground may be 6 kv. The divider is made up of a variable capacitor, C, and the internal capacitance of rectifier V. The latter is shown dotted. When C is set to 1 μuf, the output rectified d.c. is 3 kv. When it is set to 1/3 μuf, the output will rise to 4.5 kv. After filtering, the voltage is fed to the electrostatic focus anode.

LOW DISTORTION CATHODE FOLLOWER

Patent No. 2,592,193

Norman B. Saunders, Cambridge, Mass.

(Assigned to United States of America, as represented by the Secretary of War)

Cathode followers are known for low distortion. Under special conditions, distortion may be held as low as .01%. For such extra-low distortion, the follower d.c. plate current and the d.c. potential between cathode and plate must be constant. This circuit meets both these requirements.

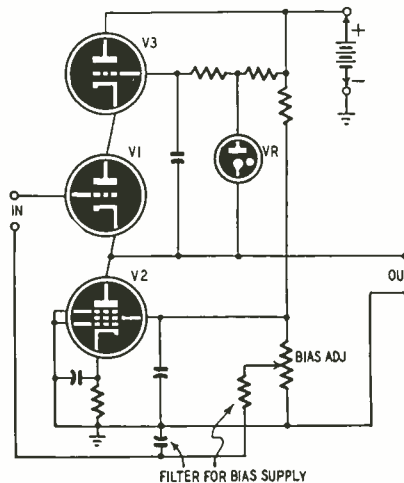

V1 is the cathode follower. Its output voltage appears across the output terminals. V2 is connected as a constant-current pentode to control the average current flowing through the follower. Regulator tube VR maintains a constant voltage between the V1 cathode and the V3 grid.

When a signal is applied to the input terminals, a signal voltage appears across the impedance formed by the external load across the output terminals paralleled by the plate-to-cathode impedance of V2. Since this impedance is in the cathode circuit of V1, a cathode-follower, the voltage on the cathode of V1 tends to follow the voltage applied to the grid. The voltage-regulator tube VR maintains a constant potential difference between the cathode of V1 and the grid of V3, therefore the signal appearing at the cathode of V1 is automatically transferred to the grid of V3.

Now, V3 is also a form of cathode follower so voltage at its cathode follows the voltage on its grid. Since the voltage between the grid of V3 and the cathode of V1 is constant, the signal voltages at the cathodes of V1 and V3 are in phase and nearly equal. The plate-cathode voltage of V1 remains substantially constant.

—end—

IT SELLS BEST because IT PERFORMS BEST DAVIS SUPER-VISION ALL-CHANNEL ANTENNA

FOR FRINGE AREA or DX With ELECTRONIC DIPOLE SEPARATORS "THE ORIGINAL ANTENNA SOLD WITH A MONEY-BACK GUARANTEE"

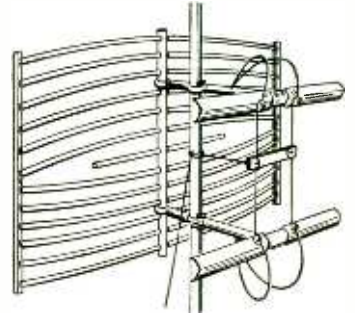

1. EXCELLENT FOR FRINGE AREA and DX RECEIVING—and broad band receiving with high gain on all channels—2 through 13.
2. CLEARER PICTURES UP TO 125 MILES OR MORE—from the station.
3. GHOST PROBLEMS REDUCED or eliminated due to excellent pattern.
4. PROVIDES 10 DB OR MORE GAIN ON HIGH CHANNELS where gain is needed most.
5. EXCELLENT FRONT TO BACK RATIO on all channels. No co-channel interference.
6. MINIMIZES INTERFERENCE: Airplane Flutter—Diathermy and Ignition—F.M.—Neon Signs—X-Ray—Industrial—Etc
7. ELIMINATES DOUBLE STACKED ARRAYS, and out-performs 2 bay yagis on low band and 4 bay yagis on high channels.
8. ONLY ONE TRANSMISSION LINE NECESSARY.
9. NO WORRY OVER POSSIBLE CHANNEL CHANGES on either high or low channels.
10. CAN BE TIPPED WITHOUT TILTING MAST to take advantage of horizontal wave lengths.
11. Can be used with ANTENNA ROTOR

AT YOUR JOBBERS, OR WRITE TO:

DAVIS ELECTRONICS 1-16
 4313 West Magnolia Blvd., Burbank, California
 SIRS: RUSH INFORMATION TO ME AS CHECKED BELOW:
 Send Free Technical Data on new SUPER-VISION ANTENNA.
 Send Name and Address of NEAREST JOBBER.
 Name _____
 Street _____
 City _____ State _____

FREE
 Write today for "How to Service T.V. Receivers" with the HICKOK VIDEO GENERATOR.
 Hickok Electrical Instrument Co.
 10814 Dupont Ave., Cleveland, Ohio

\$3.00 FOR CARTOON IDEAS
 RADIO-ELECTRONICS prints several radio cartoons every month. Readers are invited to contribute humorous radio ideas which can be used in cartoon form. It is not necessary that you draw a sketch, unless you wish.
 Address
 RADIO-CARTOONS,
 RADIO-ELECTRONICS
 25 West Broadway, New York 7, N. Y.

FIRST EDITION A SELLOUT . . . NEW EDITION A KNOCKOUT!

Brooks LIFE-SIZE Edition

#630 TV KIT BUILDER - SET OF INSTRUCTIONS

Step by Step Instructions By WALTER H. BUCHSBAUM
Compiled and Edited By MORRIS BROOKS

BUILDING YOUR OWN #630 TV CHASSIS is now simplified with this **COMPLETE SET OF BUILDING & WIRING INSTRUCTIONS**. This Edition covers all #630's, from the authentic RCA 10" SET to the latest SUPER DE LUXE 31-tube 16" to 24" RECEIVER, with all the added features.

EVERYTHING AT A GLANCE on four 25" x 38" LAYOUT CHARTS showing chassis and components in actual LIFE-SIZE with easy to follow step by step instructions right alongside the illustrations. No fumbling from one paper to another.

GUESSWORK IS ELIMINATED by specially prepared SCHEMATIC DIAGRAMS, LOCATION GUIDANCE, CODE CHARTS, ALIGNMENT PROCEDURE and TOP AND BOTTOM PHOTOGRAPHS OF A COMPLETED CHASSIS (assembled from these instructions) clearly showing placement of each component.

INDISPENSABLE for—**BUILDING, CONVERTING, MODERNIZING,** or even **TROUBLE SHOOTING ANY #630 TV RECEIVER!**

Popular priced
at only

\$2.49

Postpaid

#630 STANDARD TV KIT AT LESS THAN \$100 -

SPECIAL for SCHOOLS and TECHNICIANS!

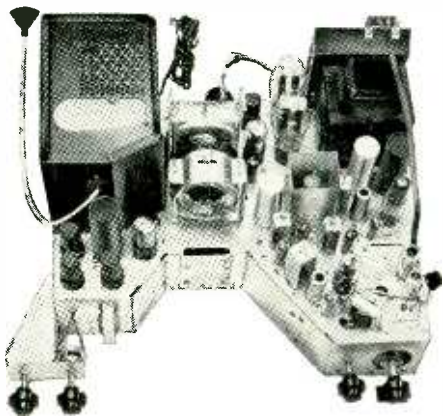

THIS OFFER MAKES TV HISTORY . . . never ever so low a price, never ever such high quality . . . Quality and improvements in components that will enable the finished chassis to operate 10", 12½" and certain 16" picture tubes . . . This STANDARD KIT consists of a complete set of parts, similar to those used in the famous RCA #630 29-tube chassis, including all tubes, speaker, resistors in correct 5%, 10%, 20% tolerances, the new Cascade tuner and the Brooks LIFE-SIZE Instructions (less CRT & wire)

only **\$93.78**

#630 SUPER DELUXE 31-TUBE TV KIT \$119.44

NOTHING BETTER AT ANY PRICE!

Operates all 16" to 24" picture tubes . . . Tops for fringe areas . . .
Peak performance for clarity, brilliance, stability and definition . . .
This **SUPER DELUXE TV KIT** consists of a complete set of parts, including the basic components of the **STANDARD KIT** plus added features, more tubes, doubler components, AGC components, Cascade tuner, Cosine 70° deflection yoke, 12" speaker, etc., including the Brooks LIFE-SIZE Instructions. (less CRT & wire)

only
\$119.44

SAVE 10%

Purchase of any **CABINET & PICTURE TUBE** with this super deluxe KIT entitles you to an extra discount of 10% off the total.

BROOKS RADIO & TV CORP., 84 Vesey St., Dept. A, New York 7, N. Y. TELEPHONE
COrtlandt 7-2359

CUSTOM-BUILT TV CABINETS FROM FACTORY TO YOU

Feast Your Eyes on Eleven Leaders in **STYLE . . . QUALITY . . . PRICE**

The **VOGUE**

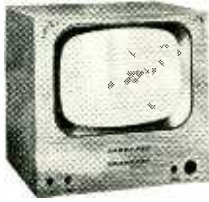

Most popular table model and the best value ever!
H-21", W-26", D-23". Wgt. 48 lbs.

\$39.89

VOGUE for 24" or 27" CRT
H-31", W-27", D-23". Wgt. 60 lbs.
\$62.54

The **STREAMLINER**

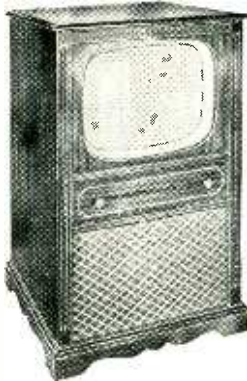

Unique with center drop panel that conceals the tuning knobs.
H-42", W-26", D-24". Wgt. 80 lbs.

\$74.98

The **WINDSOR**



Royal splendour, genuine leather inlay, hand tooled in gold.
H-42", W-26", D-24". Wgt. 100 lbs.

\$117.46

STYLED—to blend with all furniture settings and made to fit any and all TV sets.
QUALITY—mastercraft construction, in genuine mahogany or walnut.
PRICED—at wholesale to you, by our controlling interest at the factory.
Prices indicated are for the mahogany or walnut finish with any picture tube cutout from 12½" to 21". All cabinets except the **WINDSOR** and **ORIENTALE** are available in the blond finish at 10% extra. Each cabinet is delivered complete as pictured, everything (including the mask, safety glass, etc.) is all set up ready for the chassis and picture tube to slide in place and bolt down. Picture tube mounting brackets, backboard, backcup, decals and instructions are all included at no extra cost. The knob panel and chassis shelf are either drilled for the #630 or left blank to fit any other TV set. Each cabinet is carefully packed in an air cushioned carton for safe delivery directly from the factory to you. Wgt. denotes gross shipping weights.

REVOLVING TV TABLE



\$12.97

Adds a new joy to TV pleasure.
Top 22"x25" fits most TVs. Wgt. 23 lbs.

The **NEW YORKER**



Full door model. Excellent companion-piece to piano in parlor.
H-42", W-26", D-24". Wgt. 100 lbs.

\$96.87

The **MAYFAIR**

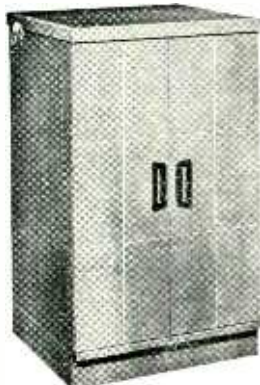

Exquisitely modern, with an elegance of simplicity in styling.
H-40", W-27", D-23". Wgt. 85 lbs.

\$98.56

The **HOLLYWOOD**



Aristocrat of TV, styled to grace the finest home. Optional with **PHONO-DRAWER** and/or **BAR** (less liquor). Inside front panel same as cabinet below.
H-41", W-31", D-24". Wgts. 125 to 150 lbs.

(less **BAR & PHONO-DRAWER**) **\$138.44**

Add \$19 for **PHONO-DRAWER COMBINATION**, \$46 for **BAR** (less liquor). \$26 for **HOLLYWOOD** for 24" or 27" CRT.

The **TOWN & COUNTRY**

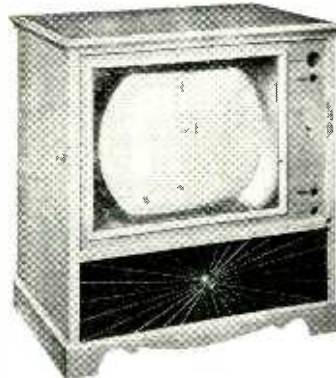

Patterned after the popular credenza. Specially made for the 24" or 27" picture tube.
H-42", W-36", D-24". Wgts. 100 to 114 lbs.

\$109.62

With **PHONO-DRAWER** (shorter grill). . \$128.62

The **MANHATTAN**



A best seller with all Mfrs. of TV with a "new look" in styling.
H-41", W-25", D-25". Wgt. 56 lbs.

\$59.37

MANHATTAN for 24" or 27" CRT
H-46½", W-27¾", D-24". Wgt. 78 lbs.

\$86.22

The **PLYMOUTH**



The choice of interior decorators, truly exquisite in every detail.
H-40", W-27", D-23". Wgt. 82 lbs.

\$105.48

The **ORIENTALE**



Work of art. Gold hand painted figures on a black lacquer finish.
H-42", W-26", D-24". Wgt. 100 lbs.

\$118.73

BROOKS RADIO & TV CORP., 84 Vesey St., Dept. A, New York 7, N. Y. TELEPHONE COrtland 7-2359

630 SUPER DELUXE 31-TUBE TV CHASSIS

NATIONALLY KNOWN MFR.
Licensed under RCA patents

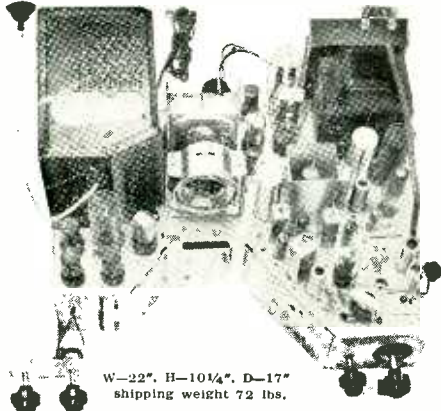

W—22", H—10 1/4", D—17"
shipping weight 72 lbs.

OPERATES ALL 16" TO 24" PICTURE TUBES

Engineered in strict adherence to the genuine
RCA #630, plus added features ★ ★ ★ ★ ★

NOTHING BETTER AT ANY PRICE!

- Standard Cascode Turret Tuner for DX
- Cosine 70° Deflection Yoke for Definition
- Original 630 Synch. Chain for Stability
- 16.5 KV for Clarity and Brilliance
- Fast Action Pulse Keyed AGC
- Large Concert-tone 12" PM Speaker

COMPLETE READY TO PLAY

Including all tubes, hardware, universal mounting brackets, etc. and our special booklet "Hints For Better Performance on your #630 Receiver." We charge no extras of any kind. Each set is factory aligned and tested. All parts are fully guaranteed for three months.

\$167.97
less C.R. Tube

FINEST STANDARD GUARANTEED PICTURE TUBES

Most desirable 4 sizes—Choice of DUMONT or SHELDON each with one full year guarantee.

17" Rect. \$29.63

shipping weight 23 lbs.

20" Rect. \$39.74

shipping weight 31 lbs.

21" Rect. \$44.68

shipping weight 38 lbs.

24" Round \$69.49

shipping weight 43 lbs.

SPECIAL COMBINATION OFFERS - SAVE 10%!

On Any Combined Purchase of a **CABINET, CHASSIS and PICTURE TUBE**

PICK any **CABINET** in the finish to suit your taste. Pick a **PICTURE TUBE** in the size that you prefer, include the **#630 SUPER DELUXE TV CHASSIS**, add the total selling price and deduct 10%

Terms: F.O.B. New York, send 20% deposit with order, balance on delivery.

BROOKS RADIO & TV CORP., 84 Vesey St., Dept. A, New York 7, N.Y. TELEPHONE
CORtlandt 7-2359

HANDY BRAID CUTTER

Sound installation men often waste a lot of time removing the heavy cotton braid which is usually used around multiconductor intercom cables. I find that I can do the job in half the usual time with the little tool shown in the drawing.

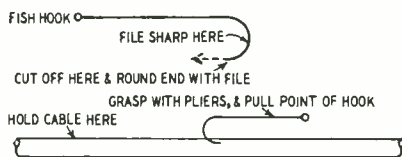

The gimmick is made from a large fishhook. Cut off the barb, sharpen the *inside* of the hook with a small file, then round off the end where the barb was clipped off. To use: Insert the point into the braid between two conductors. Grasp the shank of the hook with pliers and pull toward the end of the cable from which the braid is to be removed.
—O. C. Vidden

MULTIMETER KINK

If you are planning to construct a multimeter, select a range switch which has an extra position on each wafer. Wire the extra contacts so there is a direct short across the meter when the switch is set to the off position. This short provides enough electrodynamic damping to prevent violent movement of the pointer, thus protecting the meter against damage by sudden shocks during transit.—Charles Erwin Cohn

BRIGHTEN With The New
YOUR SALES PICTURE **KINE-LITE**
Picture Tube Pat. Pending
Brightener & Rejuvenator

Only **VIDAIRE'S Kine-Lite** operates on ANY cathode ray picture tube of 10" and larger, including electrostatic focus.

VIDAIRE'S Kine-Lite brings **\$4.95** list new brightness to TV picture tubes having low emission—permanent installation—can be re-used—simple instructions with each unit.

- ★ Renews brilliance and contrast of picture
- ★ Prolongs life of old picture tubes
- ★ Easy to install ★ No soldering necessary
- ★ For all standard tubes using duo-decal bases
- ★ No limit to tube size—10" to 30"
- ★ Standard Warranty ★ Two connecting plugs
- ★ Compact, attractive package
- ★ QUICK SELLER — EXCEPTIONAL PROFITS

Sold only through **VIDAIRE** distributors
Write for Catalog A

Vidaire Electronics Mfg. Co.
Mfrs. of TV color equipment, phone & TV amplifiers
6 E. 39th St., N. Y. 16, N. Y.
LExington 2-7372

RADELCO

LIGHTNING ARRESTOR

MODEL R-116

IT'S THE LOWEST PRICE UNDERWRITERS' LISTED ARRESTOR ON THE MARKET

ORDER FROM YOUR NEAREST PARTS JOBBER

LIST PRICE
90¢

VITALITY



for
CRT
PUT
NEW
LIFE

into weak
Picture Tubes
with the famous



TRANSVISION

TESTER-REACTIVATOR

EARN UP TO \$100 A WEEK
part time — more full time—
with this great instrument!

(Pat. Applied For)

- *Renews Brightness, Sharpness, and Detail of Old Dim CR Tubes. Results are truly astounding.*
- *You don't remove tube from set, or from its carton. No time lost.*
- **It's also an accurate TESTER:**
Again, without removing the Picture Tube from set or carton, use this fine instrument to *measure Cathode emission, locate shorts between elements, locate high resistance shorts or leakage as high as 3 megohms. 110V-60 cycles; wt. 3 lbs. It's a rugged, dependable, effective instrument. So get the genuine—order direct from TRANSVISION today!*

SATISFACTION GUARANTEED
or money refunded if you return
the instrument in 10 days in good
condition.

\$19⁹⁵
NET

—RUSH THIS COUPON
TRANSVISION, INC.
DEPT. RE-9V NEW ROCHELLE, N. Y.

() Send me _____ CR Tube Tester-Reactivator(s).

() Enclosed find \$_____ deposit Balance C.O.D.

() Enclosed find \$_____ in full. Send prepaid

Name _____

Address _____

City _____ State _____

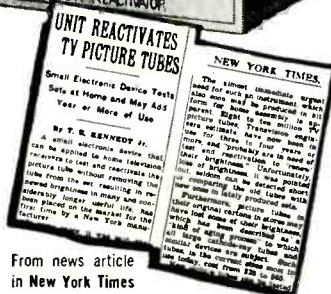
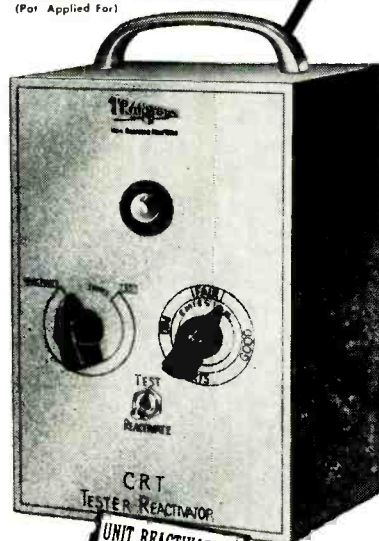

From news article
in New York Times

TRANSVISION, INC. • NEW ROCHELLE, N. Y.

USING RADIO AS TUNER

Many music lovers now have high-fidelity amplifiers which they use for phonograph reproduction. For radio reception, many of them have to be content with the poorer quality reproduction from the single-ended audio system and midget speaker used in many AM and FM radios. If the set has a phono input jack and switch, it is a simple matter to rewire the input circuit to the a.f. amplifier section so the set can be used as a tuner or straight radio simply by throwing a switch.

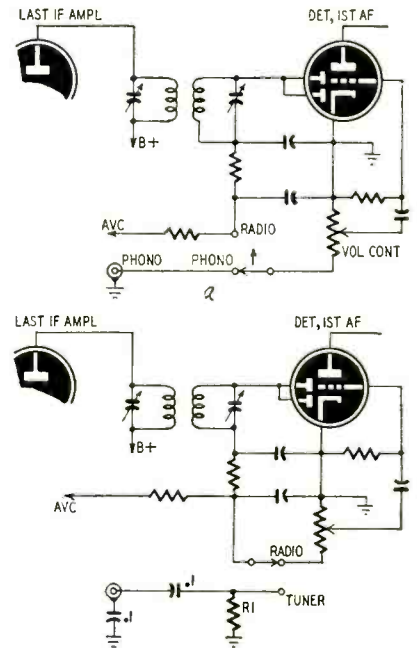

The drawing at *a* shows the detector, first audio, and phono input circuits of a typical receiver. The diagram at *b* shows how the arm of the PHONO-RADIO switch is removed from the hot side of the volume control and connected to a point on the detector load. Resistor R1 must be added to complete the detector load when the switch is in the TUNER position. The value of R1 should be the same as that of the volume control.—
William Dervin

HIGH-GAIN FM ANTENNA

Reception of FM signals originating at stations 100 miles or more from the receiver is not unusual in good receiving locations. However, multiple paths often cause the signals to cancel at the receiving antenna and cause severe audio distortion. To eliminate this, we may either use a beam type antenna such as a Yagi or we use several interconnected dipoles spaced so that complete signal cancellation will not occur on all of them at any one time.

A 4-dipole array of this type is described in *Sylvania News*. Details of its construction are shown in the diagram. The dipoles, cut for the center of the FM band, are constructed from No. 8 aluminum wire. Connecting leads A may be any convenient length as long as all lengths are equal. Leads marked B are quarter-wavelength matching sections. They are each 26 inches long. All connecting leads are 300-ohm rib-

bon. Be sure that the phasing connections are as shown. The right sides of the dipoles are connected together and

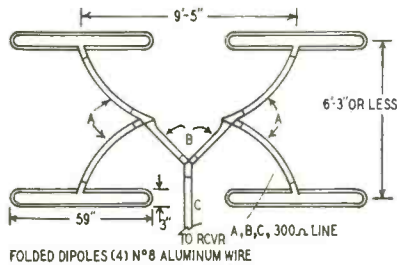

brought to the same side of the lead-in. Orient all dipoles at right angles to the direction of the desired signals.

RETRACE BLANKING KINKS

I have developed a method of applying vertical retrace blanking to some sets without pulling the chassis. On the Zenith G2952R and similar models, I simply connect a 180,000-ohm resistor from the picture tube cathode (pin 11) to pin 9 of the dummy Phoneyvision plug on the rear of the chassis. A .002-μf capacitor is connected between this pin and the plate of the vertical output stage. The vertical signal is tapped off at this point and applied to the cathode of the picture tube to blank the retrace lines.

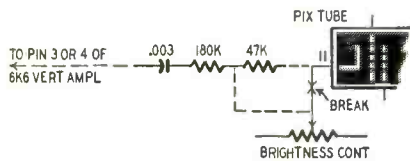

The diagram shows the details of a similar modification which I have made on Emerson 571 and 606 models. The .003-μf capacitor and the 47,000- and 180,000-ohm resistors are assembled on a small terminal strip. The lead between the picture-tube cathode and the brightness control is broken near the socket and the leads from the ends of the 47,000-ohm resistor are connected as shown by the dashed lines. The lead from the free end of the .003-μf capacitor is around either pin 3 or pin 4 of the 6K6 vertical amplifier tube. There is d.c. on this lead, so make sure that it does not short to the chassis.

—F. H. Hanley

CARRYING TV MASTS

If you are wondering how to get that length of TV mast or light wooden pole home without scratching the family car, try a set of the rubber suction cups and web straps used for carrying skis and fishing poles. You can purchase a set from an automobile appliance dealer for less than a single touch-up job would cost.—Robert H. Mitchell, W6TZB

MIDGET SOLDERING IRON

When some of the midget or pencil-type soldering irons are used regularly, their wooden handles char and the barrel comes loose so the iron is practically useless. The iron can be repaired by packing asbestos furnace cement into the space between the barrel and the handle and letting it dry before handling.—S. H. Beverage, W1MGP

—end—

TV DIRECT FROM THIS GREAT FACTORY TO YOU
BRINGS YOU
Finest Quality at Lowest Prices



TRANSVISION

TV KITS, WIRED CHASSIS, and SETS
CABINETS, COMPONENTS, INSTRUMENTS, and ACCESSORIES
NEW LOW PRICES
on top quality TV Picture Tubes.

• FREE—VALUABLE PREMIUMS:

With every Transvision tube you buy, you get a Merchandise Premium Coupon of real value. Write for list today.

• TRADE-IN ALLOWANCE on old tubes: Make from \$2.50 to \$5.00 glass allowance on each "dud."

• FULL 2 YR GUARANTEE:

Only Transvision gives you a Guarantee for 24 months.

COMPARE: Get the full details on the Transvision tube deal today.

FREE BOOKLET: "INSIDE CRT, or What You Should Know about Picture Tubes". Written by CRT experts, illustrated. It will MAKE MONEY FOR YOU. WRITE FOR IT.



New... TRANSVISION Picture Tube PRICES

Tube Type	Cost, WITH GLASS allowance	Cost, WITHOUT GLASS allowance
10BP4	\$11.80	\$13.80
12 1/2" Glass (any type)	13.45	15.75
12 1/2" Metal (any type)	13.95	15.25
14BP4 (any type)	16.50	18.25
16" Metal (any type)	19.90	23.20
16" Round or Rect. (any type)	18.90	22.25
17BP4	18.90	22.25
19" Metal or Glass (any type)	23.95	28.95
20CP4	23.95	31.95

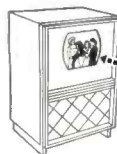

SPECIAL!



REMOTE CONTROL TV CHASSIS

Here's the finest buy in Remote Control TV. Unit is all-electronic; no troublesome mechanical parts. Gives complete operating control of set. Plus—the latest Transvision A-4 Wired TV Chassis; completely aligned; ready to plug in. Has AFC and AGC. Top quality reception, even in fringe areas. 17" A-4 TV Chassis, remote control, and CRT, net \$199. 20" A-4 TV Chassis, remote control, and CRT, net 219. With Du Mont Tuner and FM radio, add..... 10

BEAUTIFUL TV CONSOLES

Ideal for Custom-Building or Conversion. Factory prices start from \$49. Send for Cabinet Catalog now.

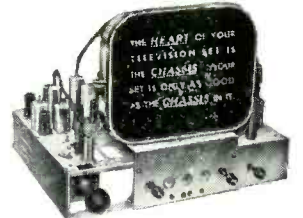

FIELD STRENGTH METER AT NEW LOW PRICE

Improve TV installations; save half the work with the Transvision Field Strength Meter. Especially good for fringe areas—measures field strength as low as 10 microvolts. \$59 net. Model FSM-1, complete with tubes.



U. H. F. ADAPTERS

will be available for all Transvision Sets and Kits. Write for Factory Agent Plan

MULTI-SET CONNECTORS

feed up to 5 TV Sets from 1 Antenna. Prices: Multi-Set Conn. for 2 sets \$4.95 list* For 3 or 4 sets 7.95 list* *Dealers, write for discounts

FREE: EXTRA INCOME EVERY MONTH from hints in "TV and Electronics Notes." Request FREE Or send 50c to cover cost of Subscription. Monthly issues are gold mines of info on New Products, Sales Service, Conversion, etc. WRITE DEPT. RE9 TODAY!

TRANSVISION, INC. NEW ROCHELLE, N. Y.

Tel-a-Ray's Swing-Over Tower is the easiest, quickest way to good reception

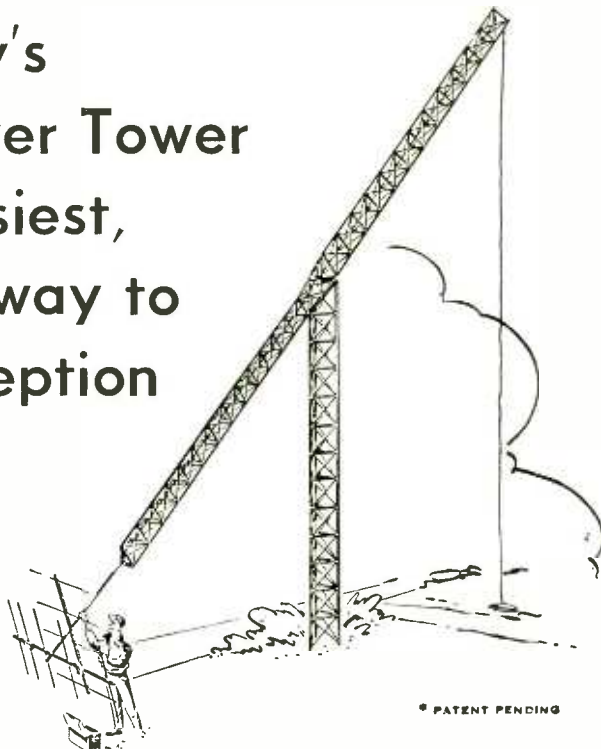

Other Tel-a-Ray products that will bring you the best TV possible: The Model T and TD antennas, the Butterfly, the All-Purpose antenna and the Pre-Amplifier. Get the story of good reception—call or write today.

Tel-a-Ray
ENTERPRISES, INCORPORATED
 BOX 3320
 HENDERSON, KENTUCKY

TRADE MARK

LEARN

Television-Radio Electricity

REFRIGERATION-ELECTRONICS

IN THE GREAT SHOPS OF **COYNE**

**TRAIN QUICKLY! OLDEST, BEST
EQUIPPED SCHOOL of ITS KIND in U.S.
Draft Age and Older Men...**

Come to the Great Shops of Coyne in Chicago. Get practical training in TELEVISION-RADIO or ELECTRICITY—vital in Defense Program. Prepare now for a better job or better service rating.

START NOW—PAY LATER

You can finance most of your tuition, pay for it later in easy monthly payments. Special plan for men of Draft Age. Part time employment service available. **FREE BOOK** Clip coupon for Big Free Illustrated Book. Indicate below, course that interests you. No salesman will call. Act NOW.

COYNE SCHOOL
 B. W. Cooke, President
 A TECHNICAL TRADE
 INSTITUTE CHARTERED
 NOT FOR PROFIT
 Established 1899
 500 S. Paulina, Chicago

**ELECTRICITY ★ TELEVISION
 RADIO ★ REFRIGERATION ★ ELECTRONICS**

B. W. COOKE, Pres.
COYNE School
 500 S. Paulina St., Chicago 12, Ill. Dept. 62-81H

Send FREE BOOK and full details on:

TELEVISION-RADIO ELECTRICITY

NAME

ADDRESS

CITY

STATE

Examine FREE PULSE TECHNIQUES

by S. Moskowitz and J. Racker
 Get this new self-training book for 10 days' free examination



Here is everything you need to know about pulse techniques—a subject of increasing importance in television, communications, and all electronic equipment. This book covers transient response of linear networks, design of pulse networks, pulse shaping and clamp circuits, pulse generation, measurement, and instruments, pulse communication systems, and aerial navigation aids.

PARTIAL CONTENTS: Fourier-transform method. Response of an ideal low-pass filter to a step voltage. Physical significance of response curves. Response to a pulse series. Determination of network response by Fourier transforms. Use of partial fractions in the solution of transform problems. Laplacian transform and Inverse Laplacian of a step voltage. Typical network problems using L transforms. High-pass RC filter. Pulse transformers. Step-voltage build-up time response of a step-down transformer. Delay-time response. Special coaxial delay lines. Design of lumped lines. Supersonic delay lines. Shunt-peaking amplifier. Four-terminal coupling networks. Transmission-line amplifiers. Cathode follower. Limiter circuits. Clipping circuits. Peak-riding clipper. Integrating circuits. Positive-bias restorer. Electron-coupled pulse oscillators. Relaxation oscillators. Multi-vibrators. Sweep circuits. Time calibration. Pulse-counting systems. Commutation. Modulation. Synchronization. Commercial pulse communication system. Introduction to radar systems. Timing unit. Radar receiver. Navar system. Loran system. Get this authoritative handbook today! Coupon below brings you "Pulse Techniques" on FREE trial for 10 days. Mail it NOW!

MAIL COUPON TODAY

Prentice-Hall, Inc., Dept. M-RE-952
 70 Fifth Avenue, New York 11, N.Y.

Please send me a copy of PULSE TECHNIQUES for FREE examination. Within 10 days I will either return the book and owe nothing, or keep it and remit \$2.65 down (plus postage) and \$2 monthly for 2 months.

Name

Address

City

Zone

State

PHASE INVERTING DETECTOR

A push-pull output stage is often used in high-fidelity AM receivers. In such sets, it is normal procedure to use a phase inverter tube to drive the push-pull grids. In a recent issue of *Radio Constructor* (London, England), G. A. French points out that local stations most often listened to by hi-fi fans develop enough voltage at the output of the detector to drive the grids of a push-pull output stage. So, to eliminate the phase inverter tube, he has developed the phase-inverting detector shown in the diagram.

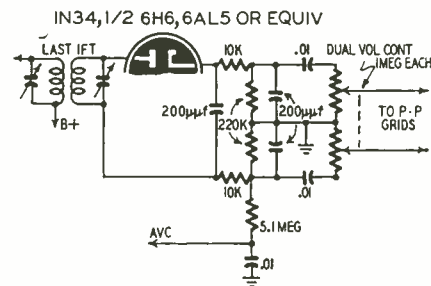

The diode load is the two 220,000-ohm resistors connected in series. The voltage developed across them is split into two equal signals of opposite polarity by the ground at the center of the load. The 10,000-ohm resistors and filter capacitors are arranged symmetrically around the center-tapped load. The 5.1-megohm resistor and the .01- μ f capacitor are a.v.c. filter components. These may be omitted if the set does not use a.v.c. or if a.v.c. is supplied from a separate rectifier.

This circuit eliminates the drain of a phase inverter tube and the possibility of hum caused by heater-cathode leakage. If hum is introduced through the heater-cathode circuit of the detector tube, it can be eliminated by replacing the tube with a germanium diode.

(This item, while not new, has given good service, and is worthy of wider use. It was described in the article "12-Tube High-Fidelity Receiver" in *RADIO-CRAFT*, February, 1936.—*Editor*)

NOVEL SENSITIVITY CONTROL

In many receivers, the sensitivity or r.f. gain control is a potentiometer in series with the cathode return of an r.f. or i.f. amplifier stage. Greater control of the gain can be obtained by modifying the circuit so the gain control is a bleeder connected between the screen grid and ground as shown in the diagram. When the control is turned toward the minimum-gain position, the voltage between screen and cathode is reduced, thus augmenting the gain reduction caused by the increase in grid bias. The dropping resistor R should be proportioned to give full screen voltage when the gain control is on full.

—Charles Erwin Cohn

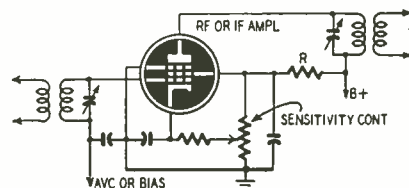

BLAK-RAY SELF-FILTERING ULTRA VIOLET LAMP



Experimenters have been looking for a reasonably priced Ultra-Violet lamp that would supply a rich quality radiation with minimum power consumption. The BLAK-RAY 4-watt lamp, model X-4, complete with U-V tube, fills these requirements admirably. Over 3000 substances are affected by the so-called "black light" and glow visibly or fluoresce in a weird manner when illuminated by the U-V lamp here illustrated. This lamp gives long-wave ultra-violet radiation having a wavelength of 3654 to 4000 angstrom units. Some of the substances made to fluoresce visibly when illuminated by U-V light are certain woods, oils, minerals, milkstone, cloth, paints, plastics, yarn, drugs, crayons, etc. This lamp is self-filtering and the invisible U-V rays are harmless to the eyes and skin. The lamp is equipped with spectral-finish aluminum reflector. The lamp consumes only 4 watts and can be plugged into any 110 volt 50-60 cycle alternating current outlet. Will give 2000 to 3000 hours of service. It weighs but 1 3/4 lbs. and has a convenient adjustable handle. The lamp is approved by the Underwriters Laboratories and has a built-in transformer so that it may be safely used for long periods when necessary. Extra U-V tubes are available at nominal cost. The outer casing of the lamp is richly finished and very sturdy.

Ship wt. 4 lbs.
ITEM NO. 125
UNUSUAL BUY **\$14.75**

POWERFUL ALL PURPOSE MOTOR



Sturdy shaded pole A.C. induction motor. 15 watts, 3000 rpm. 3"x2"x1 1/4"; 4 mounting studs; 7/8" shaft, 3/16" diameter; 110-120 volts, 50-60 cycles, A.C. only. When geared down, this unit can operate an 18" turntable with a 200 lb. dead weight. Use it for fans, displays, timers and other purposes. Ship. wt. 2 lbs.

ITEM NO. 147
UNUSUAL BUY **\$2.45**

WATTHOUR METER

Loading makes — completely overhauled, ready for service. 100-110 volts, 60 cycles, 2-wire A.C. 5 amp. Heavy metal case 8 1/2" x 6 1/4" x 5". Easy to install. Ship. wt. 14 lbs.



ITEM NO. 33
NOW ONLY **\$4.50**

WESTERN ELECTRIC BREAST MIKE



Lightweight 1 lb. carbon microphone. Aircraft type. Breastplate mounting, adjustable 2-way swivel. Easily fastened straps. For home broadcasts, communications etc. Complete with 6 foot cord, hard rubber plug. Sheradized plate, non-rusting finish. Ship. wt. 2 lbs.

ITEM NO. 152
NEW LOW PRICE **\$1.75**

AMAZING BLACK LIGHT



250-watt ultra-violet light source. Makes fluorescent articles glow in the dark. Fits any lamp socket. For experimenting, entertaining, unusual lighting effects. Ship. wt. 2 lbs.

ITEM NO. 87
A SAVING AT **\$2.45**

HUNSON SPECIALTIES CO.

40 West Broadway, Dept. RE-9-52
New York 7, N. Y.

I am enclosing full remittance for items circled below. (Be sure to include shipping charges.)

OR, my deposit of \$ Ship balance C.O.D.
MINIMUM C.O.D. ORDER \$5.00.

C.O.D. ORDERS ACCEPTED ONLY WITH 20% DEPOSIT
INCLUDE SHIPPING CHARGES.

Circle Items Wanted

87 147 33 152 125

Name Please Print Clearly

Address

City Zone State

NOVEL A.V.C. CIRCUITS

Some receivers use a separate a.v.c. rectifier like that shown in Fig. 1 instead of taking the a.v.c. voltage from

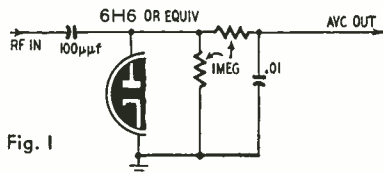

Fig. 1

the audio-detector load resistor. This separate diode rectifier can be eliminated in a number of circuits which are controlled by the voltage on the a.v.c. line. Tuning indicators and squelch-control circuits are typical of these. The circuit at *a* in Fig. 2 is a typical electron-ray tuning indicator arrangement.

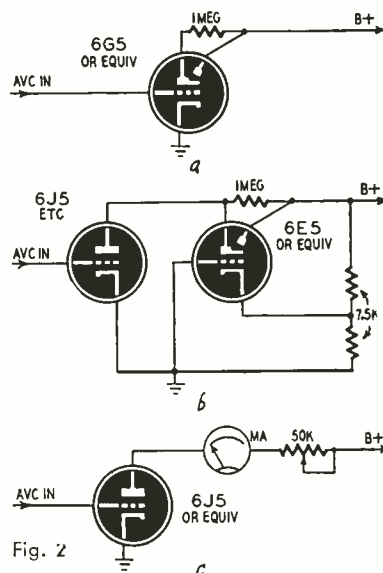

Fig. 2

The circuit at *b* is for the expanded shadow, and *c* shows a simple S meter.

In each of these circuits, we can substitute the control grid of the tube for the plate of the a.v.c. rectifier. The resulting circuits are shown in Fig. 3. The triode grids still get the required

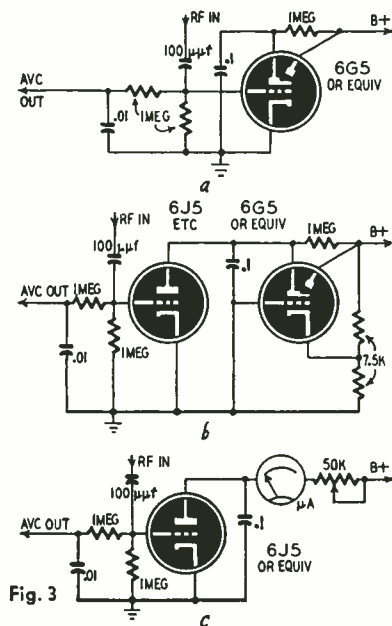
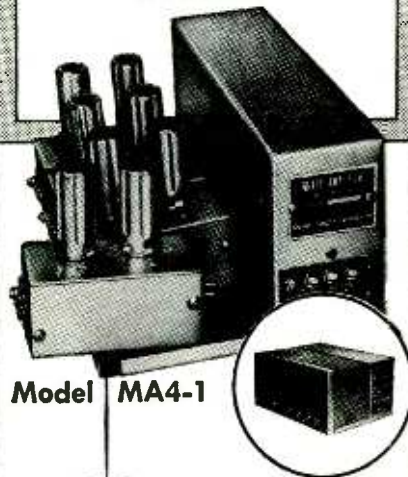

Fig. 3

"PACKAGED ENGINEERING" at Its Best! For the TV Technician

The B-T MIXER-AMPLIFIER SYSTEM



Model MA4-1

For All VHF and UHF Multi-Antenna Problems

Designed for the Service Technician to enable him to plan and make any installation . . . whether a single receiver or a complete 2000-set Master Antenna System . . . at lower cost, and without outside engineering.

The B-T MA4-1 is a wide-band, all-channel TV signal mixer for feeding 5 antennas to 1 TV receiver or distribution system. One input is broad-band for signals requiring no pre-amplification, and the remaining 4 accommodate separate plug-in strip assemblies. All terminals have 75 and 300 ohm connections. Several units may be ganged to serve any number of antennas.

B-T PLUG-IN STRIPS

Channel Strip CS-1 is a 2-tube (6AB4-6CB6), single channel, highly selective amplifier with a gain of at least 17 db., one strip for each TV channel.

The UHF Converter, UC-1 is designed for lowering UHF signals to existing TV frequencies, permitting UHF reception on present TV receivers.

Eliminates all need for rotators, separate boosters, converters, and other costly projects.

Once connected the MA4-1 performs without further attention . . . no switching . . . no adjustments.

LIST PRICES:

Model MA4-1 (less plug-in strips) **\$52.50**
Channel Strip CS-1 (specify channel) **19.50**
UHF Converters UC-1 to be announced
Standard RTMA Warranties Apply.



For the Complete 'Packaged Engineering' story, ask about B-T Signal Amplifiers and B-T Distribution Amplifiers at your local Distributor, or write to Service Department, F

B-LONDER-TONGUE LABS. inc.
Westfield 1, New Jersey

EASY LOW-COST WAY
to own a
PROFESSIONAL QUALITY
tapeMaster
TAPE
RECORDER

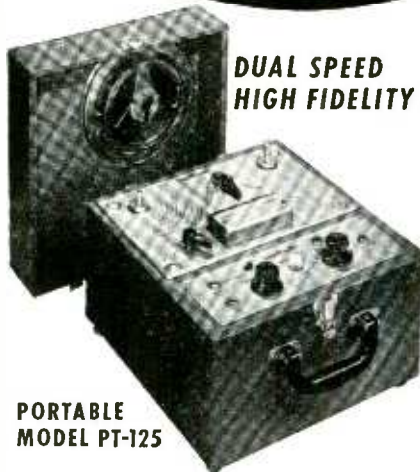

DUAL SPEED
HIGH FIDELITY

PORTABLE
MODEL PT-125

Use with Your Own Audio Amplifier,
Radio or Radio-Phono Combination,
or with new **tapeMaster Model**
SA-13 Power Amplifier and Speaker.

For the first time, a completely flexible professional quality tape recorder like this—at such economical cost! Advanced engineering and customized design make **tapeMaster** a natural choice of recording enthusiasts everywhere.

Built to RTMA Standards • Dual Track Dual Speed—7.5" and 3.75" sec. • Fast Forward and Rewind • Direct Threading of Tape • Push-Pull Supersonic Bias-Erase Response 50-8000 cps ± 3 db at 7.5 and 50-5000 cps at 3.75 • Inputs for Radio, Phono and Mike • Full Monitoring • Neon Record Level Indicator • For 105-125 V 60 cycle AC (Also available for 110-220 V 50 cycle AC)

Complete with 5" spool of plastic tape and 7" empty take-up spool, in sturdy carrying case covered with waterproof leatherette, less audio amplifier and microphone. Size: 12½" x 12" x 9½" high. **\$99.50**
Net Price.....

(Slightly Higher West and South)

Tape Transport Mechanism and Matching Pre-Amplifier with Push-Pull Supersonic Bias-Erase Oscillator also available individually for custom installations.

MODEL SA-13
POWER AMPLIFIER
AND SPEAKER

Portable companion to the PT-125 tape recorder. Combines a special type speaker, new amplifier design, and effective principle of baffling. Amplifier response ± 1 db 30-15,000 cps. Peak output 8 watts. Has separate bass and treble control. 12" x 9½" x 18½" high. **\$79.50**
Net Price.....



Send for **FREE Bulletin 102-A**

tapeMaster inc.
13 W. HUBBARD ST. • CHICAGO 10, ILL.

Export: Scheel International, Inc.
Chicago 18, U.S.A. • Cable: Harscheel

a.v.c. voltage but they rectify it themselves. There is still a.f. voltage on the grids. This is usually eliminated by the a.v.c. filter network in the more conventional circuits. In the electron-ray tuning circuits, the audio signal may cause a fuzzy pattern. In this case, a 0.1- μ f capacitor from the triode plate to ground will smooth it out. In the S-meter circuit (Fig. 3-c) the inertia of the pointer may give sufficient filtering. If the pointer vibrates with modulation, a 1.0- μ f capacitor between the plate and ground will stop it.—*John Sareda.*

SHARP PULSE GENERATOR

This circuit, described by Messrs. Benson and Lusher in *Electronic Engineering* (London, England), produces very sharp pulses of a nature not easily obtainable with clippers and more conventional pulse-forming devices. When a positive pulse is applied to the input terminals, the tuned circuit consisting of L and C_s is shocked into oscillation. The circuit is tuned by C_s which is the sum of the plate-cathode capacitance of the diode and the distributed capacitance of the coil.

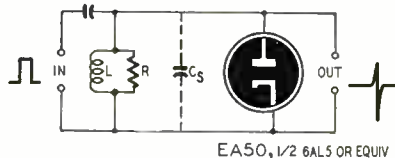

Resistor R damps the oscillations and shortens the duration of the wave train. The diode clips the positive peaks.

The rise time and amplitude of the output pulse depend on the values of the coil and the damping resistor.

When a 20-volt, 6,500-cycle pulse is applied to the input, and R is 3,000 ohms, the relationships between inductance, rise time, and output voltage are as shown in the table.

Inductance (μ h)	Rise time (μ sec)	Amplitude (volts)
400	0.8	1.60
180	0.6	1.35
33	0.5	0.30

If a positive output pulse is required, reverse the connections to plate and cathode of the diode. If further amplification is needed, substitute the grid of a triode for the diode plate in the diagram. The plate of the triode is connected to B plus through the usual plate load resistor and the output is taken from the plate through a suitable blocking capacitor.

EFFICIENT WHISTLE FILTER

The average broadcast receiver or tuner lacks the selectivity required to pull in weak signals without heterodynes at the high-frequency end of the broadcast band. Since there is little that we can do to increase the selectivity without practically rebuilding the set, the only solution is to filter out the annoying whistles without adversely affecting the audio response of the set.

Details on constructing a heterodyne filter—sometimes called a "tweet" filter—are given in the diagram reprinted

For **BETTER PERFORMANCE**
For **LASTING PERFORMANCE**

ALWAYS INSTALL
QUAM
Adjust-A-Cone
SPEAKERS

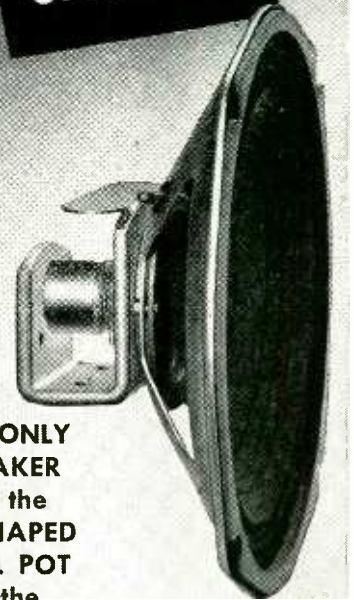

The **ONLY**
SPEAKER
with the
U-SHAPED
COIL POT
and the
ADJUST-A-CONE VOICE COIL

Write for Catalog
QUAM-NICHOLS CO.
521 E. 33rd Place
CHICAGO 16, ILLINOIS

Also Manufacturers of
QUAM Focalizer Units
Ion Traps, and
Tru-Match Transformers

500 FORMULAS TO SUCCESS

MANY million dollar firms started with a single formula, for which they paid a big price. Here you have 500—no less—tried and tested formulas, recipes and processes for making things... all at the ridiculously low price of 25c. Here is your opportunity to start a business with but a few dollars' capital and with undreamed of profits in prospect. You can also use these formulas in your own home to cut household expenses to the bone. Or you can put them to use in your workshop to cut costs as much as 100%. Quit paying out many dollars in profits to manufacturers, wholesalers, and dealers, when you can make the same thing yourself for a few cents. It's so easy when you follow our simple instructions.

66 PAGES. 47,000 WORDS IN TEXT
Send for "500 FORMULAS AND RECIPES" today. Enclose 25c, that's all! You won't be asked for another cent now or later. Sold on a money-back guarantee.

NATIONAL PLANS COMPANY
1966R Broadway, New York 23, N. Y.

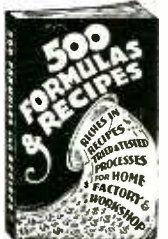

from *Radio Constructor* (London, England). The unit consists of a parallel-tuned trap designed to be inserted between the first and second a.f. stages in a receiver, or between the tuner output and the input to the first audio amplifier stage.

The circuit is tuned to the interfering frequency by varying the capacitance or the inductance.

The former is usually found to be

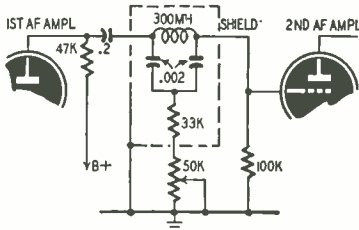

the simplest unless you can get a coil (a 300-mh r.f. choke will do) with the required inductance and a variable powdered-iron core. With a fixed inductance, each of the .002- μ f capacitors may be made up from a .001- μ f mica capacitor paralleled by a 360-1,000- μ f mica variable capacitor of the type used for oscillator padding.

The L-C Circuit is sensitive to hum pickup so it should be carefully shielded. After tuning the network to the interference frequency, adjust the 50,000-ohm variable resistor for optimum results (greatest reduction in whistle with least deterioration of signal).

ORDER BY MAIL
From **"WHOLESALE"**

September Special!
BOOSTER PRICES SLASHED!
Masco Sky Chief

Features one tuning control. Takes ohm twin lead or 75 ohm coaxial. Two 6J6's and selenium rectifier. UL approved. Reg. \$24.30

16.95

LOOK AT THESE BOOSTER BARGAINS!

Reg.	Model	Special Price
45.33	Masco Super Sky Chief	33.24
20.97	Standard Model B-51	15.37
23.95	National Model TVB-2B	17.57
19.50	Astatic Model BT-1	14.30
20.97	Astatic Model BT-2	15.37
34.50	Turner Model TV-1	25.30
17.97	Very well known make	13.17
26.97	Auto Booster model 1T75A	
	Fully automatic for all channels. Requires no tuning	19.77

Address Orders to Dept. RE-9
Write For FREE FYI Bulletin

WHOLESALE
RADIO PARTS CO., Inc.
311 W. Baltimore St.
BALTIMORE 1, MD.

BC 605 INTERCOM
INTERPHONE AMPLIFIER
Easily converted to an ideal Inter-Com. communications set for office, home, or factory. Original New w/conversion. Diagram \$4.75

SELENIUM RECTIFIER
F. W. BRIDGE
UP TO 18 VAC IN—
UP TO 14 VDC OUT
2A \$2.50
4A 4.00
6A 6.00
10A 7.50
12A 9.00
24A 18.00
UP TO 36 VAC IN—
UP TO 28 VDC OUT
1A \$3.00
2A 4.00
5A 10.00
10A 14.50
12A 18.00
24A 36.00
UP TO 54 VAC IN—
UP TO 42 VDC OUT
2A \$6.50
4A 8.50
UP TO 120 VAC IN—
UP TO 100 VDC OUT
2A \$11.00
10A 45.00
12A 60.00
Special Rectifiers
On Request
Hi-Current Chokes
.1 HY—12 Amp—0.46
Ohms \$14.95
.01 HY—2.5 Amp—
Cased \$2.25
LO-VOLT. XFMR'S
Primaries 115v.
60 Cycle
8v-1.5A \$1.19
16v-5A 3.75
20v/10A 3.95

RU/GF COIL SETS
SINGLE BAND RCVR UNITS
BAND FREQUENCY
L 400— 800 KC
C 545— 850 KC
D 850— 1330 KC
E 1330— 2040 KC
F 2040— 3000 KC
G 3000— 4525 KC
H 4000— 6000 KC
N 5200— 7700 KC
K 6000— 9050 KC
N 9050—13,375 KC
PRICE: \$1.50 EACH

RCVR. DUAL BAND
400-800 KC 6000-9050 KC
540-830 KC 5200-7700 KC
195-290 KC 290-435 KC
540-830 KC 540-830 KC
PRICE: \$2.25 EACH

RU/GF XMTR COIL
2000-2500 KC PRICE:
3000-3875 KC \$1.79
3875-4525 KC \$1.79
6000-7350 KC each
7350-9050 KC each

ACCESSORIES
REMOTE TUNING BOX TYPE, CW-23012 \$1.75
XMTR. CONTROL. BOX, CW-23007. 1.69
RCVR. SWITCH BOX, CW-23006A. 1.75

UNIVERSAL POWER XFMR
Pri: Vibrator Input @ 6 12/24/110 VDC. AC
Input 110/220-V @ 60 CY. Sec: 230-0-230
V—40 MA 6.3V—1.8A. \$1.49
As shown

Send M.O. or Check. Shipping Chgs. C.O.D.
COMMUNICATIONS EQUIPMENT CO.
131 Liberty St. Dept. C-9 New York City 7, N. Y.

Just Out

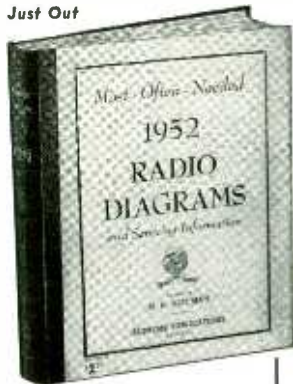

New 1952 Manual

Be prepared to repair quickly all new 1952 radio receivers. In this big single volume you have easy-to-use, extra large schematics, needed alignment data, replacement parts lists, voltage values and information on stage gain, location of trimmers, and dial stringing, for almost every recently released radio. Makes toughest jobs amazingly easy. Find all faults in a jiffy. Speed-up all repairs. The time saved on your very next job will pay the \$2.50 bargain price for the complete manual — after that you use it FREE. A worthy companion to the 11 previous volumes used by over 131,000 shrewd and experienced radio men. Giant size 8½" x 11", complete with index. Manual style, \$2.50 sturdy binding. Price, only

\$2.50

New SUPREME 1952 Radio Manual
GET IT AT YOUR RADIO JOBBER OR ORDER BY MAIL

Now you can benefit and save money with Supreme amazing scoop of 1952. This one giant volume has all the service data you need on all recent radio sets. A full year of models of all popular makes, home and auto sets, portable radios, combinations, changers, all included. The full price for this mammoth 1952 manual is only \$2.50, nothing else to buy for a whole year. Other Supreme radio service volumes for previous years (mostly at \$2) and TV manuals are described below and at right.

SUPREME RADIO MANUALS FOR PREVIOUS YEARS

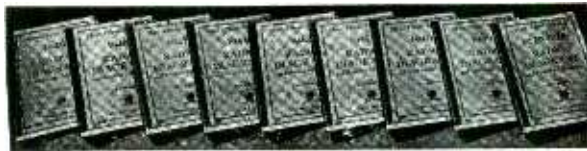

1951 1950 1949 1948 1947 1946 1942 1941 1940 1939
SUPREME Most-Often-Needed RADIO DIAGRAMS.
Each Manual only \$2 ('52-'49, \$2.50); 192 pages of diagrams, alignment data, voltage values, parts lists, and service hints; large size 8½" x 11". To order, see coupon below.

BIGGEST VALUES IN SERVICE DATA

Here is your lowest-priced service information. Use Supreme manuals to repair all radios faster, better, easier; save time and make more money. Covers all popular sets from old-timers to new 1952 models. Be wise, use these manuals to get all needed diagrams, parts lists, alignment data, and service hints, at smallest cost. Send *no-risk* coupon at right.

SUPREME TELEVISION SERIES

Here is your complete source of television service data. These TV manuals at only \$3 and \$2 each are amazing bargains and defy competition. Each manual covers a whole year of models using original factory material. Includes giant double-spread circuits and blueprints, alignment procedure, voltage charts, test patterns, waveforms, factory revisions, and helpful service hints. Select volumes from list below and send *no-risk* coupon.

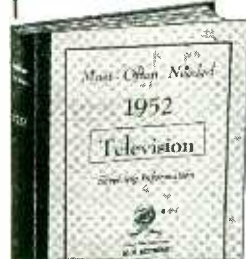

1952 TV, \$3

New giant volume of TV factory data has everything you need on recent sets. 192 pages, 8½ x 11", + double-spread diagrams. Only...\$3
1951 TV Manual, \$3
1950 TV Manual, \$3
1949 TV Manual, \$3
1948 TV Manual, \$3
1947 FM & TV, \$2

NO-RISK TRIAL ORDER COUPON

SUPREME PUBLICATIONS, 3727 W. 13 St., Chicago 23, ILL.

- Radio Diagram Manuals**
- New 1952 Manual, \$2.50
 - 1951 Radio
 - 1950 Manual
 - 1949 Radio
 - 1948
 - 1947
 - 1946
 - 1942
 - 1941
 - 1940
 - 1939
 - 1926-1938 Manual, \$2.50
- \$2.50**
PRICED AT ONLY \$2 EACH

Send Radio Manuals checked at left and TV Manuals below. Satisfaction guaranteed or money back.

- 1952 Television Manual, \$3.
- 1951 TV, \$3.
- 1950 Television Manual, \$3.
- 1949 TV, \$3.
- 1948 TV, \$3.
- 1947 TV & FM, only \$2.

I am enclosing \$..... Send postpaid.
 Send C.O.D. I am enclosing \$... deposit.

Name:
Address:

Supreme Publications
Sold by all Leading Radio Jobbers

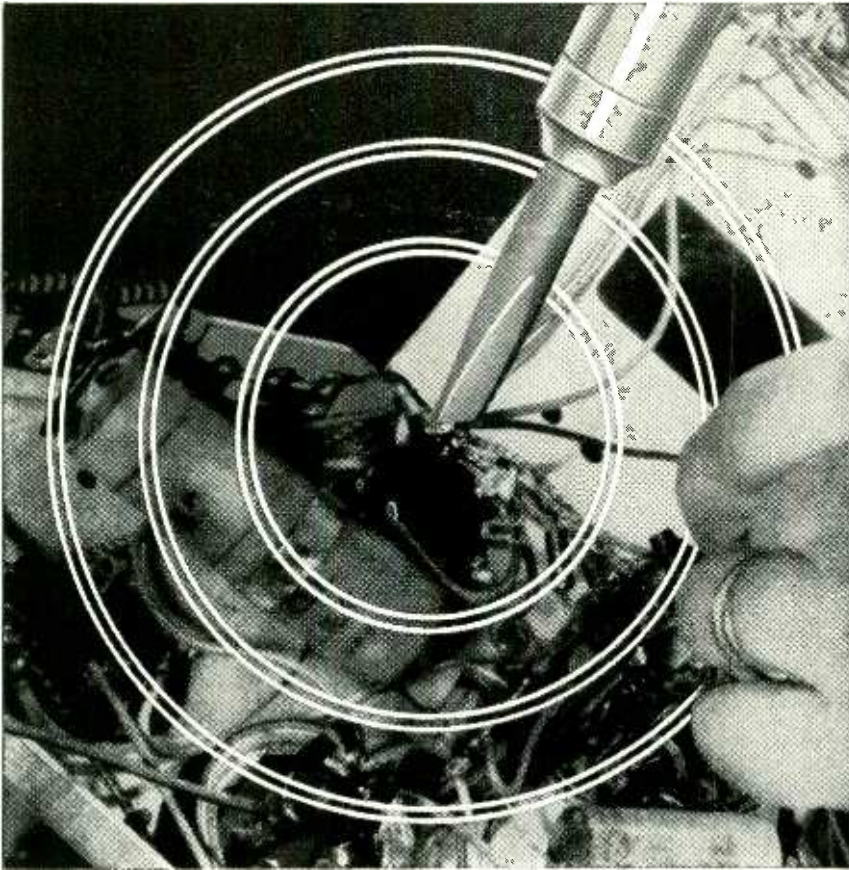

**You can't beat
a soldered connection
for electrical conductivity and permanence!**

SOLDERED connections eliminate loss of current, fire hazard, radio interference and excess heat which result from loose, corroded, arcing NON-SOLDERED connections.

For over 50 years experts have specified American Beauty Electric Soldering Irons. They know American Beauty Irons are built to LAST LONGER, OPERATE DEPENDABLY and BE SERVICED QUICKLY.

Build better with solder . . .
Solder better with
American Beauty
SOLDERING IRONS

WRITE FOR FREE LITERATURE

Dependable • Durable • Efficient
SINCE 1894

AMERICAN ELECTRICAL HEATER COMPANY
DETROIT 2, MICHIGAN A-100

BROADCAST GRID-DIP METER

Many of us associate the grid-dip oscillator only with alignment and checking of h.f., v.h.f., and u.h.f. transmitting and receiving circuits. Actually, this handy instrument is equally useful at frequencies in and below the broadcast band. This grid-dip oscillator covers a frequency range from approximately 510 to 1800 kc and is described here through the courtesy of the Cornell-Dubilier Electric Corporation.

The oscillator is a 6C4 in a series-fed Hartley circuit tuned by a 365- μ mf straight-line-frequency capacitor. Two 6.3-volt, 1-amp filament transformers connected back-to-back isolate the unit from the power line. L1 consists of 165 turns of No. 29 enameled wire wound on a 1-inch diameter polystyrene or low-loss bakelite form and tapped at the 55th turn from the ground end. L3 consists of 2 turns of No. 22 d.c.c. wire close-wound $\frac{1}{4}$ inch from the ground end of L1.

The 0C3 voltage-regulator tube helps maintain the necessary oscillator stability by holding the plate supply constant at 105 volts. It may be necessary to insert an adjustable 10K series resistor between the output end of the 1,200-ohm filter and pin 5 of the 0C3 to set the proper firing point, and limit the current through the regulator.

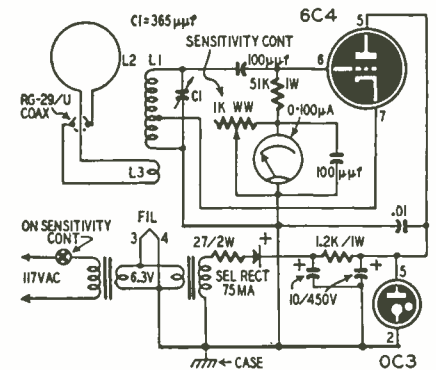

The pickup loop, L2, is a 2-inch diameter single turn of No. 12 insulated copper wire. It is mounted in one end of a length of $\frac{1}{2}$ -inch polystyrene tubing which serves as the handle. The pickup loop is connected to L3 through a 2-foot length of RG-29/U coaxial cable terminated in a RG-88/U male coax plug which fits into an RG-290/U socket on the panel. Other single-turn loops of larger and smaller diameters may be used for coupling to coils of different sizes. The only precaution is to make sure that the resonant frequency of L2 and the coax cable is well outside the broadcast band so it will not cause false indications.

A small sloping-front metal cabinet makes a convenient housing for the instrument and improves meter readability.

The instrument can be calibrated by beating its oscillator against broadcast stations picked up on a receiver. Begin at the low-frequency end of the band to prevent errors through accidental use of harmonics.

—end—

SW RECEIVER MODIFICATIONS

? I have an all-wave broadcast receiver that covers all frequencies from the low end of the broadcast band to 60 mc. This set has one stage of r.f. and is very sensitive. How can I improve the selectivity and tuning so it will be easier to use on the amateur bands? Can I add a b.f.o. to the set?—*E. S. K., Keyport, N. J.*

A. You can add electrical bandspread by connecting a small variable capacitor across the oscillator section of the main tuning gang and connecting this capacitor through a suitable shaft to a ver-

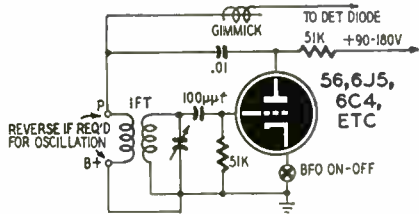

nier dial on the front panel. Better yet, use a three-section capacitor with one section connected in parallel with each section of the main tuning gang. This will improve tracking when using bandspread tuning. As an added refinement, you can connect a second variable capacitor across the antenna tuning section. This capacitor should be about 10 µf maximum and is used to peak the input stage.

The drawing shows a typical b.f.o. circuit. You can use an old i.f. transformer for the b.f.o. coils. It should have the same frequency as the i.f. of your set. You can also use a 4-pie 2.5-mh choke. Connect a tap between the third and fourth pies for the cathode or ground connection and shunt the three pies with enough capacitance—about 75 µf—to tune within a few kilocycles of the i.f.

Special transformers for b.f.o. circuits are supplied by several r.f. coil and transformer manufacturers. These are usually supplied with typical circuits.

For greater selectivity, we suggest that you add a Q-5'er having an i.f. of about 150 kilocycles or lower. Several surplus receivers can be used for this purpose. Their conversion has been covered in the various amateur publications.

ADMIRAL 21L1 TV SET

? My Admiral TV receiver has poor horizontal sync. The picture rolls horizontally frame by frame. In checking the components in the horizontal sync circuit, I found a VR54 tube which I believe to be the sync discriminator. I can't find any data on it and can't get a replacement. Removing this tube from the set has no effect on the performance. Can you explain the purpose of this tube and recommend a replacement?—*E. E., Bronx, N. Y.*

A. The VR54 is equivalent to the 6H6 and was used in a few Admiral chassis during a tube shortage. This tube is the sync discriminator and can be replaced by a 6H6.

Another  First...

3-Speed Record-Changer Phonomotor

new design
new simplicity
new low cost



• First with the belt-type 3-speed motor . . .
first with the turret-type 3-speed motor . . .
General Industries *again leads the field* with this novel 3-speed motor.

Developed for one of General Industries' good customers, and field proven over a period of time, this 3-speed motor as illustrated has a stepped shaft and shifting idler wheel arrangement. Model illustrated currently being supplied to well-known record-changer manufacturer, with special construction for customer's own application.



THE GENERAL INDUSTRIES CO.

Department ME • Elyria, Ohio

Over 43,000 Technicians Have Learned

HOW TO GET THE MOST OUT OF BASIC TEST EQUIPMENT

Why Not You, Too?

SERVICING by SIGNAL SUBSTITUTION

A BEST SELLER FOR OVER 9 YEARS! (NEW, UP-TO-DATE, 12TH EDITION)

The Simple, Modern, Dynamic Speed Approach To Receiver Adjustment and Alignment Problems, AM-FM-TV.

- Nothing complex to learn
- Universal — non-obsolete
- No extra equipment to purchase
- Employs Only Basic Test Equipment

only **40¢**

100 pages. Invaluable information that will help you re-double the value of your basic test equipment.

Ask for "S.S.S." at your local Radio Parts Jobber or order direct from factory.

PRECISION APPARATUS COMPANY, INC. • 82-27 Horace Harding Blvd., Elmhurst 4, N. Y.



Who Else Offers TV BARGAINS LIKE THESE?

Most Amazing ALL CHANNEL Antenna Known

Rocket DIRECTRONIC MOTORLESS TV ANTENNA

360° Electronically Switched Beam

- No Motors
- No Roof Orientation
- No Electric Power
- No Ghosts
- Flick of Switch Clears Picture Instantly

The Motorless Directronic Amazing 360° Reception Pattern Shown Below

AX-599 Directronic, as shown \$16.95

In the city or in an ultra-fringe area, the Directronic will out-perform ordinary antennas. Only the Motorless 360° Directronic TV Antenna offers around the compass reception WITHOUT Rotors. Clarity of picture will amaze. It's so bright, so sharply defined. Extremely durable construction assures long service. AX-599 "Service-man's Array" contains 11 fine coiled insulator of extremely high tensile strength, 18 1/2" tensile aluminum alloy elements, 1 set of connecting stubs (3), Universal U-Clamps for masts to 1 1/2" Directronic Beam Selector, 75 Feet of Tri-X Cable, 1 Stacked array per carton.

AX-59 Directronic 9 element Single \$10.35

WORLD'S GREATEST ULTRA FRINGE AREA ANTENNA

Rocket YAGI 8 Element TV Antenna Super Reception in Fringe Areas

This sensational Super Fringe Yagi Antenna out-performs all other types. Never before has an antenna produced such clear, sharp, steady pictures. Ghosts and interference are kept to a minimum due to the directive single channel pattern. Maximum signal strength is obtained. Exclusive construction assures trouble-free operation even in worst weather. Pre-assembled for quick re-installation. Just swing elements into position and tighten wing nuts. Exclusive design mast clamp prevents antenna turning or canting under any conditions. Has coiled insulator for greatest strength. 8 elements include 6 directors, one folded dipole, one reflector. Matches 300 ohm impedance. Supplied less mast.

Channels 2 or 3 \$15.95 Channels 4, 5 or 6 \$12.95 Channels 7 to 13... \$7.95

Economize with Famous Rocket 5 ELEMENT YAGI Antennas

For Fringe Areas 50-65 miles from transmitter. Same super hi-gain construction as 8 element Rocket Yagi.

Channels 2 or 3 \$7.95 each Channels 4, 5 or 6 \$5.95 each 7 to 13 \$3.95 each

EACH CHANNEL requires a DIFFERENT Yagi. When Ordering specify exact channel number desired.

ALL CHANNEL CONICALS

Single Bay \$3.35 Stacked Array with Tie Rods \$7.40

LOWEST PRICES ON TV ACCESSORIES

Mast Steel (Dualcoated 5' Crimped) 1 1/4" O.D.	\$1.05
Mast Steel (Dualcoated 10') 1 1/4" O.D.	1.95
Mast Steel (Zinc Plated 10') 1 1/4" O.D.	1.50
Mast Connectors for 1 1/4" O.D. Mast—10"	.49
Chimney Mount Complete with Straps	1.14
Peak Roof Saddle (will take up to 1 1/2" O.D.)	1.49
Lightning Arrestor—TV	.69
Galvanized Guy Wire—6 strand 20	3.47 ft.
Galvanized Guy Wire—14 strand 20	11.92 ft.
Aluminum Guy Wire, 300 ft. Reel	\$4.95
Tri-X 3 Conductor Lead-in	4 ft.
300 ohm Twin Lead 7/22 Stranded (500' Reel)	2.12
300 ohm Open Line Twin Lead—100' Reel	\$22.50
300 ohm Low Loss Twin Lead, 100mH Stranded	4.42 ft.
Mast Stand-off Insulators—3"	8.50 ct.
Stand-off Screw Insulators—3"	2.75 ct.
Stand-off Screw Insulators—7"	3.50 ct.

Rocket Products sold only by mail by National Electronics

Prices Subject to Change Without Notice

ALL PRICES F.O.B. CLEVELAND, OHIO

Do not remit more than complete purchase price. Pay shipping charges on receipt of goods. 25% deposit on C.O.D. orders, please. Money-back guarantee.

FREE CATALOG OF BARGAINS AVAILABLE

National Electronics OF CLEVELAND THE HOUSE OF TV VALUES

209 DeLoz Building, Cleveland 3, Ohio

U.H.F. RHOMBIC FOR TV

? I want to construct a 3-wire rhombic antenna for u.h.f. TV channels 16 and 22. I would like the antenna to have as much gain as possible without exceeding 10 feet in length. Can you prepare a diagram of such an antenna? —R. C., Carbondale, Penna.

A. If a rhombic is designed to operate with maximum gain over a wide range of frequencies, it should have as many wavelengths (at the lowest frequency) as possible in each leg. Therefore, it should be cut for the low-frequency end of channel 16 (492 mc). One wavelength in inches equals 11,800 divided by the frequency in megacycles. At channel 16,

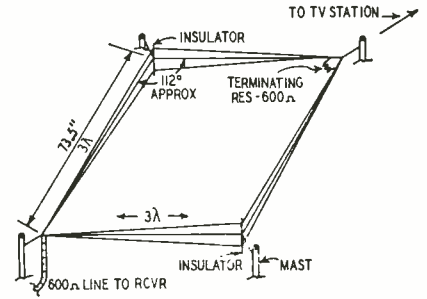

one wavelength equals approximately 24.5 inches. Since the length of the rhombic is limited to 10 feet, you can use three wavelengths in each leg with an angle of approximately 112 degrees between adjacent legs of each side as shown in the diagram.

The construction of a three-wire rhombic is similar to that of a single-wire rhombic. However, each leg consists of three wires joined together at the ends and separating gradually as the junction of the legs is neared. At the side supports, the wires should be approximately 3 inches apart. Since all the wires are the same length, the two outside ones will be slightly farther from the supporting mast than the center ones.

The sharpness and the elevation of the major lobe are determined by the height of the antenna above ground and the included angle between adjacent legs at the sides. Raise and lower the terminated end of the antenna to determine the angle at which signal strength is maximum.

The 3-wire rhombic has an impedance of approximately 600 ohms so you should feed it with a 600-ohm open-wire line. A one-quarter wavelength matching section should be used to reduce the impedance to match the input of the receiver.

Although the diagram shows supporting masts, you can use crossed booms on a single mast.

AUTO RECEIVER CONVERSION

? I would like to obtain directions for receiving 1714-kc signals on my Silver-tone auto radio (chassis 528.6295-4). If a converter is required, it should take the necessary operating voltages from the receiver.—Wm. C. P., Waialua, Oahu, T. H.

A. The simplest method of receiving

STAN-BURN SPARKS

- * ANTENNAE SPECIALS ***
- * CIRCLE X Limited Quantities \$2.98 each
 - * DOUBLE V 3/8" \$2.98 \$2.20
 - * DOUBLE V 3/8" Dowel 3.45 2.45
 - * DOUBLE V 1/2" Dowel 3.95 2.95
 - * 10 Element Conical 3/8" 3.55 2.55
 - * Rig 1/2" elements 4.25 3.25
 - * WINDOW CONICALS 4.95 3.75
 - * 5 FOOT SWEDGED MASTS .79 .69
 - * 10 FOOT PLAIN TWIN WIRE 1.39 1.29
 - * 55 Mil. 300 OHM \$14.95 M.Ft.
 - * 72 OHM COAXIAL 45.00 M.Ft.

- CATHODE RAY TUBE SPECIALS**
- STANDARD BRANDS—UNCONDITIONALLY GUARANTEED
- * 10BP4A Sheldon 24.00 Federal 23.00
 - * 10BP4A N.U. 18.95 19AP4A Sheldon 29.95
 - * 12LP4 Sheldon 18.95 19AP4A GE 38.00
 - * 12LP4A Thomas 19.95 19AP4A Thomas 39.95
 - * 16AP4 Sheldon 24.00 19DP4A Sheldon 29.95
 - * 16AP4A GE 34.20 20CP4A Dumont 37.00
 - * 16DP4A Thomas 28.50 20CP4A Sheldon 31.00
 - * 1 D-HP4A Sheldon 24.00 21EP4A Federal 29.00
 - * 16GP4 Sheldon 24.00 1EP4A Dumont 39.00
 - * 16GP4A Sheldon 30.25 24AP4A Sheldon 63.00
 - * 16JP4A Sheldon 24.00 24AP4A GE 68.40
 - * 16RP4A GE & NU 23.40 Single ion traps .39
 - * 16XP4A Sheldon 24.00 Double ion traps .59
 - * CHASSIS 630 REGAL with Cascade Tuner \$139.50
 - * 211 T3 FLY BACK (Similar to RCA) 2.98
 - * OPEN FACE CABINET 39.00

- TRANSFORMERS**
- * RCA type for 16" to 24" X032A \$3.85
 - * G.E. Type for 16" to 24" X045 3.85
- These are very special prices while they last!
- DEFLECTION YOKES**
- * Cosine Ferrite Todd Yoke 70" \$4.20
- SPECIALS**
- * 4 Prong Vibrators, each \$1.29
 - * Lots of 12 or more \$1.19
 - * Standard TV Tuners \$18.95
 - * 12" Heavy Slug Speaker Special 4.98

- * Audio Devices, Discs, and Scotch Tape In Stock**
- * Audio Plastic Record Player \$2.30
 - * Half hour spool \$2.30
 - * One hour spool \$3.30
- WIRE RECORDERS IN STOCK**
- * WILCOX GAY—Model 2A10 \$89.97
 - * PENTRON—Model 973C—2 spd. Tape Recorder \$34.50
 - * RADIO Model RC2-HIFI Amplifier .net 42.89
 - * CRAFTS Model RC10—AM-FM Tuner .net 130.84
 - * MEN Model C5—Whitman Amplifier .net 99.45
 - * ASCODE Guaranteed Tuners (with tubes) Special, while they last \$21.95
- AUTHORIZED DISTRIBUTORS for:** General Electric, Kenrad, Tung-Sol, National Union, Jewel, De Wald, Regal, Automatic and Setchel Carlson.
- We carry a complete line of popular makes of radio and TV tubes, at 50% discount. Also many other special purpose and transmitting types, and all electronic parts and equipment at lowest prices.
- Send us a list of your requirements for prompt quotations. Terms: 20% with order. Balance C.O.D. All prices F.O.B. New York Warehouse. Minimum order \$5.00
- * Write for our latest price list to Dept. RE-9 ***

STAN-BURN RADIO and ELECTRONICS CO.

(C.B.S. THEATRE BLDG.)

1697 BROADWAY • NEW YORK 19, N.Y.

Another Outstanding Jobber

M. SCHWARTZ & SON

710-12 BROADWAY SCHENECTADY, N.Y.

EICO has all TV KITS & INSTRUMENTS in stock!

See EICO ad on Page 20

Please Mention

RADIO ELECTRONICS

When writing advertisers

RADIO-ELECTRONICS

1714-kc signals on your set is to switch in pretuned antenna and r.f. coils as shown in the diagram. This will give you reception by the image method, without alterations to the receiver oscillator circuit. Your receiver has a 262-kc i.f., with the oscillator tuned 262 kc above the frequency shown on the dial. With the receiver dial set at 1190, the oscillator will be tuned to 1452 kc, which is exactly 262 kc below the desired signal frequency.

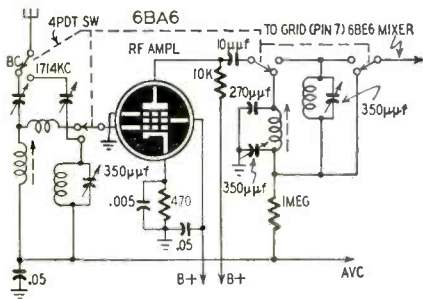

Miniature antenna and r.f. coils which tune to 1714 kc should be used. The coils and switch should be located close to the mixer and r.f. amplifier tubes. A small bracket or apron on the rear of the chassis will probably provide ample space for the added components. The switch can be controlled through a long flexible shaft.

For other frequencies a few kilocycles removed from 1714 kc, the receiver dial setting may be found by subtracting twice the receiver's i.f. from the desired signal frequency.

Men who know *Quality* .. know **TECH-MASTER**



C. G. McPROUD,
Editor of **AUDIO**
Engineering, writes:

"I assembled my own home TV receiver from a standard Techmaster kit. I was amazed at the speed and simplicity with which this could be done. So gratifying was the result, that I have since

been obliged to assemble several more Techmaster receivers for friends who marvelled at the picture quality of my own. In each case the results were excellent and have provided their owners with uninterrupted top quality, trouble-free performance..."

More leading engineers and technicians have chosen Techmaster Kits and Techmaster Chassis, than any other television.

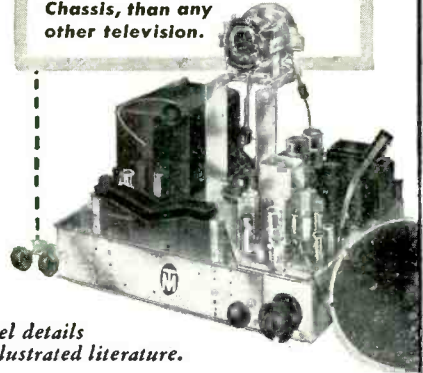

Experts Everywhere Concede the Superiority of the Techmaster 630 Type Circuit!

The TECHMASTER 630 has been advanced in every detail of modern engineering and design. Every component is the best available, and rigid factory and test standards are your assurance of years of trouble-free performance. Prefabricated unit construction, factory pre-adjusted and pre-aligned make assembly an utterly simple and enjoyable procedure with a minimum of tools.



See your local Jobber for model details or write direct to factory for illustrated literature.

TECH-MASTER PRODUCTS COMPANY • 443-445 BROADWAY, N. Y. 13, N. Y.

Get This Valuable Book

Just for Examining COYNE'S New 6-Volume Set

FREE



Applied Practical Radio-Television

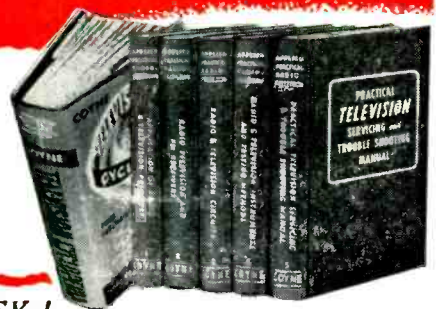

ON 7 DAY FREE TRIAL!

Yes, you get this big, brand new book, "150 Radio-Television Picture Patterns and Diagrams Explained", absolutely FREE! Just off the press! Gives complete wiring circuits and diagrams on the latest Radio and Television Sets. Easy-to-read, large 8½ x 11" pages, with full instructions on how to read and use the diagrams. A "must" in every Radio and Television service-man's repair kit. You get this valuable book as a FREE Gift for asking to see Coyne's great new 6-book set, "Applied Practical Radio-Television"!

Here's "Know-How" That Makes You Worth More!

You'll get into the big money faster in TELEVISION-RADIO if you know where to find the answer to servicing problems. Coyne's great new 6-volume set gives you all the answers—quickly! For basic "know-how" that is easy to understand, you'll find everything you want in volumes 1 to 5 which contain over 5000 practical facts and data. They cover every step from principles to installing, servicing, trouble-shooting and aligning all types of radio and TV sets. So up-to-date it includes COLOR TV and UHF. adaptors and converters.

762-Page Television Cyclopedia Included

And then, for speedy on-the-job use, you get volume 6—the famous Coyne TELEVISION CYCLOPEDIA. It answers today's television problems on servicing, alignment, installation and others. In easy-to-find ABC order, cross indexed. Use this 6 volume TV-RADIO LIBRARY free for 7 days; get the valuable Servicing Book ABSOLUTELY FREE!

SEND NO MONEY!

Just mail coupon for 6-volume set on 7 days free trial. We'll include book of 150 TV-Radio Patterns & Diagrams. If you keep the set, pay \$3 in 7 days and \$3 per month until \$23.00 plus postage is paid. (Cash price \$22.00). Or you can return the library at our expense in 7 days and owe nothing. **YOU BE THE JUDGE.** Either way, the book of TV-Radio Patterns is yours FREE to keep! Offer is limited. Act NOW!

FREE BOOK—FREE TRIAL COUPON!

COYNE ELECTRICAL & TELEVISION-RADIO SCHOOL, Dept. 92-T1
500 S. Paulina St., Chicago 12, Ill.

YES! Send 6-volume "Applied Practical Radio-Television" for 7 days FREE TRIAL per your offer. Include TV-Radio Patterns & Diagram Book FREE.

Name..... Age.....

Address.....

City..... Zone.... State.....

Where Employed.....

() Check here if you want library sent COD. You pay postman \$22 plus COD postage on delivery. 7-day money-back guarantee.

COYNE ELECTRICAL & TELEVISION-RADIO SCHOOL
500 S. Paulina St., Dept. 92-T1 Chicago 12, Ill.



Ask your distributor for your Taco Cat. No. 38 — the Antenna Handbook.

TACO TECHNICAL APPLIANCE CORPORATION
 Sherburne, N. Y.
 In Canada: Stromberg-Carlson Co., Ltd., Toronto 4, Ont.



STEVE-EL Television sets work where others fail because they are built of the finest materials and designed by top electronic engineers. Standard COIL CASCADE TUNER makes them perfect for fringe area reception.

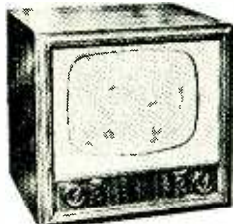

Manufactured under license by RCA. RMA Guarantee on all parts and ONE FULL YEAR guarantee on picture tube.

Features:

- Standard coil Cascade tuner. • Large HI-FI speaker. • Hand rubbed, satin finished genuine mahogany cabinet. • AGC. • Moulded condensers. • Picture tube. • Adaptable for UHF and color. • Synchronized FM audio system. • Factory wired, aligned and tested. • Mounted in cabinet.



17" ... \$162.
 20" ... \$186. 21" ... \$204.
 24" ... \$287.

17" ... \$148 20" ... \$174

Extra Special

Webcor Tape Recorder
 Model 210... **\$137.50**

Pentron Tape Recorder
 Model 9T-3C... **\$117.50**

Microphones at 50% off list
 Shure-Turner, etc.

Write for list

Send for Latest Catalog

STANDARD BRAND TUBES									
(Manufactures of tubes refuses permission to mention name because tubes are FAR BELOW FAIR TRADE)									
1A7	.89	6AG5	.79	6CB6	.71	6X5	.62	12SQ7	.60
1B3	.89	6AH6	.79	6CD6	2.37	7D5	.74	14A7	.64
1H5	.71	6AK5	1.29	6IS	.54	7F7	.74	18BE	.94
1N5	.74	6AL5	.68	6J6	.66	7K7	1.09	21BQ6	.64
1S3	.79	6AQ5	.59	6K6	.66	7N7	.84	25L6	1.29
174	.79	6AT6	.68	6K7	.74	12AT6	.65	25W4	.64
1U5	.78	6BA6	.69	6SA7	.64	12AT7	.65	25Z6	.67
1X2A	.94	6BC5	.74	6S17	.64	12A U7	.66	35L6	.66
3Q1	.89	6BE6	.79	6SK7	.74	12A V7	1.19	35W4	.66
3Q3	.89	6BG6	1.76	6SL7	.72	12A X7	.99	35Z5	.62
3U4	.73	6BH6	.88	6SN7	.74	12BA6	.69	50A5	.66
3U4	.63	6BK7	1.15	6SQ7	.64	12BE6	.69	50B5	.66
5V4	.47	6BQ7	1.15	6V6GT	.64	12BH7	.99	50C5	.66
6AC7	.94	6C4	.54	6W4	.64	12SK7	.72	50L6	.66
						12SN7	.84	117Z3	.64

Above partial listing only. Send for complete list

STEVE-EL ELECTRONICS CORP.

VISIT OUR NEW STORE

Dept. E-9 61 Reade St., New York 7, N. Y. COrtlandt 7-0086

AIR-COUPLER DESIGN

? I have heard a lot about the good low-frequency response that can be obtained from inexpensive speakers in air-coupler types of enclosures. Please print constructional details on this type of unit and tell me where I can find additional references on the subject.—
 A. C. D., Detroit, Mich.

A. The drawing shows the air coupler described by the late Edmund T. Flewelling in the November, 1950, issue of *Audio Engineering*. The unit is constructed from boards or plywood at least three-quarters of an inch thick with a liberal application of wood screws. Note well that the speaker is mounted *outside* the rear wall of the column and that the rectangular port is the only opening in the front wall of the coupler.

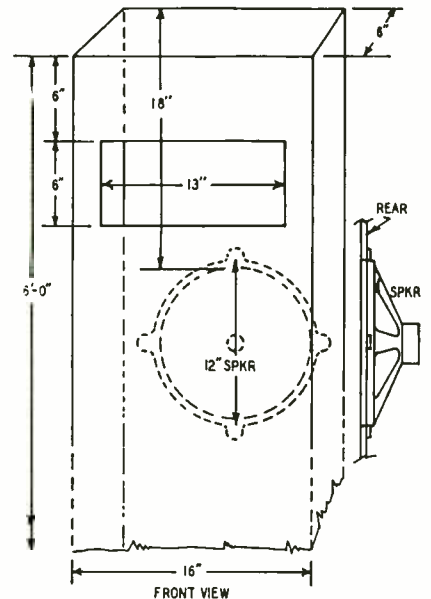

The air coupler may be installed so it stands on one end, or you may lay it on its side and build it into a bookcase or any similar enclosure. Some hi-fi fans have installed them between the studs in the wall of the room. Others have built them into the space between the joists in the floor or ceiling. In either case, the port is the only opening into the room.

Several experimenters have worked out interesting variations and improvements on the air coupler. The modifications include dividing the coupler into two air columns of different lengths to smooth out the response at the lower frequencies and adding a reflex arrangement and a second port to provide sound reinforcement from the rear of the speaker. These variations and improvements were described in *Radio Communication* for October, November, and December, 1950; February, October, and December, 1951; and February, 1952; and in the winter edition (Vol. 1, No. 3) of *High-Fidelity*.

The speaker itself must be rugged and have good low-frequency response. Some form of frequency-dividing network must be used to feed only the desired lows to the air-coupler unit.

—end—

ENGINEERS

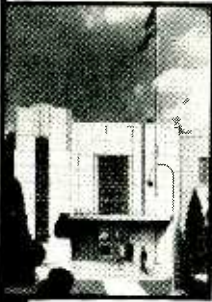

Make this your home for important work under ideal conditions

- TV Receiver Design Eng.
- Test & Inspection Eng.
- Electronics Eng.
- Field Engineers
- Lab Technicians

TO WORK ON:

Radar, G. C. A., Mobile Radio, Auto Radio, Airborne Communication & Navigation Equipment, Television, Antennas, Microwave Equipment, Servo Mechanisms, Guided Missiles and Test Equipment.

YOU BENEFIT

from high wages, a modern, air-conditioned plant, paid vacations and holidays, group insurance and a good chance for advancement. Housing immediately available in the beautiful suburban and country areas that surround the Bendix plant.

Write Wire, Phone Mr. E. O. Cale, Dept. S

Bendix Radio

DIVISION OF BENDIX AVIATION CORP.

BALTIMORE-4, MD.

Makers of the World's Finest Electronic Equipment

RADIO-ELECTRONICS is paying good rates on acceptance for original and unusual articles on phonograph, television, FM and AM servicing, as well as articles on industrial electronic equipment and applications. Good constructional stories on receivers or other pieces of electronic equipment can also be used. Send for a copy of our Author's Guide. Address:

THE EDITOR
RADIO-ELECTRONICS
25 West Broadway
New York 7, N. Y.

RE: ARCING IN DEWALD SET

In the "TV Service Clinic" of the May, 1952, issue, a reader inquired as to the cause of arcing at the grounding springs on a DeWald receiver. The conditions explained by Mr. Mandl may exist, but a leaky high-voltage filter capacitor is by far the most common cause of this trouble. It is a common occurrence in the Admiral 21B1 and similar chassis.—*Robert Brown*

STABILIZING THE PILOTUNER

In the *Pilotuner* the 3-gang aluminum capacitor body is grounded by mechanical contact to the aluminum chassis in a bolted connection.

I have found that a low-resistance electrical connection from capacitor to chassis greatly improves performance and controls any tendency toward oscillation at the high end of the FM band.

This connection can be made by soldering copper braid from the r.f. coil connection at the rear, right end of the capacitor body to a tube socket rivet in the chassis.

The copper braid can be stripped from shielded cable if none is available, and about two inches will do the trick. The braid may be stiffened by tinning it beforehand.—*Howard Warriner*

KEY CLICKS ON HT-17

A fellow ham brought his HT-17 rig into the shack and asked my help in licking a bad case of key clicks. We tried the usual choke and capacitor combinations in the various well-known key-click filter circuits. All of these seemed to make conditions worse rather than better. Finally, we found the circuit and values that did the trick. We connected a 20-henry choke in one of the keying leads and a 0.5- μ f, 600-volt capacitor *directly* across the key terminals. These values are exact for this particular rig. Substituting slightly different ones for either component will let the clicks come through as strong as ever.—*Gerald Samkofsky, W2YSF*

(The author mentioned that he is now trying to clean up severe TVI which occurs when the rig is used on 11-meter c.w. He would appreciate complete details from anyone who has licked the TVI problem on this rig.—*Editor*)

TENNA-TOP BOOSTER

When using the Electro-Voice Tenna-Top booster with the Du Mont RA-119-A receiver, shunt the relay in the junction box with a resistance of 0.1 to 0.2 ohms to prevent burnout. This resistance can be made up from five 1-ohm, 1-watt resistors connected in parallel. The present relay in the booster is designed to operate with receivers using a maximum of 500 watts. The RA-119-A draws 650 watts.—*Du Mont Service News*

VR PICKUP CARTRIDGES

It has been found that open circuits in G-E variable-reluctance cartridges are usually caused by soldering the phono leads directly to the cartridge terminals. Excess heat produced during soldering burns the fine wire to the pickup coil and causes it to open. *Always* solder the phono leads to the push-on terminals supplied with the cartridge.—*G-E Radio Service Bulletin*

LET THESE Professional SERVICE METHODS Boost Your Earning Power!



Ghirardi's new 1-vol. training course helps you handle jobs more efficiently—in less time!

COMPLETELY NEW!

Radio and TV Receiver TROUBLESHOOTING AND REPAIR

820 pages, 417 illustrations, \$6.75

For the beginner, this NEW Ghirardi book is a complete up-to-the minute guide in servicing by modern professional methods. For the experienced servicemen, it is a quick way to "brush up" on specific types of work, to develop improved techniques or to find fast answers to puzzling problems.

Components, their troubles, their replacement and even their repair are fully analyzed. Modern testing methods including both "static" and "dynamic" tests using signal tracing and injection techniques are carefully explained. You learn how to set up an efficient service procedure and to interpret data fast and accurately. Four big chapters show how to handle TV, FM and AM realignment jobs in less time and with a minimum of equipment. Unique "step-by-step" charts explain complicated servicing details almost at a glance.



LICENSE EXAMS WON'T "STUMP" YOU!

This is the ideal book to help you pass servicing licensing examinations now pending in many places.

Remember: Ghirardi books are more widely used for school, military and home study training than any others of their type! This new book is the latest, most helpful of all for boosting your service profits!

THE HOW-TO-DO-IT GUIDE TO M-o-d-e-r-n SERVICE METHODS!

Nowhere else will you find troubleshooting procedure and servicing operations explained so clearly or so understandably! Dozens of service "tips" are equally helpful. You learn to analyze many television troubles without laborious testing. You learn what to do about those puzzling intermittent troubles; how to service difficult 3-way portable filament circuits; how to handle ac/dc and transformerless power supply heaters *professionally*; how to remedy fading and propagation troubles . . . and many more.

No really practical service procedure has been omitted—and all are explained so clearly you can't fail to understand them! Use coupon!

MAIL ORDER! 10-DAY EXAMINATION

Dept. RE-92, RINEHART BOOKS, INC. Technical Division 232 Madison Avenue, New York 16, N. Y. Send Ghirardi's new Radio & TV Receiver TROUBLESHOOTING AND REPAIR for 10-day examination. If book is what I want, I will then promptly remit \$6.75 plus a few cents postage or return book to you postpaid.

Name

Address

City....., Zone....., State.....

Employers' name & address.....
OUTSIDE U.S.A.—Price \$7.25, cash only.
Same 10-day return privilege with money refunded.

The "DO-ALL" 3

COMPLETELY SERVICES TV!

A unique and revolutionary set of economical and compact testing instruments for TV Servicemen

RCP
MODEL
533M

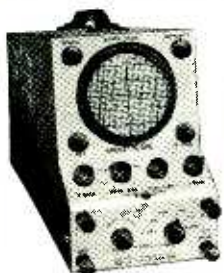

MIDGETSCOPE

Weights only 9 pounds!
Size: 11 3/4" x 7 3/4" x 5 1/4"

This 3" scope packs a high sensitivity, wide band response instrument within its tiny lightweight frame.
SENSITIVITY: Vertical—20 millivolts
FREQUENCY RESPONSE: 20 cycles to 150 Kc
In metal case with leather handle—Etched panel—Smart brushed aluminum face—Fuse protected—for 105-125 V, 60 cy. AC operation.

Model 533M—Complete, ready to operate. **\$99.50 net**

RCP
MODEL
808

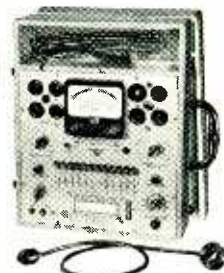

TV SET and TUBE TESTER

(Includes VT VOLTMETER and Reactivator)
All in ONE unit

- A TUBE TESTER
- A CATHODE RAY TUBE TESTER
- A CATHODE RAY TUBE REACTIVATOR
- A VACUUM TUBE VOLTMETER (AC-DC)
- AN OHMMETER

In hand-rubbed oak carrying case with test leads, isolation probe, batteries, etc. Size: 12 1/2" x 12 3/4" x 4 3/4" Wt. 12 1/2 lbs.

Model 808—Complete, ready to operate **\$99.95 net**

High Voltage Multiplier Probe for Model 808
Extends range of VTVM to 30,000 volts.

Model HVMP-1 **\$8.95 net**

RCP
MODEL
740

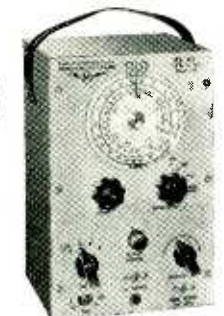

TV "DO-ALL" GENERATOR

HERE—AT LAST! One compact efficient instrument—which gives the performance of several combined instruments—each of which is higher priced and all of which are needed for properly servicing TV and FM receivers.

It's a...SIGNAL GENERATOR
It's an...AUDIO GENERATOR
It's a...MARKER GENERATOR
It's a...PATTERN GENERATOR

RANGE: 9 megacycles to 220 megacycles all on fundamentals—bands 9-11 meg; 21-47 meg; 53-220 meg.

Unusually fine circuit design—new brushed aluminum face, etched panel and dial.
Size: 10"x6"x6". Wt. 8 lbs.

Model 740 Complete, with output cable, ready to operate **\$69.50 net**

Write today for the latest RCP catalog to Dept RE-9

RADIO CITY PRODUCTS CO., INC.

152 WEST 25th ST.—NEW YORK 1, N. Y.

TUBES 50¢

A REPEAT OFFER

5U4G 6AU6 6AL5 6BQ6

ALL AMERICAN SERIES—\$2.50

12SA7 12SK7 12SQ7 35Z5 50L6

Our Flyer contains a terrific FREE BONUS—

Send for your copy today

THIS MONTH'S SPECIAL

No. 807—2 for \$2.50

CROWN TELEVISION

P. O. Box 194

Hicksville, N. Y.

Please Mention
RADIO-ELECTRONICS
When Writing
to Advertisers

RADIO-ELECTRONICS is paying good rates on acceptance for original and unusual articles on phonograph, television, FM and AM servicing, as well as articles on industrial electronic equipment and applications. Good constructional stories on receivers or other pieces of electronic equipment can also be used. Send for a copy of our Authors' Guide.

Address:

THE EDITOR

RADIO-ELECTRONICS 25 West Broadway, New York 7, N. Y.

MODIFYING THE WR-59A

The RCA WR-59A TV sweep generator does not provide a 40-50-mc signal for aligning the i.f.'s of TV sets having intermediate frequencies in this range. However, this instrument can be modified to provide 41.25- and 47.25-mc signals at the r.f. output cable.

Interchange the coil core for the A band (10-11.5 mc) with the coil core for channel 1 (44-50 mc). The location of these cores is shown in the drawing. After interchanging the cores, adjust the core in the channel 1 coil to provide the correct center frequency. Proceed as follows:

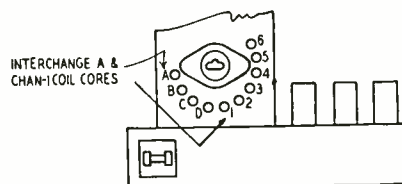

1. Connect an oscilloscope to the video detector output of a properly-aligned operating receiver with a 45-mc i.f. channel.

2. Connect the r.f. output cable to the receiver's i.f. input.

3. Note the response curve on the scope and adjust the channel 1 core to get the desired frequency range.

4. Check the limits of the response curve with a TV calibrator or accurate marker generator.

The channel 1 position will now provide enough signal to align receivers having 45-mc i.f.'s. Note that this signal is available at the r.f. output cable and is controlled by the r.f. attenuator.—Montgomery Ward's General Service Letter

TELE-TONE MODEL 249

We have had a number of these sets brought into the shop with the complaint that picture height has reduced to only 2 or 3 inches. Although there are a number of possible causes for this difficulty, nine times out of ten we are able to locate the trouble in the height-control circuit. The 1.5-megohm resistor in series with the height control may have reduced to as low as 500,000 ohms or it may have opened up. In either case, replace the fixed resistor with a 1.5-megohm, 1-watt unit.—Martin Rosenberg

OLYMPIC 700 SERIES

Line-voltage surges often blow the fuse in the horizontal output circuit. This causes a small picture with fold-over on both sides and visible damping bars. To eliminate this condition: Remove the fuse from the present circuit and then remove the GREEN lead from terminal 1 of the horizontal output transformer and connect it to terminal 8. Connect the fuse between terminals 1 and 8. Remove the YELLOW lead from terminal 8 and reconnect it to terminal 7. Dress the fuse away from the high-voltage terminal and components.—Olympic Television Service Bulletin

RADIO-ELECTRONICS

RCA J2 RECORD CHANGER

When these changers continue to reject records or reject more than one at a time, the trouble can usually be traced to the cycling cam—a heart-shaped rubber-tired cam which operates the change mechanism. A small half-moon section of rubber has been removed from the cam to disengage the drive mechanism at end of change cycle.

The trouble occurs when the half-moon depression is too short. The inertia of the mechanism will cause the cam to coast across the space and re-engage the drive mechanism. The trouble is easily eliminated by elongating the cut-out section with a razor blade or a small hand grinder. Make the cut in the direction which will cause the drive to disengage sooner. Don't try to change the point at which it engages as this is controlled by the player mechanism.—*Joseph C. Burke*

SPARTON AM-FM CHASSIS

A few cases of AM drift have been reported on radio chassis types 6S10, 8L9, 8L10, 8M10, and 8S10. The cause was an incorrect value of grid resistor in the 6BE6 AM oscillator circuit. The correct value of this resistor is 22,000 ohms. Replace with a 1/2-watt unit if its value is incorrect.—*Sparton Service Division Bulletin*

20CP4 PICTURE TUBES

Underwriters' Laboratories requirements limit the maximum allowable capacitance between inner and outer conductive coatings of a TV picture tube to 250 μmf if a filter capacitor is used and to 750 μmf without a capacitor. This limits the outer aquadag band to a maximum width of 3 inches starting from the reference line. This narrow band does not provide sufficient radiation shielding, so it has been deleted from 20CP4's made by Hytron.

The exterior coating on Hytron 20CP4's is not the usual conductive coating. Instead, it is an insulating paint applied to improve the appearance of the tube.—*Hytron Engineering News Release*

MECK 16-INCH MODELS

Failure of the 0.25-μf, 600-volt capacitor connected to the damper tube cathode and the horizontal-linearity control coil is a common complaint on some of these models. This capacitor is mounted close to the 6,000-ohm, 20-watt resistor connected between plate and cathode of the 6W4-GT. Heat from the resistor melts the capacitor's insulation and causes it to fail. Premature breakdowns can be avoided by moving the replacement capacitor to a spot where it will not be affected by heat from the resistor.—*Yuki Minaga*

G-E MODELS 610 AND 611

Always leave the A-battery in place in the cabinet, even if it is not connected to the circuit. The reason for this is that the loop is tuned with the battery in place. Removing the battery detunes the circuit and reduces the sensitivity of the set.—*G-E Radio Service Bulletin*

—end—

SEPTEMBER, 1952

L. A. Gary
A Miniature Radio Buzzer, by Harold Lewis

SEPTEMBER, 1952

**MATTISON SILVER ROCKET
630 CHASSIS WITH TUNEABLE
BUILT-IN BOOSTER FOR BETTER
DX RECEPTION**

Featuring NEW CASCODE TUNER
made for UHF interchangeable
tuning strips and 70° COSINE YOKE

● Broad band single knob control pre-amplifier built in to eliminate long leads which may cause regeneration and attenuation of signal.

● ONLY THE MATTISON 630 CHASSIS HAS ALL CHANNEL TUNEABLE BUILT-IN BOOSTER THAT INCREASES SIGNAL STRENGTH UP TO 10 TIMES. THE SILVER ROCKET WILL OUTPERFORM ANY CHASSIS MADE—IS PRICED RIGHT TO SELL FAST WITH AN EXTRAORDINARY MARGIN OF PROFIT FOR YOU. WRITE FOR CONFIDENTIAL PRICE SCHEDULE

● Mattison features a complete line of cabinets MADE IN MATTISON'S OWN CABINET FACTORY. 36 breathtaking designs that blend perfectly in any setting, traditional or modern.

Tube Complement:
28 tubes
3 rectifiers
1 CRT
—
32

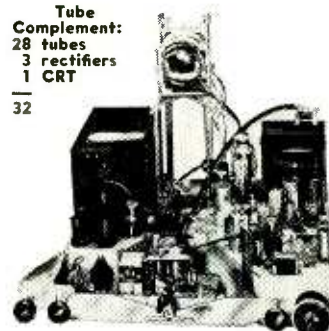

All Channel Booster

Here are some unsolicited, sincere reactions to the MATTISON TV LINE!

From Ashland, Ohio

"—only one word could describe it—TERRIFIC!

signed H. E. B.

From Tigard, Oregon

"—Yours is the best picture that I have seen of all custom sets. It brought in a picture from Seattle just like a picture from any local station that I have seen in the east last winter!"

signed G. E. B.

From Throop, Pa.

"—I am in a section where reception is poor, and I am the only one to get the above channels!"

signed J. A. H.

From Peru, Illinois

"—Your Silver Rocket Chassis is one of the finest chassis on the market today!"

signed G. A. B.

From Crossville, Tennessee

"—As for performance, both your chassis were outstanding. Everybody who has watched them concedes that they are the hottest things on the market. In the few days we used it in my home we got almost incredible results. They produce a remarkably good picture."

signed J. M.

DEALERS! SERVICE-DEALERS! Here is YOUR opportunity to become the "important" TV Dealer in your area for THE FINEST CUSTOM-BUILT LINE OF TELEVISION RECEIVERS. FREE! Write for Mattison's merchandising portfolio explaining "THE MATTISON UNASSEMBLED PLAN" and "THE MATTISON \$1,000,000 FLOOR PLAN". **SALESMAN — AGENTS!** Choice territories available. Become a Factory Sales Representative. Prefer men with experience selling direct to dealers. WRITE TODAY!



When you buy from Mattison you need only one source of supply! You can buy a Mattison Chassis, a Mattison Cabinet or a complete Mattison TV Set!

Mattison Television & Radio Corporation

893 Broadway, Dept. SD8 New York 3, N. Y.

TELEVISION

Big demand for graduates

B.S. DEGREE IN 27 MONTHS in radio including TV engineering—VHF, UHF, AM and FM. Students use over \$100,000 worth of equipment including 2 large commercial type transmitters in new TV lab. Intense specialized course includes strong basis in mathematics, science and advanced design in radio and TV.

Hundreds of young men each year are earning engineering degrees in this recognized institution. Start any quarter. Many earn a major part of expenses in this industrial center. Low tuition. Competent instruction. Thorough, intense, practical program.

Also B.S. DEGREE IN 27 MO. in Aeronautical, Chemical, Civil, Electrical and Mechanical Engineering. G.I. Gov't approved. Enter Sept. Dec., March, June. Free catalog. **ENROLL NOW**

INDIANA TECHNICAL COLLEGE
1792 E. Washington Blvd., Fort Wayne 2, Indiana

**Every RADIOMAN
can use these
SERVICE HINTS!**

Valuable Manual Yours—FREE
Write today—no obligation

FEILER ENGINEERING CO. Dept. 9RC2-1
8026 N. Monticello Ave., Skokie, Ill. (Suburb of Chicago)

Every page of "How to Simplify Radio Repairs" is packed with on-the-bench, practical ideas.

You can't beat
Radio-Electronics
for complete coverage of
Radio, Television and Audio

TELEVISION COMMUNICATIONS INSTITUTE
205 W. Wacker Dr., Dept. RE-10, Chicago 6, Ill.

Address.....Zone.....State.....
City.....
 BEGINNERS check here for Pre-TV Radio Course.

standard brands
TUBES PRICES Slashed!
individually boxed

0Z4	\$.45	6BD6	\$.45	12AU6	\$.46	50B5	\$.47	6AG7	\$.84	6L6G	\$.81
1T4	\$.55	6BE6	\$.46	12BA6	\$.43	50C5	\$.48	6AH6	\$.75	6S4	\$.42
1T5	\$.64	6BQ6G	1.49	12BE6	\$.48	50L6GT	\$.50	6AS7G	2.88	6SC7	\$.68
1X2A	\$.63	6BQ6GT	\$.90	12BH7	\$.63	1B3GT	\$.63	6AX5GT	\$.40	6SF5	\$.51
3Q5GT	\$.63	6CB6	\$.53	12SA7GT	\$.50	1N5GT	\$.55	6B4G	\$.95	6SH7	\$.59
5U4G	\$.40	6J5GT	\$.40	12SJ7GT	\$.47	1R5	\$.54	6BA7	\$.65	6SJ7	\$.47
5Y3G	\$.28	6J6	\$.63	12SK7GT	\$.50	1S4	\$.63	6BF5	\$.55	6SL7GT	\$.65
6AG5	\$.53	6KA7	\$.39	12SN7GT	\$.55	1S5	\$.45	6BH6	\$.60	6SR7	\$.38
6AK5	\$.95	6SA7	\$.45	12SQ7GT	\$.45	1U4	\$.55	6BJ6	\$.50	6SS7	\$.48
6AL5	\$.40	6SN7GT	\$.52	198G6G	1.39	1U5	\$.45	6BN6	\$.81	6T8	\$.75
6AQ5	\$.46	6SQ7GT	\$.45	25AV5GT	\$.83	3A5	1.06	6C4	\$.39	12AU7	\$.52
6AR5	\$.35	6V6GT	\$.51	25BQ6GT	\$.90	3O4	\$.60	6C5	\$.51	12SG7	\$.52
6AS5	\$.48	6W4GT	\$.49	25L6GT	\$.47	3S4	\$.57	6CD6G	1.55	19T8	\$.75
6AT6	\$.36	6W6GT	\$.50	35B5	\$.47	3V4	\$.58	6D6	\$.65	25Z6GT	\$.41
6AU6	\$.41	6X4	\$.35	35C5	\$.47	5T4	1.08	6E5	\$.66	117N7GT	1.09
6AV5GT	\$.87	6X5GT	\$.35	35L6GT	\$.47	5V4G	\$.73	6F5	\$.48	117P7GT	1.09
6AV6	\$.36	12AL5	\$.48	35W4	\$.31	6AB4	\$.46	6F6GT	\$.48	117Z3	\$.42
6A6	\$.43	12AT6	\$.46	35Z5GT	\$.30	6AC7	\$.80	6H6	\$.49	17EP4	\$.19
6BC5	\$.53									20CP4	\$.24

Many other types equally low priced—include all your tube needs with your order.
One of the largest stocks in the country!
Min. Order \$25.00. Terms: 25% with order, balance C.O.D.
All merchandise subject to prior sale, F.O.B. New York City. Mail order division.

Television Materials Corp.
120 LIBERTY ST., NEW YORK 6, N.Y. • Cortlandt 7-4307

Still Time To Get
UNDER THE WIRE

This is not intended as a pun, but it's quite evident that with wire certain to be in short supply and low-low Summer prices still prevailing, IT'S WISE TO SEE YOUR NEAREST J.S.C. DISTRIBUTOR N-O-W . . . fill your requirements for now and the months ahead!

300-Ohm TV Lead-In Wire—
finest quality J.S.C. Wire—is
still at low Summer prices. With
prices certain to rise this Fall,
it's WISE TO STOCK UP NOW.
. . . Be Protected . . . Stock Up!

SEE YOUR NEAREST J.S.C. DISTRIBUTOR



You Get Highest Quality and Top Efficiency When You Buy Wire Products From the Dealer Displaying the Orange & Blue J.S.C. Disc!!

OPPORTUNITY AD-LETS

Rates—35¢ per word (including name, address and initials). Minimum ad 10 words. Cash must accompany all ads except those placed by accredited agencies. Discount for 12 issues, 20%. Misleading or objectionable ads not accepted. Copy for November issue must reach us before August 21, 1952.
Radio-Electronics, 25 W. Broadway, New York 7, N.Y.

WANTED: AN TRC-1 EQUIPMENTS, T14 TRANSMITTERS, R19 RECEIVERS, TS32 TEST OSCILLATORS. Any condition or quantity. Box 752-2, Radio-Electronics, 25 West Broadway, New York 7, N. Y.

SPEAKERS REPAIRED at wholesale prices. Guaranteed workmanship. Fast service. Amprito Speakers Service, 70 Vesey St., New York 7, N. Y.

WE REPAIR, CONVERT, SELL, ALL TYPES OF electrical instruments, tube checkers and analyzers. Hazleton Instrument Co. (Electric Meter Laboratory), 128 Liberty Street, New York, N. Y. Telephone—BARclay 7-1239.

WANTED: AN/APR-4, other "APR-" "TS-" "IE-" ARC-1, ARC-3, ART-13, BC-348, etc. Microwave Equipment, everything Surplus. Special tubes, Tec Manuals. Lab Quality Equipment, Meters, Fast Action, Fair Treatment, Top Dollar! Littell, Farhills Box 26, Dayton 9, Ohio.

NEW RCA 3AP1A ORIGINAL CARTONS \$6.75 EACH. Tubes, surplus-bought, sold, Free Hst. Write MARK, Box 14, New York City 72.

EIGHT RADIO BUILDING PLANS \$1.00, Master Kit Company, Box 206, Belleville, Ontario.

FIVE ELEMENT TV YAGI BEAMS, ALUMINUM Tubing, etc. Write for prices, Willard Radcliff, Fostoria, Ohio.

TV AND FM ANTENNAS, YAGI CONICAL BOW-TIE Mounts, accessories. Lowest prices. Wholesale Supply Co., Lunenburg 2, Mass.

ENJOY 3 COLOR TELEVISION SCREEN, SEND \$1. State Screen Size. Zingo Products, Dept. K, Johnstown, New York.

ELECTRONIC LITERATURE

Any or all of these catalogs, bulletins, or periodicals are available to you on request direct to the manufacturers, whose addresses are listed at the end of each item. Use your letterhead—do not use postcards. To facilitate identification, mention the issue and page of RADIO-ELECTRONICS on which the item appears. All literature offers void after six months.

VEE-D-X CATALOG

The LaPointe Plascomold Corp. has issued a new 23-page illustrated catalog describing VEE-D-X TV antennas, towers, boosters, and accessories.

A copy of catalog No. 52 is available upon request to The LaPointe Plascomold Corp., Rockville, Conn.

ELECTRONIC FLASH HANDBOOK

The Sprague Electronic Flash Handbook is a 14-page, 8½ x 11-inch booklet on constructing four different low-voltage electronic flash outfits designed around Sprague's low-leakage electrolytic capacitors and the latest types of flash tubes.

A copy of the handbook (No. C-703) can be obtained for 35¢ from Sprague dealers, or from Sprague Products Co., North Adams, Mass.

CONDENSED CATALOG

Electro-Voice has issued a new condensed catalog No. 113. Microphones, phono-cartridges for all three speeds, hi-fi speakers, drivers, horns and crossovers, folded-horn corner enclosures, 2-, 3- and 4-way speaker systems, automatic self-tuning Tune-O-Matic and Tenna-Top boosters, and the TeleVider distribution system for multiple TV installations are described and illustrated.

For free copy write to Electro-Voice, Inc., Buchanan, Mich.

TV TUBE COMPLEMENTS

Sylvania's new enlarged third edition of its Television Receiver Tube Complement Book lists receiving and picture tube types for nearly 4,000 different TV sets now in home use. Receivers are listed alphabetically by manufacturers, and the total number of tubes required for each is also given.

Copies of the 120-page wire-bound book may be obtained for 75¢ from distributors or the Advertising Department, Sylvania Electric Products Inc., Emporium, Pa.

PHONO NEEDLE CATALOG

Full information on every known type of needle replacement appears in the Jensen Industries' phono needle catalog No. 52. The 16-page brochure is cross-referenced according to phonograph manufacturer, cartridge manufacturer, and competitive needle sources. Information is also supplied on Jensen's magnetic recording tape.

Available free from parts distributors or direct from Jensen Industries, Inc., 329 S. Wood St., Chicago 12, Ill.

—end—

When Writing Advertisers Please Mention
RADIO-ELECTRONICS

R. L. Triplett, president of TRIPLETT ELECTRICAL INSTRUMENT CO., Bluffton, Ohio, was presented with a gold watch by his sales force on the occasion of his



Mr. Triplett (right) accepts 50-year award from E. K. Seyd, as A. D. Plamondon, Jr., RTMA Chairman, looks on.

50th year in the industry. The presentation was made by E. K. Seyd, Andover, Conn., manufacturers' representative and a 20-year veteran with the Triplett sales organization.

George Mucher was promoted to executive vice-president of CLAROSTAT MANUFACTURING CO., Dover, N. H., in a



Clarostat executives William J. Mucher, J. J. Repetto, George Mucher, Walter J. Mucher, Fran J. Chamberlain.

series of top-level personnel changes. Other promotions: Fran J. Chamberlain, sales manager, Distributors Division; Walter J. Mucher, plant production manager; William J. Mucher, chief engineer; and Jacob J. Repetto, superintendent, design and drafting. They have all been associated with Clarostat for years.

Glen McDaniel, the first full-time paid president of the RTMA, announced his resignation, effective October 1, at the association's 28th Annual Convention



B. L. Graham, F. R. Lack, John T. Koehler, Robert C. Sprague, RTMA President McDaniel, and Chairman Plamondon. at the Palmer House in Chicago. A. D. Plamondon, Jr., president of Indiana Steel Products Co., was elected chairman of the Board of Directors succeed-

Your best book buy!

The new Gernsback Library

**Streamlined!
Enlarged!**

Gives you thorough and accurate coverage of practical electronics at just a fraction of the usual cost of technical books!

Check these important new books on RADIO • TV • AUDIO!

TELEVISION TECHNICAL NOTES. No. 46—\$1.50. Cuts down on TV trouble-shooting time! Tells you how to find and correct more than 600 troublesome bugs which have cropped up in scores of sets made by 27 leading manufacturers. Compiled by the editors of RADIO-ELECTRONICS from the reports of practicing service technicians and from manufacturers' servicing notes. 128 pages.

BASIC RADIO COURSE. No. 44—\$2.25. By John T. Frye. At last a book that actually makes learning fundamentals a pleasure! RADIO-ELECTRONICS' popular technician-writer leads you along the rocky path of theory from Ohm's Law to an understanding of advanced servicing techniques and makes what you've learned stick. 176 pages. Durable hard cover.

RADIO TUBE FUNDAMENTALS. No. 45—\$1.00. Gets right to the heart of radio! Gives you a clear understanding of what radio tubes are and how they work in a circuit. Used as a reference text at New York University. The author is an instructor and engineer. 96 pages.

MODEL CONTROL BY RADIO. No. 43—\$1.00. Tells what radio control is and how to use it in model airplanes, boats and autos. Covers construction of coders, transmitting and receiving systems and other components as well as complete systems. 112 pages.

HIGH-FIDELITY TECHNIQUES. No. 42—\$1.00. By James R. Langham. Probably the best book on hi-fi ever written—at any price! In a sly and highly readable style, RADIO-ELECTRONICS' famous audio writer tells you how to design your own equipment and get top performance from it. 112 pages.

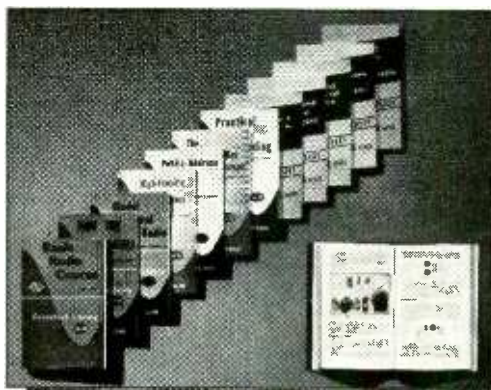

Have you read these acclaimed best sellers?

PUBLIC ADDRESS GUIDE. No. 41—75c. Tells how to earn more money in PA work! Covers installation, maintenance, construction. Construction details for a system to handle 90% of all P.A. jobs.

THE CATHODE-RAY OSCILLOSCOPE. No. 40—75c. How the 'scope works and how to use it in servicing TV, FM and AM receivers, amateur equipment and audio amplifiers.

PRACTICAL DISC RECORDING. No. 39—75c. Covers theory as well as technique. A full chapter for each component. Explains in practical detail the elements of making quality records.

AMPLIFIER BUILDER'S GUIDE. No. 33—50c. For the designer and builder of audio equipment. A wide range of technical data on amplifier design and construction. Proven best-seller!

ADVANCED SERVICE TECHNIQUE. No. 32—50c. Devoted to specialized problems not found in ordinary texts. A treasury of ideas, methods and procedures for advanced technicians.

RADIO QUESTIONS & ANSWERS. No. 31—50c. Answers your tough ones on circuits, amplifiers, transmitters, etc. Diversified, practical information which can be put to daily use.

UNUSUAL PATENTED CIRCUITS. No. 30—50¢. A gold mine of important hook-ups. Control circuits, detectors, amplifiers, power supplies and foreign circuits.

HANDY KINKS AND SHORT CUTS. No. 29—50¢. A treasury of time savers! Antennas, power supplies, test equipment, etc. A great value at this give-away price!

See your distributor—or mail this coupon

RADCRAFT PUBLICATIONS, INC., Dept. 92
25 West Broadway
New York 7, N. Y.

Enclosed is my remittance of \$ _____
Please send me postpaid the books checked below:

- 46 45 44 43 42 41 40
 39 33 32 31 30 29

Name _____
(Please print clearly.)

Street _____

City _____ Zone _____ State _____

The Gernsback Library is published by the publishers of RADIO-ELECTRONICS

FLASH! Tube Prices SMASHED!

ALL TUBES listed below carry 6-month guarantee—exception only burnouts and breakages. At these sensationally low prices, these tubes must be ordered in quantities of AT LEAST 10 ASSORTED TUBES. Add 10% for orders under 10 tubes. All individually boxed in attractive Greylock Cartons.

SPECIAL OFFER: Additional 5% discount on all shipments of 100 tubes or more assorted!

024M	\$.59	6BE6	\$.49	7C6	\$.89
1A7GT	.89	6BF5	.69	7C7	.89
1B3GT	.89	6BG6G	1.29	7L7	.99
1H5GT	.69	6BH6	.69	7N7	.79
1L4	.49	6BJ6	.59	7X7	.79
1LA4	.89	6BK7	.89	807	1.79
1LC5	.79	6BN6	1.09	12A8GT	.49
1LD3	.89	6BQ6GT	.79	12AT7	.49
1LN5T	.89	6BQ7	1.49	12AT7	.79
1NS5T	.69	6C4	.49	12AU6	.49
1RS	.59	6C5GT	.49	12AU7	.39
1S5	.49	6C6	.49	12AV6	.39
1T4	.59	6CB6	.49	12AX7	.69
1U4	.49	6CD6G	1.49	12AX4GT	.69
1U5	.49	6E5	.79	12AX7	.59
1X2	1.09	6F6GT	.59	12AZ7	1.29
3A4	.59	6J5GT	.49	12BA6	.49
3A5	.79	6J6	.89	12BA7	.99
3LF4	.99	6J7	.49	12BD6	.59
3Q4	.49	6K6GT	.59	12BE6	.49
3Q5GT	1.09	6L6G	1.19	12BH7	.99
3S4	.59	6L6GA	1.19	12J5GT	.59
3V4	.49	6S4	.49	12S47GT	.79
5U4G	.59	6S8GT	.69	12S7GT	.89
5V4G	.89	6SA7GT	.69	12SN7GT	.99
5X4G	.59	6SC7	.99	12SQ7GT	.99
5Y3GT	.49	6SG7	.89	12S8GT	.79
5Y4G	.69	6SJ7GT	.69	14A7	.99
6AB4	.69	6SK7GT	.49	14B6	.79
6AC7M	1.09	6SL7GT	.69	14D7	.99
6AG5	.69	6SN7GT	.59	19B6GG	1.29
6AG7M	1.19	6SQ7GT	.59	19T8	.99
6AH6	1.29	6SR7	.69	25B06GT	.79
6AK5	.89	6T8	.79	25L6GT	.59
6AL5	.49	6U4GT	.59	25W4GT	.49
6AQ5	.49	6U5	.69	25Z5	.49
6AQ6	.69	6U8	.89	25Z6GT	.69
6AR5	.59	6V3	1.59	35B5	.59
6AR6	2.49	6V6GT	.49	35C5	.59
6AS5	.69	6W4GT	.49	35L6GT	.79
6ATR	.49	6W6GT	.49	35W4	.49
6AUG	.49	6X4	.49	35Y4	.69
6AV6	.49	6X5GT	.49	35Z5GT	.49
6AW6T	1.09	6Y6G	.79	50B5	.59
6AX4GT	.69	7A4	.69	50C5	.59
6AX5GT	.79	7A6	.89	50L6GT	.59
6BA6	.49	7B6	.59	80	.59
6BC5	.69	7B7	.89	117Z3	.49
6BD6	.59				

SENSATIONAL PRICE SLASH!



FAMOUS MAKE TV BOOSTER
Model 410
List \$32.50. Reg. Dealer Cost \$19.11
ONLY \$14.95
A FEW LEFT!

McMURDO SILVER FM-TV BOOSTER

Very simple to hook up. Instructions included.
Special! WHILE THEY LAST!
\$9.95



MANY ADDITIONAL VALUES, in Radio, TV and Electronic components and accessories! Send for our Great New Bargain Supplement 100-4.
All Prices F.O.B. NYC. Please include postage and insurance with your remittance. 25% Deposit required on all C.O.D. orders.

GREYLOCK ELECTRONICS Dept. C9
SUPPLY CO.
115 Liberty Street New York 6, N. Y.

ON-THE SPOT BATTERY RECORDER

WALKIE-RECORD-JALL 8 lb. miniature BATTERY RECORDER-PLAYBACK
Continuous, permanent, accurate, indexed recording at only 5c per hr. Instantaneous permanent playback. Picks up sound up to 60 ft. Records conferences, lectures, dictation, 2-way phone & sales talks; while walking, riding or flying. Records in closed briefcase with "hidden mike"! Write for details.

MILES REPRODUCER CO., INC.
812 BROADWAY Dept. RE-9 NEW YORK 3, N. Y.

WANTED

BD110 Telephone Switchboards, BD100 Telegraph Switchboards, BD90 Power Boards, EE101 V-F Ringers, BE72 Cabinets, FM19 Frames, RA43, RC30, KS598B, RA87, RA37, RA91 Rectifiers, BD101 Test Boards, SB6 Switchboards, Type CF1A, CF3A, CF2B Carrier Equipments. Any condition and quantity.

Box 752-1 Radio Electronics
25 W. Broadway, New York 7, N. Y.

ing Robert C. Sprague, president of Sprague Electric Co. He appointed a committee to make recommendations for a new RTMA president. Leslie F. Muter was re-elected RTMA treasurer for his 17th term. Dr. W. R. G. Baker, vice-president of General Electric was reappointed as director of the Engineering Department, James D. Secrest was reappointed secretary and general manager, and John W. Van Allen was re-named general counsel.

Frank R. McMillan joined the INTERNATIONAL RESISTANCE CO., Philadelphia, as assistant Radio Division sales manager. He comes to the company from DuMont where he was a district sales manager in the Cathode-Ray Tube Division.



F. R. McMILLAN

James J. Tynan, former manager of Commercial Sales, was appointed manager of the Equipment Sales Division of RAYTHEON MANUFACTURING Co., Waltham, Mass. He replaces Ray C. Ellis, vice-president, who was named manager of the Raytheon International Division.



J. J. TYNAN

J. A. (Shine) Milling, who recently resigned as director of the Electronics Division of the NPA and chairman of the Electronics Production Board of the DPA to return to private industry, was appointed executive vice-president and general manager of HOWARD W. SAMS & Co., Indianapolis. Before entering Government service, Mr. Milling had been operating vice-president of the RCA Service Company.



J. A. MILLING

Personnel Notes

... Robert A. Penfield, advertising supervisor of the Tube Division of SYLVANIA ELECTRIC PRODUCTS, was promoted to advertising manager of the Radio and Television Picture Tube Division, Electronics, Parts, and Tungsten and Chemical Divisions.

... Bob Abbott, advertising manager and assistant sales manager of Littelfuse, Inc., Desplaines, Ill., for eight years, joined the staff of BURTON BROWNE ADVERTISING, Chicago. Herb Cornelius, former field sales manager of Littelfuse, was promoted to sales manager.

... Frederick P. Harvey, former ad-

LOVE THAT QUICK-WEDGE!

I use it instead of a conventional screwdriver!



Quick-Wedge
SCREW-HOLDING SCREWDRIVER

unconditionally guaranteed

ASK FOR IT AT YOUR DEALER
KEDMAN CO., 233 S. 5th WEST • SALT LAKE CITY, UTAH

Please Mention
RADIO-ELECTRONICS
When Writing
Advertisers

CODE-SENDING SPEED

Be a "key" man. Learn how to send and receive messages in code by telegraph and radio. Commerce needs thousands of men for jobs. Good pay, adventure, interesting work. Learn at home quickly through famous Candler System. Quality for Amateur or Commercial License. Write for FREE BOOK.
CANDLER SYSTEM CO.
Dept. 3-K, Box 928, Denver 1, Colo., U.S.A.



EVERY RADIOMAN
Can Use These
SERVICE HINTS!

Valuable Manual Yours—FREE!

Every page of "How to Simplify Radio Repairs" is packed with on-the-bench, practical ideas. Contains photos, charts, diagrams—no fluff—no vague theory. In plain every-day language it gives you priceless suggestions—new servicing ideas. You'll use and benefit from the experience of experts. Partial list of contents: How to Localize Trouble; How to Service Amplifiers; How to Test for Distortion; How to Test Audio Circuits; How to Test Speakers; How to Find Faults in Oscillators; How to Test Radio Parts—and it's all yours—FREE. No obligation.



FEILER SEND COUPON OR GOVERNMENT POSTCARD FOR YOUR FREE COPY TODAY!

FEILER ENGINEERING CO., Dept. 9RC2
8026 N. Montecito Ave.,
Skokie, Ill. (Suburb of Chicago)
Please RUSH my FREE copy of "How to Simplify Radio Repairs."
Name.....
Address.....
City..... Zone..... State.....

vertising and sales promotion manager of SYLVANIA ELECTRIC PRODUCTS' Radio and Television Picture Tube Division, Electronics, Parts, and Tungsten and Chemical Divisions, joined the staff of Fuller & Smith & Ross, Inc., New York City advertising agency, as account executive assigned to the Westinghouse Electronic Tube Division.

... Bob Mosher, formerly with Art Cerf & Co., will travel in the New England territory for MERIT COIL & TRANSFORMER CORP., Chicago.

... Fred H. O'Kelley, Jr., former Cincinnati district representative for the GENERAL ELECTRIC Tube Department, was appointed product manager for G-E receiving tubes.

... Adrian S. Price joined RMS, New York City, as director of public relations and advertising. He had been with the Dexter Chemical Corp.

... S. H. Van Wambeek joined the HAMMARLUND MANUFACTURING Co., New York City, as chief engineer, coming to the company from Knapp-Monarch Co.

... Richards W. Cotton is on a leave of absence from PHILCO CORP., to act as chairman of the Electronics Production Board of the DPA, and director of the Electronics Division of the NPA.

... M. A. De Matteo, well known in

distributor circles, joined the ASTRON SALES CORP., East Newark, N. J., manufacturer of capacitors and of interference filters, to head jobber sales.

... Stanley Kramer was promoted to chief applications engineer of the Germanium Products Division of RADIO RECEPTOR Co., Inc., Brooklyn, N. Y. Herbert Friedman, formerly an engineer with Columbia University, was appointed sales engineer of the division.

... J. H. (Robby) Robinson was appointed president of RADIO ESSENTIALS, INC., Mount Vernon, N. Y., which has resumed business as a subsidiary agency of American Radio Hardware Co., Inc.

... Robert H. Dolbear was appointed sales engineer of the Instrument Division of ALLEN B. DU MONT LABORATORIES. He had been with Curtiss-Wright Corp.

... John Ouse, formerly with American Television Co., joined THOMAS ELECTRONICS, INC., Passaic, N. J., in charge of Midwest sales.

... Morris L. Finney, Jr., a former Chicago manufacturers' representative, joined THE FINNEY Co., Cleveland antenna manufacturer, as sales manager.

... Lester C. Harder and John B. O'Donnell were appointed assistant

manager and director of purchasing, respectively, for the National Defense Department of MOTOROLA.

... Arie Liberman, president of TALK-A-PHONE Co., Chicago, was granted a patent on a new selector device for intercom systems.

... K. B. Shaffer was appointed manager of kinescope renewal sales of the RCA TUBE DEPARTMENT, Harrison, N. J. D. M. Branigan continues as manager of receiving tube renewal sales, and A. G. Petrasek was appointed manager of electronic components renewal sales, replacing Mr. Shaffer. All are veterans with RCA. Separate kinescope and receiving tube sales functions were created within the renewal sales organization to improve service to the expanding electronics market.

... Graham R. Treadway joined LA-POINTE-PLASCOMOLD CORP., Rockville, Conn., manufacturer of Vee-D-X antennas and accessories, as assistant to J. L. Respass, president. He was previously president of the Horton-Bristol Mfg. Co. LaPointe-Plascomold also announced that Charles D. Townsend had joined the company as director of manufacturing. He has a wide background in engineering and management.

—end—

TeleSound CUSTOM-BUILT TV CABINETS

DIRECT FROM MANUFACTURER TO YOU—COMPARE PRICE and QUALITY!



H:25", D:21 1/2", W:25" Wgt: 50 lbs.
TABLE MODEL 500 \$42.00



As above, for 24" Picture Tube
H:31", D:24", W:27" Wgt: 60 lbs. \$55.80

H:40 1/2", D:22 1/2", W:25 1/4"
Wgt:60 lbs. CONSOLE MODEL 200 \$45.50



H:40 1/2", D:24", W:25"
Wgt: 100 lbs. CONSOLE MODEL 800 \$82.50



CREENZA MODEL 1200
H: 35", D: 23", W: 40"
Shpw. Wt. approx. 100 lbs. For 17", 20", 21" Picture Tube, includes record-changer compartment. TV only, for 24" and 27" This cabinet also available for TV only (17" to 24" CRT) side mount, 34" Wide. \$130.



Be price conscious! TELESOUND Wholesale Prices enable you to sell more, make a BETTER PROFIT for yourself!

ALL PRICES TAX INCLUDED

All TeleSound cabinets illustrated are available in Ribbon Stripe Mahogany. Model 200 also available in Walnut. All cabinets can be had in Blonde Korina at 10% additional. These cabinets are custom built and drilled to fit standard 630 type chassis. We can supply them with undrilled panel to fit any other chassis you specify.

Famous SUPER DeLUXE 630 CHASSIS

—YOUR CHOICE—
REGAL
or
VIDEO



TERRIFICALLY
LOW PRICED!
\$139.50

- 30 tubes—for 16" to 24" Picture Tubes
- High Efficiency High Voltage Circuit
- Keyed AGC

- Automatic brightness control
- Special extra high gain Cascade Standard Coil Tuner

- Directly adaptable for UHF.
- 12" Quality Speaker
- Factory wired, aligned, tested.

- Complete, ready to play, including knobs and hardware
- Less CRT

Techmaster C-30 Chassis, Complete with Tubes & Speaker, Less CRT. \$149.50

FREE OFFER! Schematic Diagram and complete 24 page service manual FREE with any of these chassis!

TV PICTURE TUBES

SHELDON BLUE LABEL
One Year Guarantee
Dumont—6 Mos. Guarantee

(Don't be misled—demand guaranteed standard brands!)

12 1/2" Black or White	\$20.50	19" Round (Bik)	\$33.50
14" Glass Rect. (Bik)	\$20.50	20" Rectangular (Bik)	\$35.50
16" Glass Round (Bik)	\$30.50	21" Rectangular (Bik)	\$39.50
16" Glass Rect. (Bik)	\$30.50	24" Metal	\$69.50
17" Rectangular (Bik)	\$29.50	27" Rectangular	Wholesale Price on Request

SPECIAL COMBINATION OFFERS!

SAVE MONEY! Order the cabinet of your choice from the TeleSound models illustrated, in combination with the famous 630 TV Chassis. (Regal or Video), 12" speaker, and your choice of picture tube. If Techmaster C-30 chassis desired, add \$10.00 to combination price. Check these sensationally low prices:

CABINET STYLE	COMBINED WITH Super 630 chassis, 12" speaker, and			
	17" CRT	20" CRT	21" CRT	24" CRT
500	\$205.75	\$211.60	\$215.50	\$258.20
200	209.15	215.00	218.90
800	245.10	251.05	254.95
1200*	291.50	297.35	301.25

*Record Changer not included.

Please include 25% deposit with orders, balance C.O.D. All shipments F.O.B., NYC
"Designers & Manufacturers of Custom TV and Radio Furniture"

TeleSound CORPORATION

421 West 28th Street
New York 1, N.Y.
Phone: WI 7-0719

Become an Electrical Engineer



MAJOR IN ELECTRONICS



- B. S. Degree in 36 Months
- Radio-Television Technician Certificate in 18 Months

By 1954 there will be at least two positions for every engineering and technician graduate. This College offers a tested plan that permits you to enter these vast employment opportunities at an early date. First — you save a valuable year through optional year-round study. Second — you can receive advanced credit for prior training gained in the armed forces, other schools or field experience.

Enter Both Radio and Television Through This Plan

12 months or one-third of the B. S. degree course (Electronics major) — also brings you the Radio Technician's certificate. An added 6-month course qualifies you for the Radio-TV Technician's Certificate. Recent developments open unlimited opportunities for TV technicians and engineers.

The Proven "UNIT CHASSIS SYSTEM"



of teaching was developed here. It "breaks down" the TV set by stages. You learn every component of all types and makes — and are prepared for future design changes, including the advent of color.

General Preparatory Course

Exclusive 3-month course is tailor-made to help young men fulfill academic deficiencies and meet engineering admission requirements. Terms open October, January, April, July Over 48,000 former students from all states and 23 overseas countries. Faculty of trained specialists. Modern laboratories and equipment. Nonprofit technical institute and college in its 49th year.

MILWAUKEE SCHOOL OF ENGINEERING

FREE — Write for "Occupational Guidance Bulletin," "Your Career" booklet, and catalog.

Milwaukee School of Engineering
Dept. RE 952, 1025 N. Milwaukee
Milwaukee, Wisconsin

Without obligation send Catalog for Electrical Engineering, B. S. Degree, major in Electronics; Power; "Your Career"; Occupational Guidance Bulletin on: Radio-TV; Electrical Power; Welding; Heating, Refrigeration Air Conditioning; Mechanical Engineering, B.S. Degree; Preparatory.

Name..... Age.....
Address.....
City..... Zone..... State.....
If veteran, indicate date of discharge.....

LEARN CODE AND THEORY AS LOW AS \$6.95

ECONOMICAL HOME STUDY COURSES PREPARE YOU FOR:

F.A.S.S. COMMERCIAL CODE EXAMS AND THEORY EXAMS THE EASY FAST WAY. BEAT THE ADVANCED CLASS DEADLINE (closes Dec. 31).

AMATEUR AND COMMERCIAL CODE EXAMS THE EASY WAY. 78 RPM

3 "AMECO" COURSES AVAILABLE:

- #1—NOVICE CODE COURSE. You get and keep 10 recordings (alphabet through 8 W.P.M.). Includes typical F.C.C. type code exams. Free instruction book — learning how to send and receive code the simplest, fastest way; plus charts to check your receiving accuracy all for the low price of only **\$7.95**
- #2—SENIOR CODE COURSE. You get and keep everything given the Novice Course except that you get 22 recordings (alphabet through 18 W.P.M.) plus an album, plus typical F.C.C. type code exams for General class and 2nd class commercial telegraph licenses. All this for only **\$12.95**
- #3—COMPLETE RADIO THEORY COURSE. A complete, simplified home study theory course in radio, covering the Novice Technician, conditional, general, and advanced classes—all under one cover—with hundreds of typical F.C.C. type questions to prepare you for license exams. No technical background required. You also get, FREE, one year of consultation and a guide to setting up your ham station. All for the amazingly low **\$6.95** low price of

All Courses Have Money-Back Guarantee See Them at Your Dealer or Write for Free Information
AMERICAN Electronics Co., Dept. RE9
1451QW kind Ave., N.Y. 59, N.Y.
Tel. No. DAYTON 9-4815

RADIO & TELEVISION TRANSMITTERS LAB. WORK EVERY DAY LEARN BY EXPERIENCE REHRIG SCHOOL

11-13 S. GAY ST. BALTIMORE 2, MD. Lex. 3195

RADIO ENGINEERING IN 27 MONTHS DEGREE

Intensive, specialized course including strong basis in mathematics and electrical engineering, advanced radio theory and design, television. Modern lab. Low tuition. Self-help opportunities. Also B.S. degree in 27 months in Aeronautical, Chemical, Civil, Electrical, and Mechanical Engineering. C.T. Gov't approved. Enter September, December, March, June, Catalog.

INDIANA TECHNICAL COLLEGE
159 E. Washington Blvd., Fort Wayne 2, Indiana

RADIO and TELEVISION ELECTRONICS

in all Technical Phases
New Classes (Day & Evening)
Start 1st of Dec., Mar., June, Sept.
FREE PLACEMENT SERVICE for GRADUATES
For Free Catalog write Dept. RC-52
RCA INSTITUTES, INC.
A Service of Radio Corporation of America
350 West 4th St., New York 14, N. Y.

RADIO COURSES

- RADIO OPERATING • CODE
 - RADIO SERVICING • ELECTRONICS
 - F.M. TELEVISION
- Preparation for Civilian, Maritime, Army and Navy license requirements.
Write for Catalog TE

TRADE & TECH. SCHOOL 15 W 63 St. N. Y. 23 ENdicott 2-8117

LEARN TELEVISION

ELECTRONICS and RADIO Engineering Laboratory and Classroom Training. Day and Evening Classes.

Write for illustrated Catalog
ELECTRONICS INSTITUTE, Inc.
21 HENRY DETROIT 1 MICH

TV SERVICING E-X-C-L-U-S-I-V-E-L-Y

DO YOU want to get into TV servicing . . . operate your own TV shop . . . get into the \$5,000 a year income bracket? If you are serious-minded, you CAN increase your earning power within a few months.

To do this, you need the BEST—the most COMPLETE TV servicing & maintenance training available. TV Servicing is a highly-skilled type of work that requires PRACTICAL, SPECIALIZED training. Engineering theory, design factors & mathematics are not essential to TV Servicing.

LEARN the operation of every TV component; how to use TV test equipment; how to diagnose TV troubles & locate defective parts; HOW TO SERVICED ALL TYPES OF TV & RADIO RECEIVERS in our fully-equipped shops.

W.R.T.I. students actually work on more than 20 different types of popular, name-brand TV sets. They learn to use more than 15 different types of test & measuring instruments & equipment. THIS is the kind of training that CAN prepare you for a SUCCESSFUL career in TV SERVICING.

Without obligation, write for our new booklet E-9. It's illustrated to show you the best-equipped trade school TV shop & laboratory on the West Coast.

APPROVED FOR VETERANS

Western-Radio TELEVISION Institute
341 West 18th St., Los Angeles 15, Calif.

Unlimited Opportunities in

RADIO ENGINEERING

DEGREE IN 27 MONTHS

Complete Radio Engineering course including Telev., U. H. F. and F. M. Bachelor of Science Degree also in Mech., Civil, Elect., Chem., and Aero. Eng.; Bus. Adm., Acct. Extensive campus, modern buildings, well equipped labs. Low cost. Prep courses. Personalized, practical instruction. Founded 1883. Placement service. Growing shortage of engineers. Prepare now for unlimited opportunities ahead. Enter September, January, March, June. Write for catalog.



TRI-STATE COLLEGE

2492 College Ave. ANGOLA, IND.

FOR THE FIRST TIME!

For several years you've read about the Don Martin School now—for the first time—we are prepared to offer a course by mail. You can obtain your first class radio telephone operator's license from this special course. Operators are desperately needed now by radio and TV stations as well as the aircraft industry. Secure your future.

Be certain that your training is of the best, enjoy the school recognized by the profession. Write today for full information.

THE DON MARTIN SCHOOL OF RADIO AND TELEVISION ARTS AND SCIENCES
Correspondence Section
1655 No. Cherokee, Hollywood 28, Calif. HU. 2-3281.

BE A RADIO ENGINEER!

You can enter this uncrowded, interesting field. In defense expansion, new developments in electronics demand trained technicians. Study all phases radio & electronics theory and practice: TV; FM; broadcasting; servicing; aviation; marine, police radio. 18-month course equal in radio content to 4 yrs. college. U.S. or equivalent required. Begin Jan., March, June, Sept. Campus life. Catalog.

VALPARAISO TECHNICAL INSTITUTE
Dept. C Valparaiso, Ind.



TELEVISION-RADIO ELECTRONICS

Training in all branches television, radio and electronics. FCC exam. preparation. Write for free catalog.

COMMERCIAL RADIO INSTITUTE
(Founded 1920)

38 W. Biddle St., Baltimore 1, Md.
Approved by Maryland State Board of Education

THE 3 B...

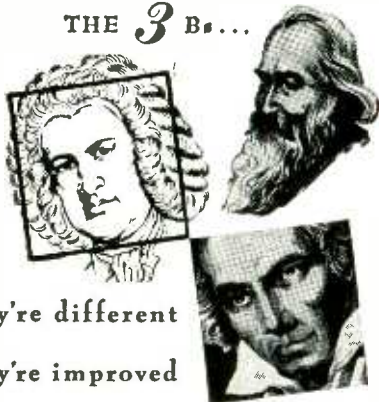

they're different
they're improved

they're better than ever!

Yes, Bach, Beethoven and Brahms are now better than ever—we don't mean we've improved their music, but we do mean we've improved the reproduction of their recorded music.

It's the new, improved Pickering Cartridges that give credence to this claim. Yes, Pickering Cartridges are different. They're improved. They're better than ever. Pickering patented Cartridges are superior in every way, by providing higher frequency response, negligible intermodulation distortion, better tracking characteristics. Pickering diamond stylus cartridges not only wear longer but more important, they preserve the musical quality and prolong the life of your record library.

PICKERING & CO., Inc.

Oceanside, L. I., N. Y.

For details and literature address Department P

**A Full Size
LIGHTNING ARRESTER
at the Price of a Midget**

RADIART

LIGHTNING ARRESTER

MODEL TA5 Real protection against lightning and static charges — the RADIART Lightning Arrester has all the features! Fits anywhere... inside or out... handles standard or jumbo leads... no wire stripping necessary... does not unbalance the line... low internal capacity... no loss of signal... internal resistance "leaks off" static discharge! UNDERWRITERS LABORATORIES APPROVED.

THE RADIART CORPORATION
CLEVELAND 13, OHIO

SEPTEMBER, 1952

MATSINGER'S MIDGETS

Dear Editor:

If Mr. Matsinger admits in his article on page 40 of the July RADIO-ELECTRONICS that he might be branded a heretic, he expected what he deserves.

His cutthroat advice is downright ridiculous and an invitation to bankruptcy. The radio service industry has always been plagued by the unwillingness of the public to pay for good service. No wonder it is nearly impossible to hire well-trained technicians. Low wages and abuse by the public are no incentive. With his article Mr. Matsinger does more harm than good to our industry.

Let's face the truth: A customer sets a midget on the counter with the words "Fix it!". You find the usual leaked-out A batteries (the 1R5 blew out last fall; the set was stored away during the winter, batteries and all). You test the set, scrape off all the corrosion (if it hasn't gotten into the tuning capacitor yet), and find only minor damage. So you stick in a new 1R5 and a set of batteries.

This takes you or your technician about 15 minutes. Figuring the cost, we have:

	Our cost	Customer's cost
¼ hour at \$1.60	.40	(at \$3) .75
1—1R5 Tube	1.05	2.10
1—67½-volt B battery	1.75	2.50
2—1½-volt A batteries	.16	.25
Ohio State tax	—	.17
	3.36	5.77

In spite of this being a very minor job our cost is \$3.36. I could give hundreds of examples. Mr. Matsinger is either a philanthropist, or a shrewd businessman waiting for everyone to go broke with his suggestions and then grab all the business for himself. I do business to make money, and where there is no profit there is no business.

PAUL BOLLER

Springfield, Ohio

(It is unlikely that Mr. Matsinger included battery replacements in his flat rate for repairing midget receivers. If you leave the batteries out of account, Mr. Boller's estimate and Mr. Matsinger's are not too far apart.—Editor)

SIDELINE SERVICING

Dear Editor:

The letter by William Bacon in the July issue of RADIO-ELECTRONICS hits the nail on the head. The phonies and the failures of the radio and TV repair business have no one to blame but themselves.

This is a land of equal opportunity. If a person can earn an extra honest dollar, more power to him. There is no reason whatsoever to accuse the man who is making it in the radio-television repair field.

A. A. LEWIS

Brooklyn, N. Y.

**'SCOPES ARE
"GOLD MINES"**

... when you know how
to use them fully on all
types of service jobs

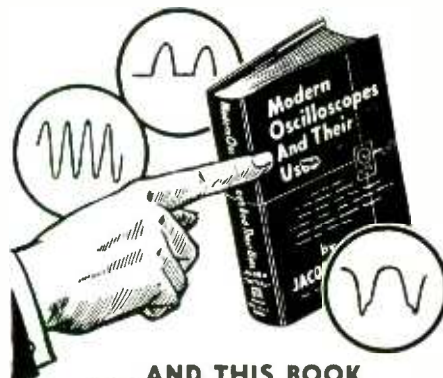

... AND THIS BOOK
MAKES IT EASY TO LEARN
ALL ABOUT THEM!

No question about it! The cathode ray oscilloscope is the handiest, most useful instrument in radio-TV servicing today. Servicemen who master it get the best jobs—make the most money—work lots faster—and are headed for even bigger things in the future!

**MODERN OSCILLOSCOPES
AND THEIR USES**

By Jacob H. Ruiter, Jr.
of Allen B. DuMont Laboratories, Inc.
326 pages. 370 illustrations. \$6.00

- ✓ **When, where, why and exactly how to use them**
- ✓ **How to interpret patterns**
- ✓ **How to handle tough jobs easier and faster**

Now the oscilloscope won't "stump" you—not when you have the clear explanations given by this famous book! It contains no involved mathematics—no puzzling and complicated discussions. Instead, it goes right to work explaining oscilloscopes fully and showing you exactly how to use them in lab work and on AM, FM and TV service work—from locating troubles to handling tough realignment jobs. Each operation is carefully explained including determining where and how to use the 'scope; making connections, adjusting circuit components, setting the controls and analyzing patterns fast and accurately. 370 illustrations including dozens of pattern photos make things doubly clear.

No other type of specific service method training can mean so much to you in terms of efficiency and greater earning power! Send for it today. See for yourself how this book can help you—before you buy!

READ IT 10 DAYS . . . at our risk!

Dept. RE-92 RINEHART BOOKS, Inc.,
Technical Division,
232 Madison Ave., New York 16, N. Y.

Send MODERN OSCILLOSCOPES AND THEIR USES for 10-DAY EXAMINATION. If I decide to keep the book, I will then remit \$6.00 plus a few cents postage in full payment. If not, I will return book postpaid and owe you nothing.

Name _____

Address _____

City, Zone, State _____

Employer's Name & Address _____

OUTSIDE U.S.A.—Price \$6.50 cash only. Money back in 10 days if book is returned.

MONEY-SAVER KITS!

No. 1—Basic 1 tube training kit. Simple to construct complete with all parts one tube and headset diagrams and instructions included. Use 1-354 tube and a 67½ volt Battery. Price \$3.95—less Battery.

Kit No. 2—2 tube Amplifier Kit complete with 50L6, 35Z5, and 4" PM to convert Kit No. 1 to a 3 tube set for loudspeaker operation. \$4.95

Kit No. 3—A low-priced 6 TUBE KIT designed for high sensitivity, excellent selectivity and good tone quality. Uses 25L6, 25Z6, 6SQ7, 6SA7, 6SK7, 6SK7 in an easily constructed circuit. The 6 tube Kit is shipped with all parts, including punched chassis, resistors, condensers, coil, sockets, PM Speaker, hardware, etc.

And at a closeout price of only **\$6.95** less tubes and cabinet

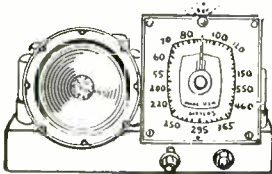

Extra for matched set of six tubes for kit **\$3.25**

5 TUBE AC-DC SUPERHET KIT

Kit No. 4—Five Tube superheterodyne kit, A.C.-D.C. contains all components required to construct this latest design, highly sensitive superheterodyne broadcast receiver complete with black bakelite cabinet (excludes wire and solder) Price \$7.95

Extra for a kit of 5 tubes (12AT6, 12BA6, 12BE6, 35WA, 50CS). Price \$3.25.

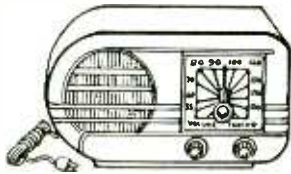

Electronic Code Practice Oscillator & Blinker Kit

AC/DC or Battery Operated!

Kit No. 5—One of the most practical Code Practice Oscillators ever designed, yet one of the simplest to build and operate. Can be used with any number of headphones. Adjustable Pitch Control—Any type of headphone can be used. No warmup time—ready to operate instantly Simple and safe to operate Operates anywhere—with AC or DC power, or from a 90 volt Miniature Battery Learn Blinker Code with flashing light Blinker can be used as signaling device International Morse Code included

Kit each **\$195** Assembled **\$295**

THREE TUBE PHONO AMPLIFIER

An assembled unit ready for installation using tone and volume control and six feet of rubber cord **\$2.95**

(Not including Tubes)
With Complete Set of Tubes\$3.95

PHONO OSCILLATOR

Wireless phono oscillator transmits recording for crystal pick-ups or voice from carbon mike through radio without wires. Can also be used as an intercomm by using P.M. speaker as mike. Price (excluding tubes) **\$2.95**

With Complete Set of Tubes\$3.95

Satisfaction guaranteed on all merchandise All prices subject to change without notice.

Write for FREE Catalog.

RADIO DEALERS SUPPLY CO.

154 Greenwich St. New York 6, N. Y.

DESIGN AND CONSTRUCTION OF A WHEATSTONE BRIDGE, Published by Technological Developments, 475 Fifth Avenue, N. Y. 17, N. Y. 8½x5½ inches. Ten pages of text (unnumbered). Price \$1.00.

This booklet describes the theory and construction of a simplified Wheatstone resistance bridge with a minimum number of parts. The requirements for maximum accuracy (2%) are emphasized and explained with the aid of simple algebra. Step-by-step procedures are given for calibrating the all-important ratio arms. Recommended layouts, operating instructions, and methods of using the bridge with an a.c. source for capacitance and inductance measurements are included. The English text (which looks like a translation) could be improved, but the schematics and tables should make the subject perfectly understandable to the reader with a knowledge of Ohm's Law and elementary algebra.—*MB.*

A SURVEY OF RADIO-FREQUENCY TRANSMISSION LINES AND WAVE GUIDES, by E. S. Winlund. Published by The Radio Club of America, Inc., 11 West 42nd St., New York 18, N. Y. 8½x11 inches. 64 text pages plus a 22-page advertisement section. Price \$1.50.

This book, Volume 28, No. 2 of the Proceedings of the Radio Club of America, is a historical survey of the development of wave guides and transmission lines with pertinent references and technical data from articles published between 1919 and 1936. Also included is a 17-page bibliography of articles on transmission lines, wave guides, and related subjects published through 1951. This survey, unique in its field, contains much information of value to students and communications, electronics-, and antenna engineers, and anyone interested in the subjects covered by the survey.—*RFS.*

AUTOMATIC RECORD CHANGER SERVICE MANUAL, Volume 4 (1951, 1952) CM-4 including latest Multi-Speed Changers, Wire and Tape Recorders. Compiled and published by Howard W. Sams & Co., Inc., 2201 E. 64th St., Indianapolis 5, Ind. 8½x11 inches, pages not numbered. Price \$3.00.

This new book is the result of the publisher's continued practice of making up-to-date servicing data available to the service technician in the most convenient form. It is a compilation of 26 Photofact folders covering 16 record changers, 14 tape recorders, 6 wire recorders, and one combination tape and disc recorder.

Changers and recorders made since 1947 are indexed by manufacturer's name and model number and the original Photofact volume and section (folder) number for each unit described in the book. An 11-page cumulative cross-reference shows the names and model numbers of record changers used in receivers and record players of different trade names and models. The style of presentation is familiar to users of Photofact folders and the publisher's specialized servicing-data books.—*RFS.*

The Book that takes Drudgery out of Mathematics

Only **\$1.** postpaid

SOLVES EVERYDAY PROBLEMS HELPS YOU GET AHEAD IN LIFE

How many times have you lost money because of a mistake in figuring? Do you know how to figure quickly and correctly? Can you figure discounts, interest rates, taxes and all the other calculations you meet up with in your daily life?

Are you having trouble qualifying for Civil Service Exams or Armed Services Promotions, because you're not up on mathematics?

ILLUSTRATED

Here is the book that gives you a good background in mathematics; that takes all the irritation and drudgery out of it. You don't need to be scared of mathematics, because here's the subject explained without frills, without useless computations. Here's the book for men in radio jobs; for business men; technicians and craftsmen, explaining and answering everyday mathematic problems in easy-to-understand words and illustrations.

A BOON TO EVERY RADIOMAN

The Radio Technician will find information on the following: Ohm's Law—Resistance—Reactance—Capacities—Inductances.

The valuable tables are multiplication and division table. Squares; Square Roots; Cubes and Cubic Roots Tables. Areas of Circles Table. Common Fractions reduced to Decimal Table. Factors and Prime Numbers Table. Table of Multiples.

Yes, it's the key to a simple understanding of mathematics. It's a real home-study course in mathematics for the man who's alert to its importance in the world today.

ELEMENTARY MATHEMATICS

• EASY — SIMPLIFIED — PRACTICAL •

CONTENTS OF BOOK

- CHAPTER I. Arithmetic—Addition—Subtraction—Multiplication—Division.
- CHAPTER II. Factoring and Cancellation—Fractions—Decimals—Percentage—Ratio—Proportion.
- CHAPTER III. The Metric System.
- CHAPTER IV. How to Measure Surfaces and Capacity (Geometry).
- CHAPTER V. Powers and Involution—Roots and Evolution.
- CHAPTER VI. Mathematics for the Manual and Technical Craftsman—Thermometer conversions—Graphs or Curve Plotting—Logarithms—Use of the Slide Rule.
- CHAPTER VII. Special Mathematics for the Radio Technician.
- CHAPTER VIII. Commercial Calculations—Interests—Discounts—Short Cut Arithmetic.
- CHAPTER IX. Weights and Measures—Useful Tables.

ONLY **\$1.** POSTPAID

STAMPS, CASH OR MONEY ORDER ACCEPTED

Send Today for Your Copy of This Indispensable Book. It Can Be Carried Readily in Your Pocket. (Size 8 x 9 in.)

TECHNIFAX,

100 East Ohio St. Chicago 11, Ill.

Enclosed find \$1.00 for which send me ELEMENTARY MATHEMATICS prepaid.

Name _____

Address _____

City & State _____

RE-9-52

for dependable sound,
INDUSTRY relies on
ATLAS



DR Double-Reentrant Projectors



Paging & Talk-Back Speakers



ALNICO-V-PLUS Driver Units



Dual Speakers

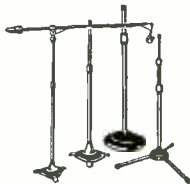

FULL-GRIP, VELVET-ACTION Mike Stands

DEPENDABLE QUALITY:

The latest electro-acoustic research and engineering—over 20 years of manufacturing know-how—are behind every ATLAS product.

DEPENDABLE SERVICE:

Coast-to-coast and around the world today—in every Industrial, Marine, Railroad, Military, Educational, Civic, U.S. and Foreign Government application—under every kind of climate and noise condition—ATLAS sound equipment is famous for highest efficiency and durability. That's the proof of ATLAS performance dependability.

DEPENDABLE DELIVERY:

Yes, ATLAS gives our Government highest priority. And yes, we too feel the pinch of material shortages. But our customers will continue to get our usual dependable delivery—because we believe in equitable and dependable distribution to all ATLAS users.

DEPENDABLE PROFITS:

Completeness of line, excellence of product, dependable delivery, right prices—that's the ATLAS combination that means high, steady Industrial Sound profits for You!

JUDGE for yourself. COMPARE ATLAS at your local Jobber today. See why ATLAS is the preferred line for utmost dependability. Write NOW for FREE latest Catalog 551.

ATLAS SOUND CORP.
1443-39th Street, Brooklyn 18, N. Y.
In Canada: Atlas Radio Corp., Ltd., Toronto, Ont.

RADIO ANTENNA ENGINEERING, by Edmund A. Laport. Published by McGraw-Hill Book Co., Inc., 330 West 42nd St., New York 36, N. Y. 6 x 9 inches, 563 pages. Price \$9.00.

This book by the Chief Engineer of RCA's International Division is written particularly for the non-specialist. Practical information, charts, tables, graphs and photos tell the story of antennas. Formulas and higher mathematics are relegated to relatively minor roles.

The design and construction of antennas are described according to frequency. The first chapter covers frequencies up to 500 kc. We find here information relating to ground-wave propagation, high potentials, top loading. The next chapter is about medium frequencies, including the broadcast band. Topics include optimum radiation angle, directivity, tower design, lighting systems, feed methods. The chapter on h.f. (5-30 mc) covers dipoles, V's, rhombics, long wires and directional arrays. Graphs and patterns show how to choose optimum frequency as well as the antenna dimensions and site.

The remaining chapters describe r.f. transmission lines, coupling networks, graphical synthesis of networks and logarithmic potential theory.

TELEVISION PRINCIPLES AND PRACTICE, by F. J. Camm. Published by George Newnes Limited, Tower House, Southampton St., London WC2, England. 5½ x 8½ inches, 215 pages. Price 25 shillings.

Here is an interesting and practical book on British TV transmission and reception by a leading British technical writer and editor. Television cameras, stereoscopic and color TV, time bases, projection systems, aerials, servicing, and interference are among the chapter headings. Topics include interlacing, synchronizing, timing circuits, pulses, power supplies, interference problems, and repair suggestions. The book ends with a 46-page list of TV terms and a survey of the general plan for British TV broadcasting.

Readers who know radio but have only limited experience with TV will get most benefit from this volume.

British, continental European, and American TV standards differ in many respects. Lines per field, frames per second, carrier frequency bands, polarity of transmission, wave polarization, power-line frequency, even circuits and nomenclature differ. The non-British reader must keep these differences in mind in using this text as a reference source.—IQ

ELECTRONIC ANALOG COMPUTERS, by Granino A. and Theresa M. Korn. Published by McGraw-Hill Book Company, 330 West 42nd St., New York, N.Y. 6 x 9 inches, 378 pages. Price \$7.00.

These authors have prepared a complete description of a subject they know well. The design and operation of analog computers are described clearly and in detail. Starting from elementary electronic principles, the book shows how computers are constructed, tested,

For better, quicker servicing

USE Mandl's Television Servicing

Here are detailed, illustrated instructions for locating and correcting EVERY flaw or failure that may occur in each stage of today's TV receivers. You'll learn simple signal tracing procedures; trade tricks in diagnosing troubles in minimum time; the essentials of successful VHF and UHF servicing; how to trouble-shoot A.G.C. and all other circuits, including the latest improvements. A complete master trouble index enables you to QUICKLY find the cause of and procedures for correcting any trouble, including those hard-to-find troubles. Hundreds of diagrams, original photographs of flaws as they appear on the TV screen, oscilloscope patterns and other illustrations further aid you in locating trouble, testing, and making adjustments.

Noll's Television for Radiomen

Very clear, thorough, non-mathematical explanations of the function and operating principles of every element and circuit in TV reception; how the receiver is constructed; basic principles of transmission; and the techniques of installing, adjusting, and aligning today's receivers, with full instruction on test equipment and its use. Here, in the simplest, clearest terms, is the basic knowledge that is a MUST for good TV work.

AND Noll & Mandl's Television and FM Antenna Guide

Are fringe area reception, ghost reception, interference your problems? This book shows you how to overcome them—how to improve gain; minimize noise on the transmission line; get the MOST out of the antenna system at any location. It tells how to determine the right type of antenna for the site and the best position for it; gives full data on all types of antennas including those for the new UHF and VHF locations, yagi antennas, stacking, boosters, and other fringe area aids.

NOW MORE THAN EVER, YOU'LL NEED THESE EXPERT SERVICE AIDS.

SEE THEM ON APPROVAL

The Macmillan Co., 60 Fifth Ave., N. Y. 11 E

Please send me the books checked below. I will either remit in full or return the books in 10 days.

Mandl's TV Servicing \$5.50 TV & FM Antenna Guide \$6.25

TV for Radiomen \$7.75

Signed

Address

(This offer good only within continental limits of U.S.A.)

***** WE NEED YOUR SURPLUS ELECTRONIC EQUIPMENT *****

WANTED

WE PAY TOP \$\$\$ FOR:

RADIO RECEIVERS TRANSMITTERS
ARC-1
ARC-3
ART-13
CONTROL BOXES INDICATORS
AN CONNECTORS

CLAMPS PLUGS CORDS RELAYS TELEPHONE MATERIALS

WE BUY ANYTHING!!

Write, Wire Today!
Tell us what you have

TALLEN COMPANY, INC.
Dept. RE, 159 Carlton Ave.
Brooklyn 5, New York

"TAB" That's A Buy!

TELEVISION COMPONENT BUYS
 Horiz Def. output, & Hivolts xfmr SIM RCA 211T5 for 15" -18" picture \$19.98
 Width Control similar RCA 201R4.....39
 HiVoltage Condenser 500MMP 15KV.....65
 HiVoltage Condenser 500MMP 20KV.....75
ION TRAP permanent magnet type.....79
 RG59U Cable per ft. .08; 100 ft. \$7.98; 1M ft. \$50.30
 copper twinax 100 ft. \$4.80; 1M ft. \$12.98
 TV Conical Antenna sturdy const. 72, 150, 300 or 495
 match, incl. 8 elements & 100 ft. of twinex, cross
 bar & hardware.....6.95
 Double Stack Conical elements, hd ware cross bar,
 100 ft. all copper twinex.....11.95
 Write for TV tube listing, special low prices

ONE YEAR GTD TV PICTURE TUBES
 10 inch Round \$14.95
 12 inch Round 20.95
 14 inch Rectangular 22.95
 16 inch Round 23.85
 18 inch Rectangular 24.85
 20 inch Round 28.50
 22 inch Rectangular 29.95
 24 inch Rectangular 30.45
 24 inch Metal 67.00
 Your old picture tube is worth money. Write for trade-in allowance toward RMA coded and dated tubes with one year guarantee. Ship your defective picture tubes prepaid only. When ordering metal tube, defective metal tube is required.



"TABS" TUBE SPECIALS
BROKEN KEYS—ELECTRICALLY PERFECT
 1B3GT, 6H6, 6K6GT, 6N7GT, 12SN7GT,
 each 50¢; 5 for \$2.00
 6BG6G, 6BQ6GT, 12SG7, 19B6G, 6L6GA, 6L6G,
 each 79¢; 3 for \$2.00

PHOTOFASH PWR SUPPLY KIT
 1800 at 35 MA, using doubler circuit. Transformer, rectifiers, sockets & resistors & diodes.
 Complete with sunflash tube V-4X4/X400 Rated 200
 watt sec. \$31.98

PHOTOFASH CAPACITORS
 2x.36 MFD, total 72 MFD per unit, 30 units 21.0
 MFD/1800 VDC, 35 MA, 5.95
 30 units 21.0MFD/3000VDC/64.8 watt sec. \$7.95
SAVE ON REPLACEMENTS. WRITE FOR DETAILS
 15MFD 330VAC 1500VDC Intermittent.....\$2.98
 25MFD 330VAC 500VDC Intermittent.....6.49
 18MFD 600VAC 2800VDC Intermittent.....6.95
 10MFD 600VAC 3000VDC Intermittent.....7.95
WRITE FOR SUNFLASH TUBE OPERATING DATA & CIRCUIT SUGGESTIONS.

TAB "SUN-FLASH" LAMPS
 No. Replaces Max. W-sec. Price
 U10 Ge FT114 100 \$ 8.49
 No. 1 AMGLO 7804X 100 9.98
 23ST GE FT 203 200 20.98
 3VGT GE FT 403 500 15.98
 VA SVLV 4330 200 9.98
 23MT FT 210 200 10.98
 22ST FT 110 200 10.98
 353GTQ FT 503 500 54.98
 Write for Complete "THRIFTFLITE" Data Booster-packs, Ext. Hlvs. Units for focal plane shutters & accessories. WE BUY, SELL & SWAP.

SELENIUM POWER SUPPLY
 0 to 12VDC/2 Amp. Variable DC supply. Unused and completely built-in. 115V/60 cyc. Usable IAB supply filament, I.C. battery charging, model railroad, includes voltage or speed control and center off reversing switch for two "HO" locomotives.
"TAB" Special \$10.95 2 for \$20.00

FULL WAVE BRIDGE SELENIUM RECTIFIERS

Current (Cont)	18/14 volts	26/18 volts	36/28 volts	130/100 volts
2 amps	2.20	3.60	3.60	2.5A \$13
4 amps	3.75	6.75	6.75	
6 amps	4.95	7.95	7.95	27.00
10 amps	6.50	12.00	12.00	50.00
12 amps	6.50	16.00	16.00	52.50
20 amps	13.25	16.20	24.00	90.00
24 amps	16.00	21.00	31.00	98.00
30 amps	18.50	24.30	36.00	
36 amps	25.50	45.00		

CT Rectifiers 100 amp 10-0-10V \$44.95
 80 Amp 18-0-18V \$29.95 80 Amp 36-0-36V \$53.95
 Full Wave Selenium & Transformers with Ageing Taps, in form. All 115V/60cy inputs.
 up to 16 VDC at 12 amps.....\$23.98
 up to 28VDC at 12 amps.....31.98
 up to 28VDC at 48 amps.....149.50
 up to *20VDC at 6 amps.....12.98
 *This 0 amp supply has no acting taps.
 We specialize in power supplies to your specifications

RECTIFIER TRANSFORMERS
 18-19-2-20-4-21.4 volts/12 amp 2Kvins. \$14.98
 31-32-34-36 volts/12 amp 2Kvins. 16.49
 18-12-9-CT-8-12-18 volts/4 amp 8.75
 18-12-9-CT-8-12-18 volts/12 amp 34.75
 36VCT-24V-18V-24 amp 35.75

INFRARED SNOOPERSCOPE
 Image-Converter Tube HiSensitivity simplified design 2" dia. Willemite screen—2 1/2" Hlvs. Resolution up to 350 lines/in. Complete data & tube, each. \$4.98; 2 for \$9.49

SNOOPERSCOPE PWR SUPP KIT
 Inpt 115V/60cy outpt 1800V DC/35mA, using voltage d'blr circuit. Incl trans, rectifiers, sockets, resistors, condns, and wiring diagram. \$6.98

TRANSFORMERS 115 V 60 CYC INPUT V & CR Pwr Xfmr for 7" to 20"
 Tubes, Hl VOLTAGE TO 200V (incl. 100V rpldr ckt). ALL Tubes, Pl & FIL wdgs dvrng; 300 VDC/275MA Full-Wave. W-4V/10.3A, 5.4V/8A, 2.5V/3A Hyper-sil Co. G.I. impreg. 2 for \$12.49
 2500V for CRT 6.3V/6A 2.5V/1.75A Hvlvs. \$7.98
 1320V & 375VCT/10MA, 5V/3A, 2.5V/3.25A, 6.3V/2.75A Hlvs Hvlvs Thornton \$9.98
 1000VCT/45MA, 75VCT/80MA & 360Vct/55MA, 3x5V/3A, 6.3Vct/1A, 6.3Vct/3A Cd Hvlvs can be used 2X Rating. Raytheon Hvlvs core \$4.98
 900V/35MA, 2x2.5V/2A, Xclent 1800V d'blr tws 2x2 FIL. wdgs, Hlvs, Hvlvs. \$3.49
 750VCT/300MA, 8.3V/5A, 4V/4A \$5.95
 600VCT/100MA, Tapped 350VCT, 6.3V/3A, 2.5V/3A, Isolation Wdgr 115V/450MA \$3.25
 700VCT/120MA, 2x6.3V/3A, 6.3V/1A \$3.98
 570VCT/80MA, 12V/3A, Hlvs \$4.49
 400VCT/60MA, 6.3V/4A Hlvs \$2.98
 520VCT/90MA, 6.3V/1.9A, w/inpts 6.12-24 115 Vdc & 115 230VAC \$3.24
 Write for "TABOGRAM" Bargain Sheet

"TAB" Prices Subject to Change
 Dept. 9RE 6 Church Street
 New York 6, N. Y. U. S. A.
 Cor. Church & Liberty Sts.
 Room 200. Phone Rector 2-6245

ADVERTISING INDEX

Adelman, Nat	90
Allied Radio Corporation	112
American Electrical Heater Co.	94
American Phenolic Corp.	100
Amplifier Corporation of America	99
Arky Radio Kits, Inc.	91
Asafic Corporation	29
Atlas Sound Corp.	129
Barry Electronics Corp.	130
Belden Manufacturing Co.	8
Bell Telephone Labs.	6
Bendix Radio	117
Blonder-Tongue Labs.	109
Brook Electronics, Inc.	90
Brooks Radio & Television Corp.	103, 104, 105
Candler System Co.	124
Capitol Radio Engineering Institute	5
Central—Div. of Globe Union	76, 77
Channel Master Corp.	12, 13
Cleveland Institute of Radio Electronics	9
Communications Equipment Company	111
Concord Radio	84
Cornell-Dubilier Electric Corp.	74
Coyne Electrical & TV Radio School	108, 115
Crest Laboratories	86
Crown Television	118
Davis Electronics	102
DeForest's Training, Inc.	7
DuMont Labs., Inc. Allen B.	Inside Front Cover
Electro-Voice, Inc.	89
Electronic Instrument Co., Inc.	26
Electronics Measurements Corp.	72
Feiler Engineering Co.	119, 120, 124
General Electric Co.	18
General Industries Co.	113
General Test Equipment	99
Greylock Electrical Supply Co.	124
Hickock Electrical Instrument Co.	87, 102
Higgins & Shier	93
Hudson Specialties Co.	109
Hughes Aircraft Corp.	132
Hytron Radio & Electronics Corp.	83
Illinois Research Laboratories	120
Indiana Technical College	119
Instructograph Company	90
JFD Manufacturing Company, Inc.	59
Jackson Electrical Instrument Co.	88
Jensen Industries, Inc.	79
Jensen Manufacturing Co.	99
Jersey Specialty Company	122
Jones & Laughlin Steel Corp.	82
Kedman Company	124
Krylon, Inc.	10
LaPointe-Plascomold Corp.	75
Leotone Radio Corp.	86
The Macmillan Company	129
Mally & Co., Inc. P. R.	Inside Back Cover
Mattison Television & Radio Corp.	119
McGraw-Hill Book Co.	131
Merit Coil & Transformer Co.	24
Miles Reproducer Co., Inc.	124
Mossley Electronics	67
Moss Electronic Distributing Co., Inc.	67
National Electronics of Cleveland	114
National Plans Company	93
National Radio Institute	19, 20
National Schools	3
Omrite Manufacturing Co.	70
Opportunity & Supply	122
Oxford Electric Corp.	80
Passantino Printing Co., Inc.	131
Perma-Power Company	78
Philo Corporation	85
Pickering & Company	127
Precision Appliance Co., Inc.	127
Prentice-Hall, Inc.	86, 108
Pres-Probe Co.	131
Progressive Electronics Co.	96
Quam-Nichols Company	110
RCA Institutes, Inc.	17
RCA Victor Division (Radio Corporation of America)	95, Back Cover
Radelco Manufacturing Co.	105
Radiart Corporation	69, 127
Radio City Products Co.	118
Radio Dealers Supply	128
Radio Receptor Co., Inc.	98

New Listing Every Month TUBES

Standard R.M.A. Warranty. We endeavor to give you low, low prices, consistent with quality merchandise and service.

Here is only a partial listing of our large stocks. You may order popular types not listed at approx. same savings. Note Specials in Light-face Type.

OA2	1.10	68Y5-G	1.60	12SK7	.75
OB2	1.10	68Y5-G	1.10	12SL7	.75
OA7	.59	6C4	.49	12SN7GT	.87
1A7GT	.98	6CB6	.45	12SR7-M	.75
1AE4	1.10	6F6-M	.88	25AV5	1.25
1B3GT	.83	6F8-G	.89	25BQ6-GT	.79
1L4	.69	6G6-G	.95	25L6-GT	.65
1N21-B	3.45	6J5GT	.49	25Z6	.75
1N23	1.35	6J6	.59	35B5	.40
1N23-A	2.45	6J7	.75	35C5	.40
1N23-B	3.70	6K6GT	.66	35L6	.69
1N34	.64	6K7-M	.71	35Z5-GT	.55
1N34-A	.75	6L5G	.49	50C5	.50
1N44	1.21	6L6-GA	1.19	50L6-GT	.55
1N45	1.39	6L7	.98	211	.70
1N54	.89	6S7-M	.98	304A-TL	8.00
1U4	.49	6SD7	.79	304-TH	7.75
2B7	.75	6S7G	.88	717-A	.98
2C43	15.95	6S7H	.70	805	2.50
2C21	1.35	6SJ7-GT	.69	807	1.59
2E24	3.00	6S7J-M	.75	811	2.80
2E30	2.19	6SK7-GT	.60	829	9.95
3A4	.59	6SL7-GT	.60	832	4.95
3A6/1299	.50	6SN7-GT	.59	832-A	8.50
3Q4	.49	6T8	.79	837	1.45
3Q5GT/G	.99	6U4-GT	.59	866-A	1.55
3S4	.80	6V6-GT	.60	8E72-A	3.50
5F7	1.95	6X5-GT	.45	1280	.80
5K6	.59	6Y6-G	.95	1613	.75
5X4	.99	7A6	.65	1614	2.25
5Y3GT	.85	7A8	.75	1616	.74
5Z3	.45	7C7	.80	1619	.30
5Z3	.89	7H7	.80	1622(6L6)	1.95
6AB4	.75	12A6	.65	1625	.40
6A67	.98	12C8	.79	1629	.30
6AG5	.98	12H6	.75	1631	1.50
6AH6	.70	12AT7	.75	1632	.70
6AJ5	1.00	12AU7	.95	2050	1.48
6AK5	1.65	12AV6	.55	5516	5.95
6AK6	.90	12BA6	.69	5608-A	3.95
6AL5	.45	12BA7	.90	5654	2.00
6AN5	2.50	12BD6	1.25	5910	1.60
6AT6	2.50	12BE6	.45	8008	.75
6AUG	.45	12SA7	.75	9001	1.35
6AV6	.55	12SF5	.70	9002	.80
6B8	.65	12SG7	.87	9003	1.10
6BC5	.84	12SH7	.95	9004	.39
6BD6	.84	12SJ7	.75	9004	.39
6BE6	.45				

and MANY OTHERS

SELENIUM RECTIFIERS

Full-Wave Bridge Types

Current (Continuous)	18/14 Volts	36/28 Volts	54/42 Volts	130/100 Volts
1 Amp.	\$2.10	\$8.95
2 Amps.	2.20	3.60	6.50	10.50
2 1/2 Amps.	13.00
4 Amps.	3.75	6.75	8.75
5 Amps.	4.95	7.95	12.95	27.00
6 Amps.	5.50	9.00	14.00	36.00
10 Amps.	6.75	12.00	20.00	45.00
12 Amps.	8.50	16.00	25.50	52.50
20 Amps.	13.25	24.00	36.00	90.00
24 Amps.	16.00	31.00	39.50	98.00
30 Amps.	18.50	36.00
36 Amps.	25.50	45.00

New Selenium Rectifier Transformers
 PRI: 115 V., 60 cycles in. 4 Amps. \$ 8.75
 SEC: 9, 12, 18, 24, and 36 } 12 Amps. 16.75
 volts } 24 Amps. 35.75

Made to our specs. for continuous, heavy-duty use
 • 115V. PRI—36V. 50 amp second XFMR \$39.95
 • 115V. PRI—5V. at 190 AMP. SEC \$59.95
 • 115/230 V. 60 cv. PRI. SEC : 1.5. 30.5. 33.5.
 and 36.5V. at 4 AMPS. Herm. Sealed @ \$6.50
 • New Selenium Rectifier Chokes
 4 Amps.—.07 hy.—.06 ohm \$7.95
 12 Amps.—.01 hy.—.1 ohm \$14.95
 24 Amps.—.004 hy.—.025 ohm \$29.95

We can manufacture other Sel. Rec., Sel. Rec. Supplies, XFMRs., & Chokes.
 • In stock—3 New NC-183-D Receivers in sealed cartons, complete with 3 National Speakers. Special Price. Write.

5 lb. spoons of finest rosin-core solder only \$3.75
 • ART-I—DeLux 75 Meter AM Mobile XMTR.—New—Complete Only \$19.95
 • AR-II—Complete Station for 20, 40, 80 Superhet Rcvr.—50 Watts CW w/built in AC Pwr Supply. New—in compact suitcase (orig. cost over \$500). An excellent buy for only \$99.50
 • Weston Meters, 0-100 micro amps, 2 1/4" Diam. (Blank Scale) New Boxed. Very Special \$5.95
 Carter, 6 V. Dynamotors, in original cartons.—590 VDC @ 150 ma. Only 7" x 4" x 3".—Special \$28.00.

BARRY ELECTRONICS CORP
 136 Liberty Street, N.Y. 6, N.Y. Rector 2-2563
 Terms: 25% with order, balance C.O.D.—Send a few cents for postage—All merchandise guaranteed. F.O.B. N.Y.C. *Please, min. order \$2!*

THE DATA YOU MUST HAVE!

"PICTURE TUBES CAN BE SAVED"

Practical and proved methods resulting from thousands of tests on 'defective' pix tubes

SHOWS YOU HOW TO CORRECT FOR LESS THAN \$1.00!

SHORTED ELEMENTS
LO EMISSION
INTERMITTENTS
OPENS
LEAKAGE

SEND **\$1.00** CASH OR MONEY ORDER
In California Add 3%
Tele-Research Labs
P.O. Box 78306
Los Angeles 16
California

AUTOMATIC M-90 AUTO RADIO



• Six Tube Superheterodyne • Three Gang Condenser • Powerful, Long-Distance Reception • Fits All Cars, Easy Installation

• Mounting Brackets Included
• 6 Tube model M90 *\$34.97
• 5 Tube Model A-15 \$28.76
*Above price includes Federal Excise Tax
Approx. shipping weight either radio (11) eleven pounds

MAIL US YOUR ORDERS

All orders filled within 24 hours.
Standard Brand tubes 50% off list

Bill Sutton's Wholesale Electronics
Fifth at Commerce Fort Worth, Texas

PRES-PROBE CONDENSER TESTER



Finds Intermittent
Condensers Instantly

NET
795
Postpaid U.S.A.
Pres-probe's sliding tip with variable resistance prevents condenser heating. Tests with power on. Requires no adjustment. Stops guesswork. Saves time. Convenient probe size (7 1/4" long). Satisfaction guaranteed.

See Your Dist. or Order Direct

PRES-PROBE CO.
4034 N. Sixth St., Milwaukee 12, Wisc.

WANT REPRINTS?

Offset reproductions of any of the fine articles appearing in RADIO-ELECTRONICS supplied! Excellent work, low cost! Orders for reprints accepted in any quantities over 100. Write for an estimate.

PASSANTINO PRINTING CO.
250 West 49th St. New York 19, N. Y.

and applied. An entire chapter is devoted to the important subject of setup procedures. The reader must know something of calculus. Although the computer does the actual work of solving a problem, the operator must first set it up. Often the problem involves differential or integral calculus.

The third chapter shows practical applications. Typical equations are given for problems like flight of aircraft, oscillations, ballistic paths. Block diagrams show how the computer is set for the particular equation to be solved. Following chapters discuss potentiometers, differentiators, integrators, operational amplifiers, function generators, recorders, and other topics. The final chapter is devoted to complete installations. Among instruments described are those by Boeing, Goodyear, Curtiss-Wright, and Reeves.—IQ

SOUND RECORDING AND REPRODUCTION, by J. W. Godfrey and S. W. Amos. Published for Wireless World by Iliffe & Sons, Ltd., Dorset House, Stamford St., London, England. 5 1/2 x 8 1/2 inches, 271 pages. Price \$6.75.

This book was prepared as a source of practical instruction for BBC engineers. It describes principles and equipment for disc, film, and tape. Most of the book covers disc recording, reproduction, and processing. BBC and Presto equipment is illustrated. Cutters, equalizers, playbacks, amplifiers, and frequency characteristics are among the subjects.

Only one chapter (20 pages) is devoted to tape. This hardly seems sufficient, considering the widespread use of tape in modern broadcasting. Principles and equipment are only briefly described. Film is also given a single chapter.

The appendices contain much interesting information for the recordist. Sapphire cutters, induction motors, film scanning, and frequency fluctuation (wow) are analyzed.—IQ

INTRODUCTION TO INDUSTRIAL ELECTRONICS, by R. Ralph Benedict. Published by Prentice-Hall, Inc., New York, N. Y. 5 3/4 x 8 1/2 inches, 436 pages. Price \$7.00.

This book teaches principles and practices of industrial electronics. It covers much ground and is clearly written. The first half of the book covers vacuum and gas tubes and their circuits. It describes the cathode-ray oscilloscope, thyratron, X-ray tube, phototubes, and many other special types. Amplifiers, oscillators, and detectors are discussed. The last half is devoted to practical applications of electronics. There are chapters on controlled rectification, power conversion, high-frequency heating, electronic relays, control, and instrumentation.

The author stresses the use of load lines and tube graphs, the logical method for designing tube circuits. No higher mathematics is needed.

Exercises and references complete each chapter.—IQ

—end—



Special Offer On This Complete RADIO ENGINEERING LIBRARY

New, Up-To-Date Editions of Famous Library Covers Whole Field of Radio Engineering. Places Latest Facts, Standards, Data Practice, and Theory At Your Fingertips

The five big volumes of the new edition of the Radio Engineering Library now include the very latest facts, standards, data, and practice. This Library will help solve hundreds of problems for designers, researchers, engineers, and students in any field based on radio.

Written by leading radio engineers, these books cover circuit phenomena, networks, tube theory, vacuum tubes, amplification, measurements, etc.—give specialized treatment of all fields of practical design and application. They provide you with a complete and dependable encyclopedia of facts.

- 5 Volumes, 3872 Pages, 2770 Illustrations
- Eastman's FUNDAMENTALS OF VACUUM TUBES, 3rd Edition.
- Terman's RADIO ENGINEERING, 3rd Edition.
- Everett's COMMUNICATION ENGINEERING, 2nd Edition.
- Hund's HIGH FREQUENCY MEASUREMENTS, 2nd Edition.
- Henney's RADIO ENGINEERING HANDBOOK, 4th Edition.

SEND NO MONEY

Special Low Price—Easy Terms

On this special offer you get this Library for \$37.50, instead of \$43.50. You save \$6 and may pay on easy terms. Mail coupon below to examine the Library FREE for 10 days. No obligation. These books are recognized as standard works; you are bound to need them. So take advantage of this special money-saving offer. *Mail coupon at once!*

McGraw-Hill Book Co., Dept. RE-9-52
327 West 41st St., New York 18, N. Y.
Send for 10 days' FREE trial, the RADIO ENGINEERING LIBRARY. If not satisfied I will return books. Otherwise I will send \$7.50 plus delivery charges, then; and \$6 a month for 5 months. (Reg. price \$43.50, you save \$6).

Name

Home Address

City & State RE-9-52

We'll Pay Delivery Charges if you enclose \$7.50 first payment WITH coupon. Same return privilege for full refund.

to the **E. E. or PHYSICS GRADUATE**

with experience in

RADAR OR ELECTRONICS

Hughes Research and Development Laboratories, one of the nation's large electronics organizations, is now creating a number of new openings in an important phase of its operation.



Here is what one of these positions offers you:

1. THE COMPANY

Hughes Research and Development Laboratories is located in Southern California. We are presently engaged in the development of advanced radar devices, electronic computers and guided missiles.

2. THE NEW OPENINGS

The positions are for men who will serve as technical advisors to the companies and government agencies purchasing Hughes equipment. Your specific job would be to help insure the successful operation of our equipment in the field.

3. THE TRAINING

Upon joining our organization,

you will work in our Laboratories for several months until you are thoroughly familiar with the equipment you will later help the Services to understand and properly employ.

4. WHERE YOU WORK

After your period of training (at full pay), you may (1) remain with the company Laboratories in Southern California in an instruction or administrative capacity, (2) become the Hughes representative at a company where our equipment is being installed, or (3) be the Hughes representative at a military base in this country—

or overseas (single men only). Compensation is made for traveling and for moving household effects, and married men keep their families with them at all times.

5. YOUR FUTURE

You will gain all-around experience that will increase your value to the company as it further expands in the field of electronics. The next few years are certain to see a large-scale commercial employment of electronic systems—and your training in the most advanced electronic techniques now will qualify you for even more important positions then.

HOW TO APPLY

If you are under thirty-five years of age, and if you have an E. E. or Physics degree, with some experience in radar or electronics,

write to:

HUGHES

RESEARCH AND DEVELOPMENT LABORATORIES
Engineering Personnel Department
CULVER CITY, LOS ANGELES COUNTY, CALIFORNIA



Assurance is required that relocation of the applicant will not cause disruption of an urgent military project.

NOT IN STOCK

WON'T FIT

DOESN'T MATCH

SLOW DELIVERY



Got "Dual Control headaches?"

MALLORY MIDGETROLS® will cure them!

Why wait for delivery—why scour distributors' stocks for special controls? You can replace *any* dual control in only a few minutes, by assembling the *exact* combination you need with Mallory Midgetrol Companion Units.



Factory Equipment



Mallory Replacement

Here's how easy it is to get an *exact replacement* for the original control. You just combine the Mallory factory-assembled front and rear control sections... add the easily attached switch... insert the shaft tip. The job takes less than five minutes. No soldering, no special tools.

Quick—sure—economical. Here's the way to get the control you need, with these features:

- **Exact match**, electrically and mechanically, for original components.
- **Highest quality**—quiet, drift-free resistance elements, accurate tapers, wobble-free, two-point suspension.

Best of all, you won't have to carry big inventories. A small selection of standard sections will equip you to service all the popular radio and TV sets. Your Mallory distributor has a complete stock of control sections, switches and hardware ready for immediate delivery. See him today!

P. R. MALLORY & CO. INC.
MALLORY
 CAPACITORS... CONTROLS... VIBRATORS...
 SWITCHES... RESISTORS... RECTIFIERS...
 VIBRAPACK® POWER SUPPLIES... FILTERS
*Reg. U.S. Pat. Off.
APPROVED PRECISION PRODUCTS
P. R. MALLORY & CO., Inc., INDIANAPOLIS 6, INDIANA

*Make Sure...
Make it Mallory*

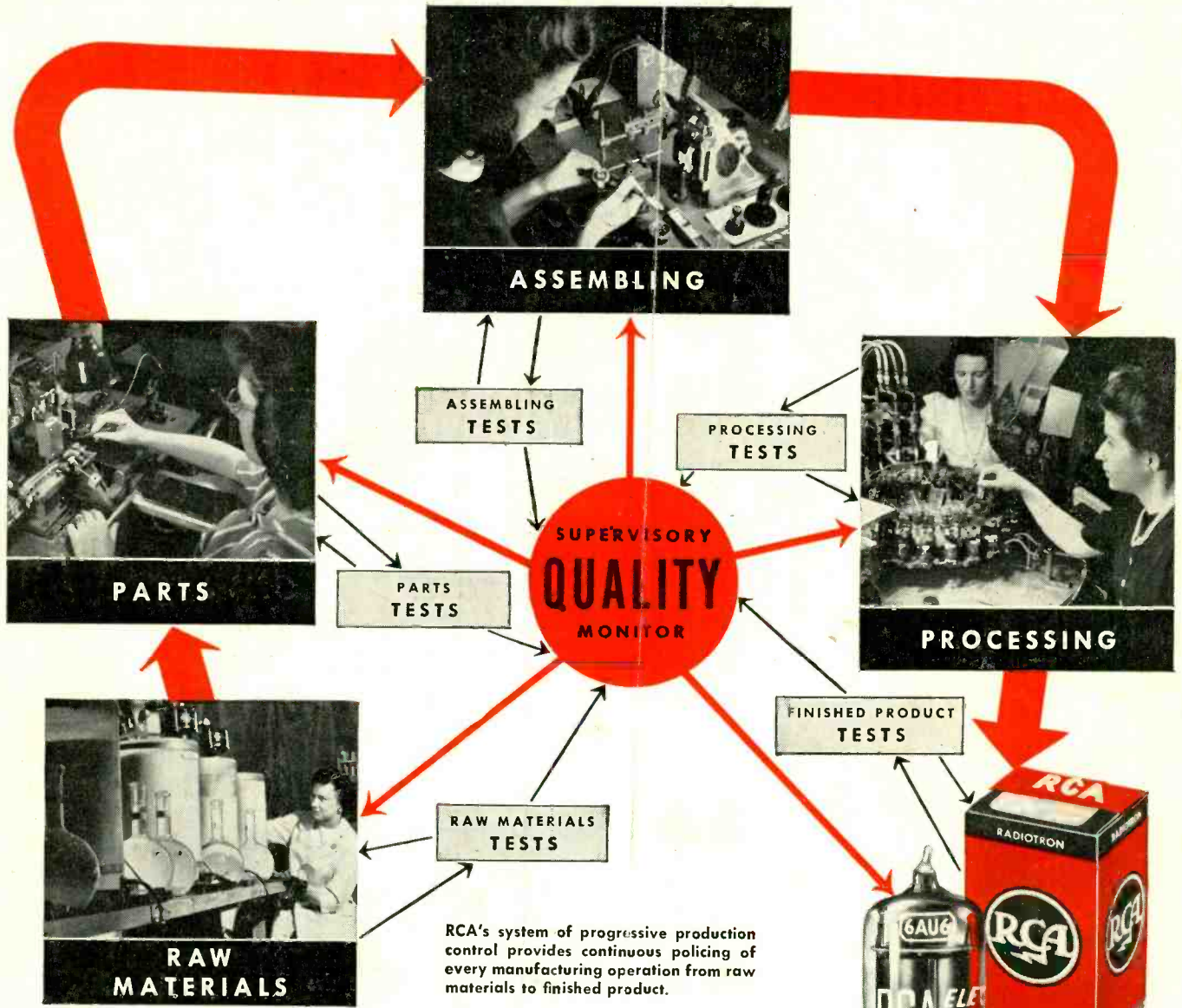

Quality control by feedback ...the secret of RCA tube performance

FOR MANY YEARS, RCA has employed a system, which might be called "feedback" control, in the manufacture of RCA Tubes. This system is recognized by industry as a most effective method for achieving superior product quality. Here's how it works . . .

Test positions are set up at every important production point . . . from raw materials to the finished tube. Tests are made periodically at each point, and the data transmitted to a central supervisory

group of quality-control engineers. This group immediately spots any deviations from prescribed quality standards, and corrects them on the production line almost before they happen! Result . . . *inferior tubes never reach your shop.*

RCA's constant vigilance at all stages of manufacture is your assurance that only uniform, top-quality RCA Tubes leave the factory. In this way, RCA closely guards its own reputation . . . *and yours as well.*



With RCA Kinescopes, as well as with RCA Receiving Tubes, **TOP-QUALITY CONTROL** makes the difference.



RADIO CORPORATION of AMERICA
 ELECTRON TUBES

HARRISON, N. J.

Tmk. ®

ADV Plans, LLC

Copyright Notice:

The entire contents of this CD/DVD are copyright 2014 by ADV Plans, LLC. All Rights Reserved.

Reproduction or distribution of this disk, either free or for a fee is strictly prohibited. We actively monitor and remove listings on eBay thru Vero.

You are free to copy or use individual images in your own projects, magazines, brochures or other school projects.

Only the sellers listed here are authorized distributors of this collection:
www.theclassicarchives.com/authorizedsuppliers

Please view our other products at
www.theclassicarchives.com,
or our ebay stores:

[TheClassicArchives](#)
[ADVPlans](#)
[SuperShedPlans](#)

